

Copyright (C) Nokia Corporation. All rights reserved.
 THIS DRAWING IS PROTECTED BY COPYRIGHT AS AN UNPUBLISHED WORK.
 UNAUTHORIZED REPRODUCTION OF THIS DRAWING IS NOT PERMITTED.
 THIS DRAWING CONTAINS PROPRIETARY AND CONFIDENTIAL INFORMATION.
 This document is property of Nokia Corporation

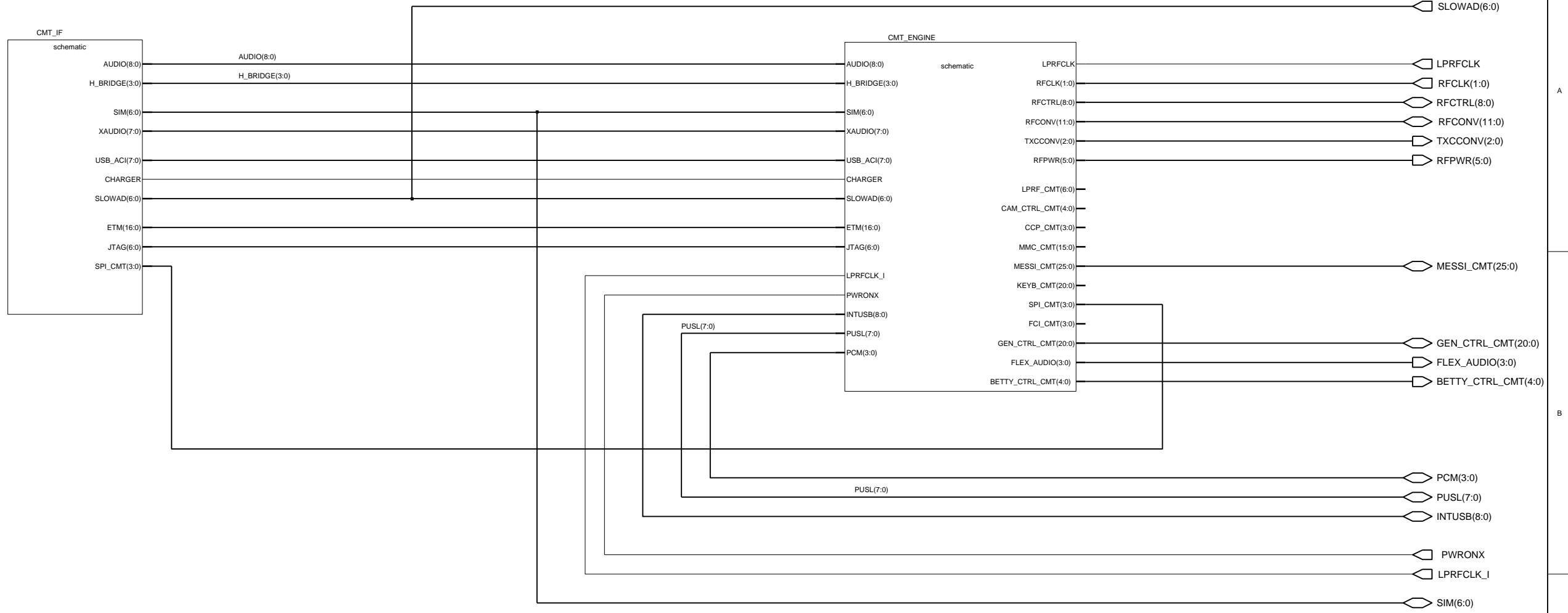

| | | | |
|-------|--|-------|------------------------|
| Name | BB Top Level | Appr | dd-mmm-yy |
| Assoc | Vilbet | Build | B 1.0 |
| | | Des. | ILJARVIN 18-Aug-03 |
| | | Dr. | TKOIVUSA 03-Jan-07 |
| File | /nokia/sa_nmp/groups/p3047/rm-208/1yb/1yb_07/SYS | | Sheet 03 of yy 0 (01) |
| Proj | WG3.2 | Draw. | Print Yes v. 02 Edit 2 |



ANT

Copyright (C) Nokia Corporation. All rights reserved.
 THIS DRAWING IS PROTECTED BY COPYRIGHT AS AN UNPUBLISHED WORK.
 UNAUTHORIZED REPRODUCTION OF THIS DRAWING IS NOT PERMITTED.
 THIS DRAWING CONTAINS PROPRIETARY AND CONFIDENTIAL INFORMATION.
 This document is property of Nokia Corporation



| | | | |
|-------|---|-------|--------------------|
| Name | BB Top Level | Appr | dd-mmm-yy |
| Assoc | Villie | Des. | KAYRA 14-Jan-03 |
| File | /nokia/sa_nmp/groups/p3047/rm-208/1yb/1yb_07/cellular | Dr. | TKOIVUSA 03-Jan-07 |
| Proj | CBB5X | Sheet | xx of yy 0 (01) |
| | | Print | Yes v. 0 Edit 2 |

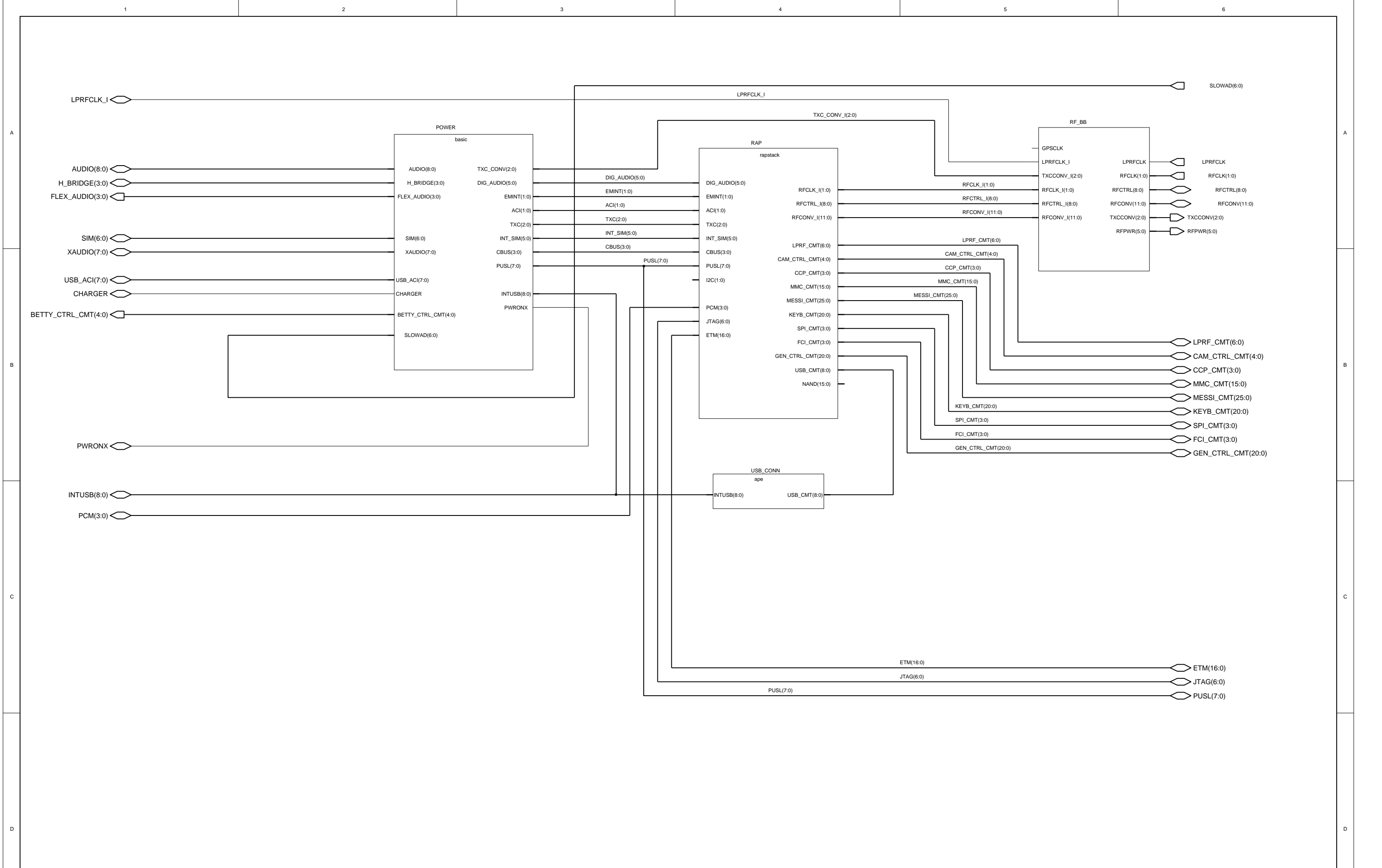

Copyright (C) Nokia Corporation. All rights reserved.
 THIS DRAWING IS PROTECTED BY COPYRIGHT AS AN UNPUBLISHED WORK.
 UNAUTHORIZED REPRODUCTION OF THIS DRAWING IS NOT PERMITTED.
 THIS DRAWING CONTAINS PROPRIETARY AND CONFIDENTIAL INFORMATION.
 This document is property of Nokia Corporation



| | | | |
|-------|--|-------|-------------------------|
| Name | CMT_Engine Top level | Appr | dd-mmm-yy |
| Assoc | Engine Release Database | Des. | ArKa 27-May-03 |
| | | Dr. | TKOIVUSA 03-Jan-07 |
| File | /nokia/sa_nmp/groups/p3047/rm-208/1yb/1yb_07/cellular/cmt_engine | | Sheet xx of yy 0 (01) |
| Proj | Cement | Draw. | Print Yes v. 0.0 Edit 2 |

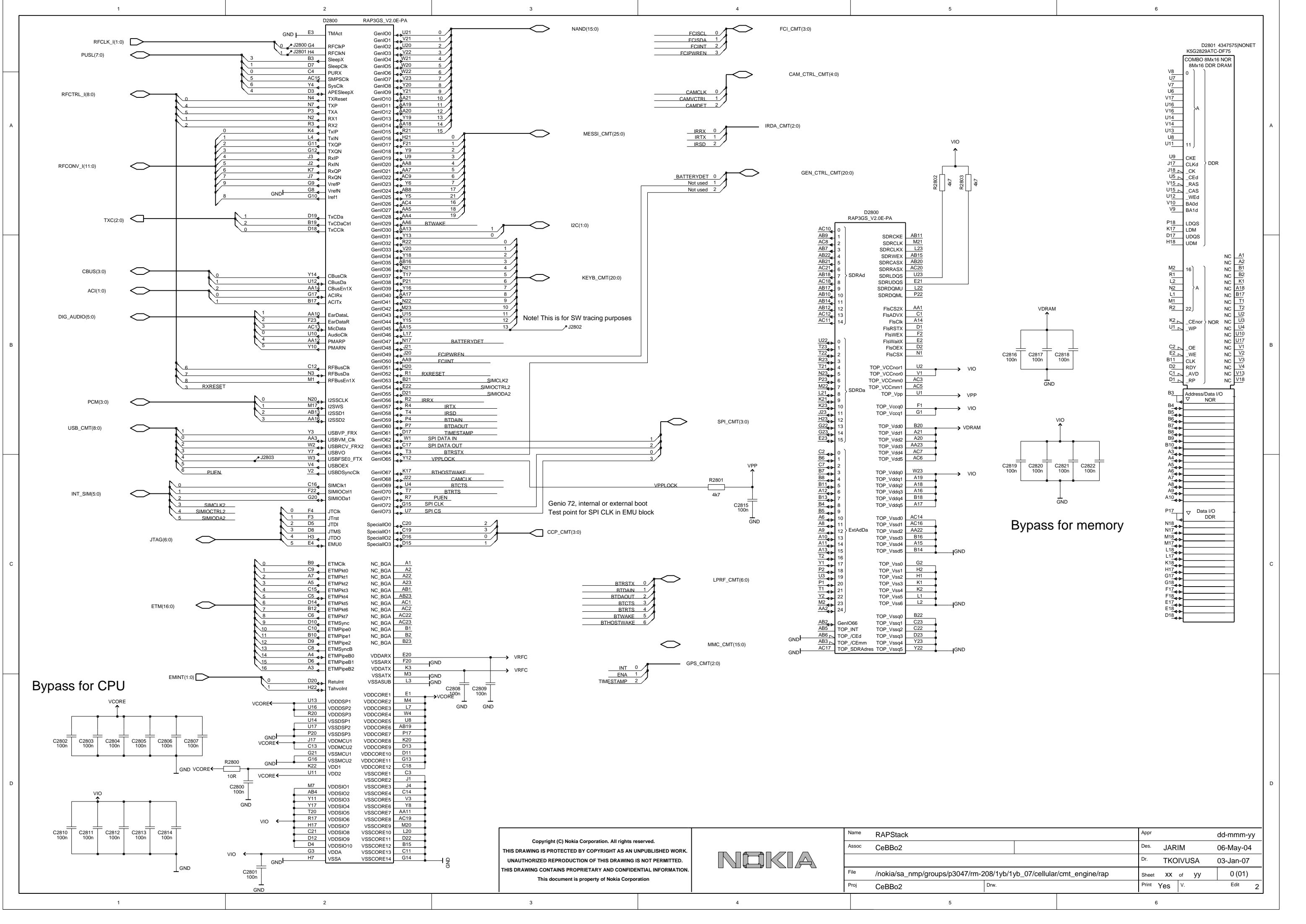

Bypass for CPU

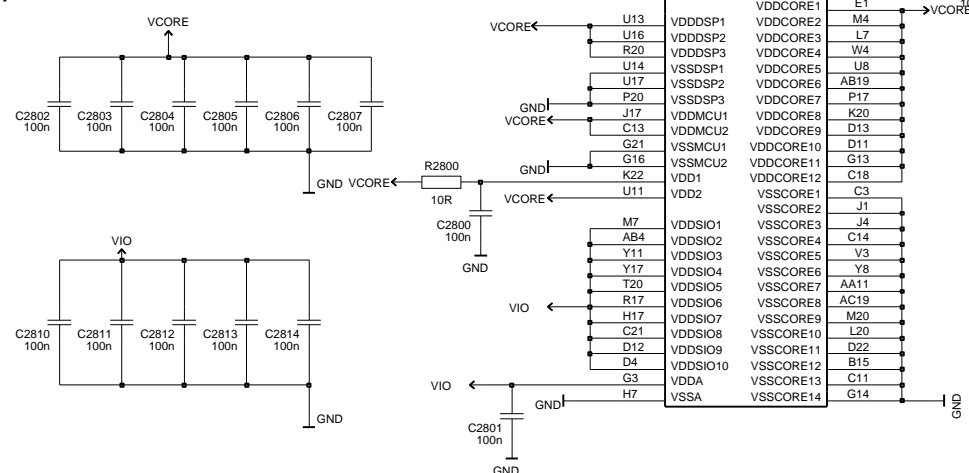

Bypass for memory

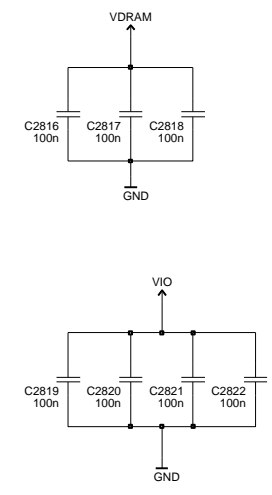

Copyright (C) Nokia Corporation. All rights reserved.
 THIS DRAWING IS PROTECTED BY COPYRIGHT AS AN UNPUBLISHED WORK.
 UNAUTHORIZED REPRODUCTION OF THIS DRAWING IS NOT PERMITTED.
 THIS DRAWING CONTAINS PROPRIETARY AND CONFIDENTIAL INFORMATION.
 This document is property of Nokia Corporation



| | | | |
|-------|--|-------|--------------------|
| Name | RAPStack | Appr | dd-mmm-yy |
| Assoc | CeBBo2 | Des. | JARIM 06-May-04 |
| File | /nokia/sa_nmp/groups/p3047/rm-208/1yb/1yb_07/cellular/cmt_engine/rap | Dr. | TKOIVUSA 03-Jan-07 |
| Proj | CeBBo2 | Sheet | xx of yy 0 (01) |
| | | Print | Yes v. Edit 2 |

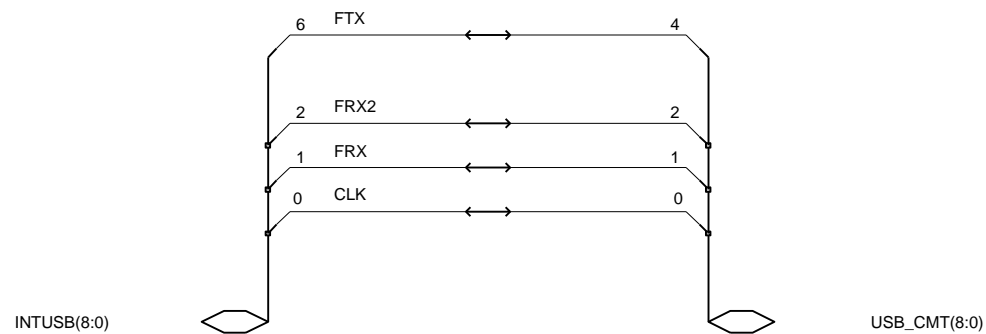

Copyright (C) Nokia Corporation. All rights reserved.
 THIS DRAWING IS PROTECTED BY COPYRIGHT AS AN UNPUBLISHED WORK.
 UNAUTHORIZED REPRODUCTION OF THIS DRAWING IS NOT PERMITTED.
 THIS DRAWING CONTAINS PROPRIETARY AND CONFIDENTIAL INFORMATION.
 This document is property of Nokia Corporation



| | | | |
|-------|---|-------|-------------------------|
| Name | USB Connections with APE | Appr | dd-mmm-yy |
| Assoc | Engine Release Database | Des. | KatjaKnu 04-Jun-03 |
| | | Dr. | TKOIVUSA 03-Jan-07 |
| File | /nokia/sa_nmp/groups/p3047/rm-208/1yb/1yb_07/cellular/cmt_engine/usb_conn | Sheet | XX of yy 0 (01) |
| Proj | Cement | Drw. | Print Yes V. 0.0 Edit 2 |

CBB5X

TOP SHEET

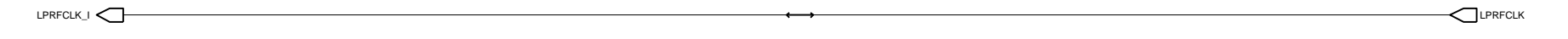
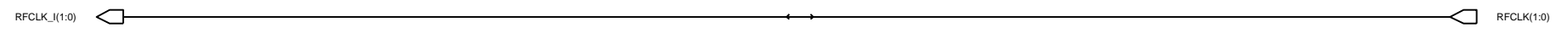

GPSCLK

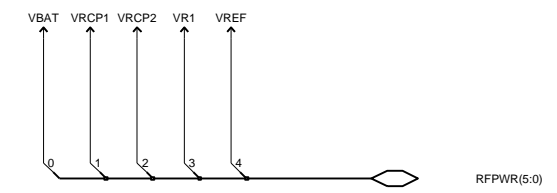
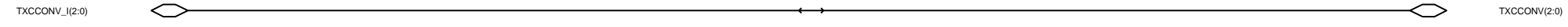
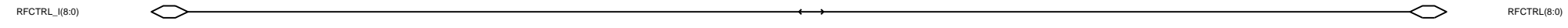
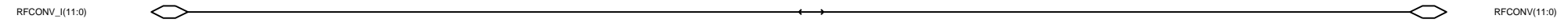

Copyright (C) Nokia Corporation. All rights reserved.
 THIS DRAWING IS PROTECTED BY COPYRIGHT AS AN UNPUBLISHED WORK.
 UNAUTHORIZED REPRODUCTION OF THIS DRAWING IS NOT PERMITTED.
 THIS DRAWING CONTAINS PROPRIETARY AND CONFIDENTIAL INFORMATION.
 This document is property of Nokia Corporation



| | | | |
|-------|--|----------------|--------------------|
| Name | RF IF | Appr | dd-mmm-yy |
| Assoc | Charlie S0.2W | Des. | 15-Jan-03 |
| File | /nokia/sa_nmp/groups/p3047/rm-208/1yb/1yb_07/cellular/cmt_engine/rf_bb | Dr. | TKOIVUSA 03-Jan-07 |
| Proj | CBB5X | Sheet xx of yy | 0 (01) |
| | Drw. | Print Yes v. 0 | Edit 2 |

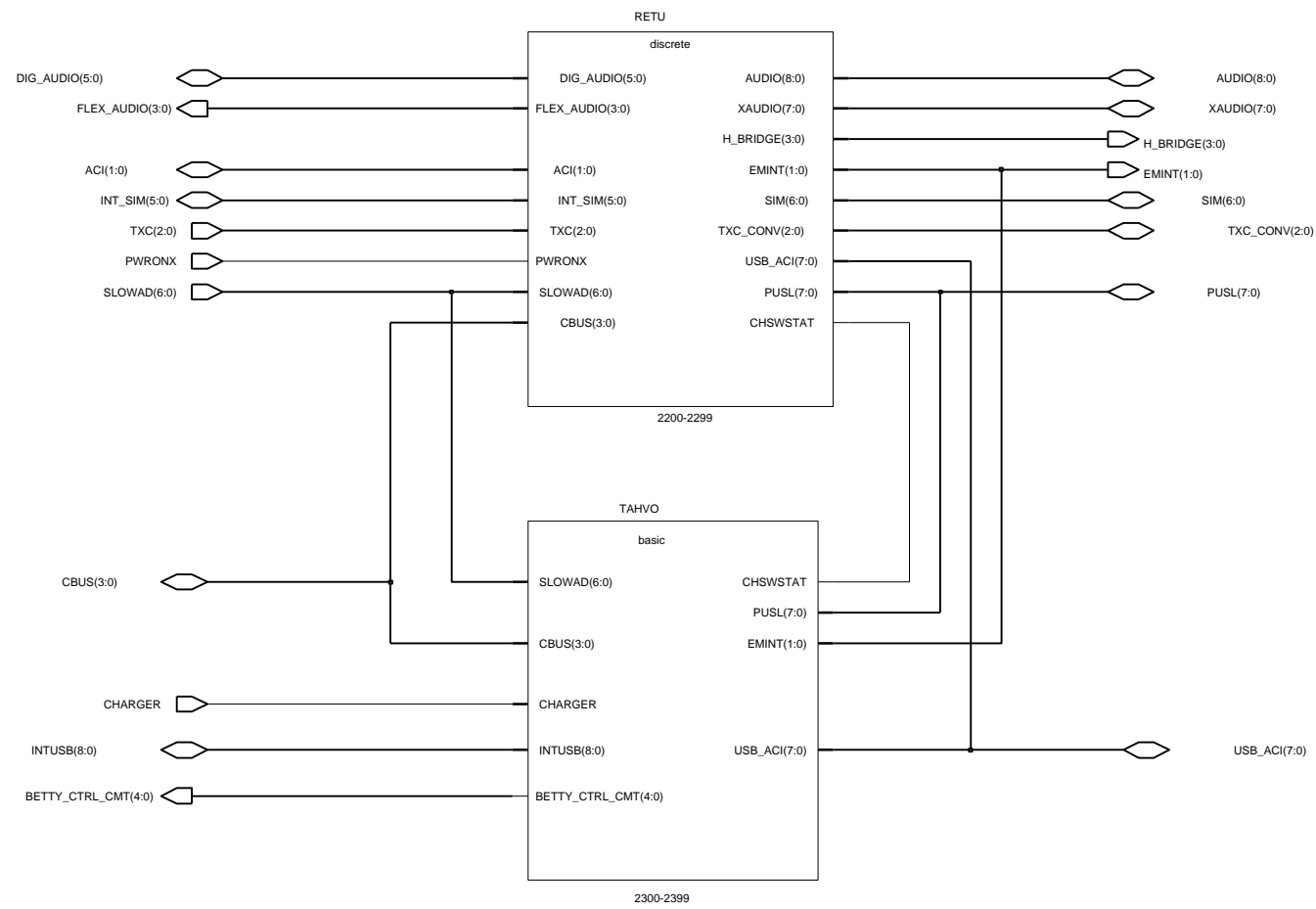

Copyright (C) Nokia Corporation. All rights reserved.
 THIS DRAWING IS PROTECTED BY COPYRIGHT AS AN UNPUBLISHED WORK.
 UNAUTHORIZED REPRODUCTION OF THIS DRAWING IS NOT PERMITTED.
 THIS DRAWING CONTAINS PROPRIETARY AND CONFIDENTIAL INFORMATION.
 This document is property of Nokia Corporation



| | | | |
|-------|--|-------|--------------------|
| Name | Energy management | Appr | dd-mmm-yy |
| Assoc | Vilbet | Des. | JARIM 26-May-04 |
| File | /nokia/sa_nmp/groups/p3047/rm-208/1yb/1yb_07/cellular/cmt_engine/power | Dr. | TKOIVUSA 03-Jan-07 |
| Proj | CeBBo2 | Sheet | xx of yy 1 (01) |
| | | Print | Yes v. Edit 2 |

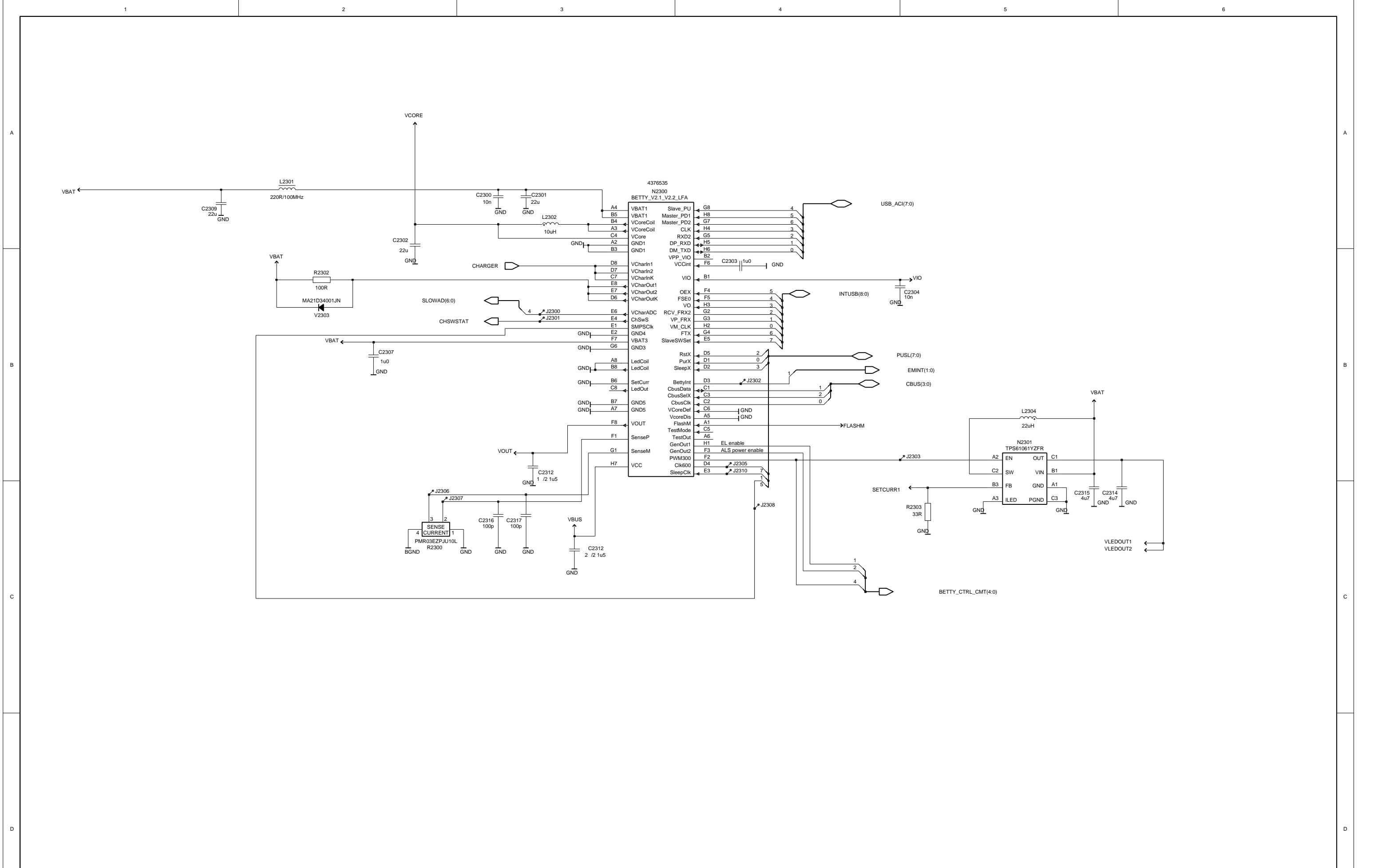

Copyright (C) Nokia Corporation. All rights reserved.
 THIS DRAWING IS PROTECTED BY COPYRIGHT AS AN UNPUBLISHED WORK.
 UNAUTHORIZED REPRODUCTION OF THIS DRAWING IS NOT PERMITTED.
 THIS DRAWING CONTAINS PROPRIETARY AND CONFIDENTIAL INFORMATION.
 This document is property of Nokia Corporation



| | | | |
|-------|--|-------|-----------------------|
| Name | Betty | Appr | 10-Aug-00 |
| Assoc | Vilbet | Des. | JARIM 10-May-04 |
| | | Dr. | TKOIVUSA 03-Jan-07 |
| File | /nokia/sa_nmp/groups/p3047/rm-208/1yb/1yb_07/cellular/cmt_engine/power/tahvo | | Sheet xx of yy 1 (01) |
| Proj | CeBBo2 | Print | Yes v. Edit 2 |

A

B

C

D

A

B

C

D

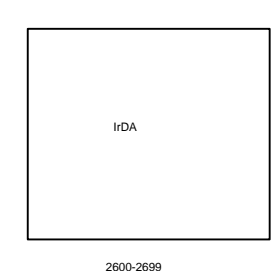
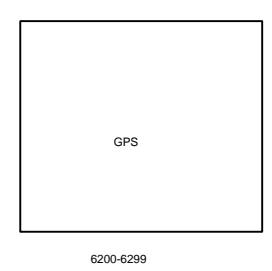
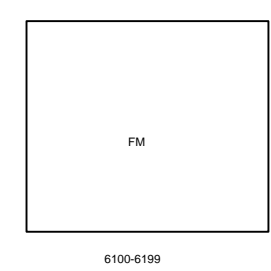
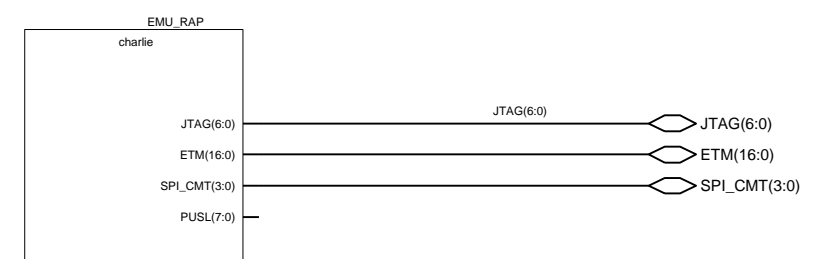
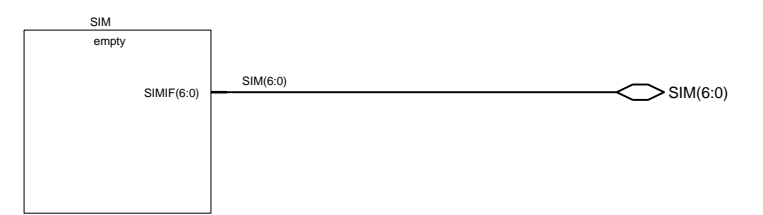
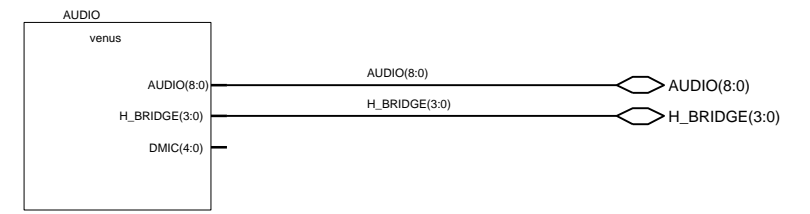
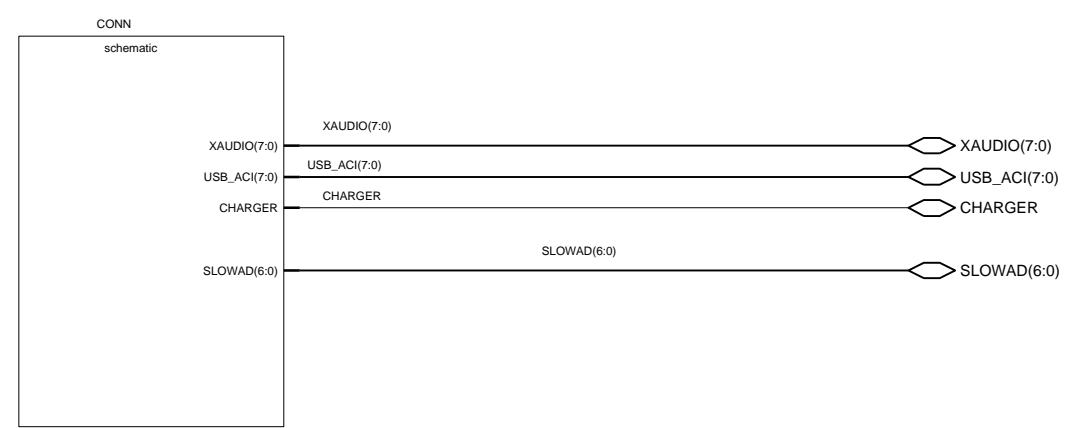

Copyright (C) Nokia Corporation. All rights reserved.
 THIS DRAWING IS PROTECTED BY COPYRIGHT AS AN UNPUBLISHED WORK.
 UNAUTHORIZED REPRODUCTION OF THIS DRAWING IS NOT PERMITTED.
 THIS DRAWING CONTAINS PROPRIETARY AND CONFIDENTIAL INFORMATION.
 This document is property of Nokia Corporation



| | | | |
|-------|--|-------|--------------------|
| Name | CMT_IF Top Level | Appr | dd-mmm-yy |
| Assoc | Engine Release Database | Des. | ArKa 27-May-03 |
| File | /nokia/sa_nmp/groups/p3047/rm-208/1yb/1yb_07/cellular/cmt_if | Dr. | TKOIVUSA 03-Jan-07 |
| Proj | Cement | Sheet | xx of yy 0 (01) |
| | | Print | Yes v. 0.0 Edit 2 |

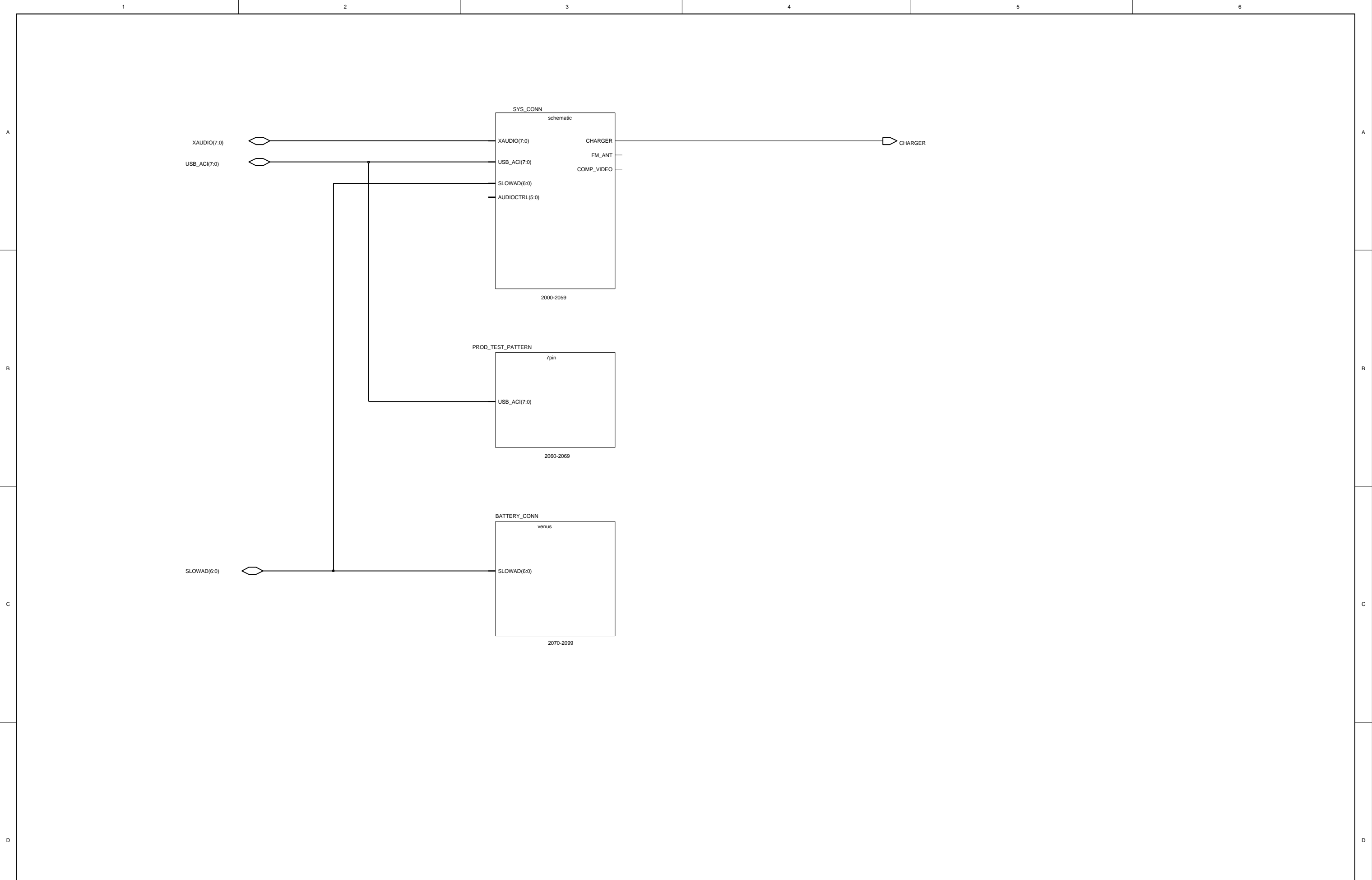

Copyright (C) Nokia Corporation. All rights reserved.
 THIS DRAWING IS PROTECTED BY COPYRIGHT AS AN UNPUBLISHED WORK.
 UNAUTHORIZED REPRODUCTION OF THIS DRAWING IS NOT PERMITTED.
 THIS DRAWING CONTAINS PROPRIETARY AND CONFIDENTIAL INFORMATION.
 This document is property of Nokia Corporation



| | | | |
|-------|---|------|-------------------------|
| Name | System and battery connector | Appr | 10-Aug-00 |
| Assoc | Charlie S0.6 | Des. | KAYRA 18-Jan-02 |
| | | Dr. | TKOIVUSA 03-Jan-07 |
| File | /nokia/sa_nmp/groups/p3047/rm-208/1yb/1yb_07/cellular/cmt_if/conn | | Sheet xx of yy 1 (01) |
| Proj | CBB5X | Drw. | Print Yes v. 0,1 Edit 2 |

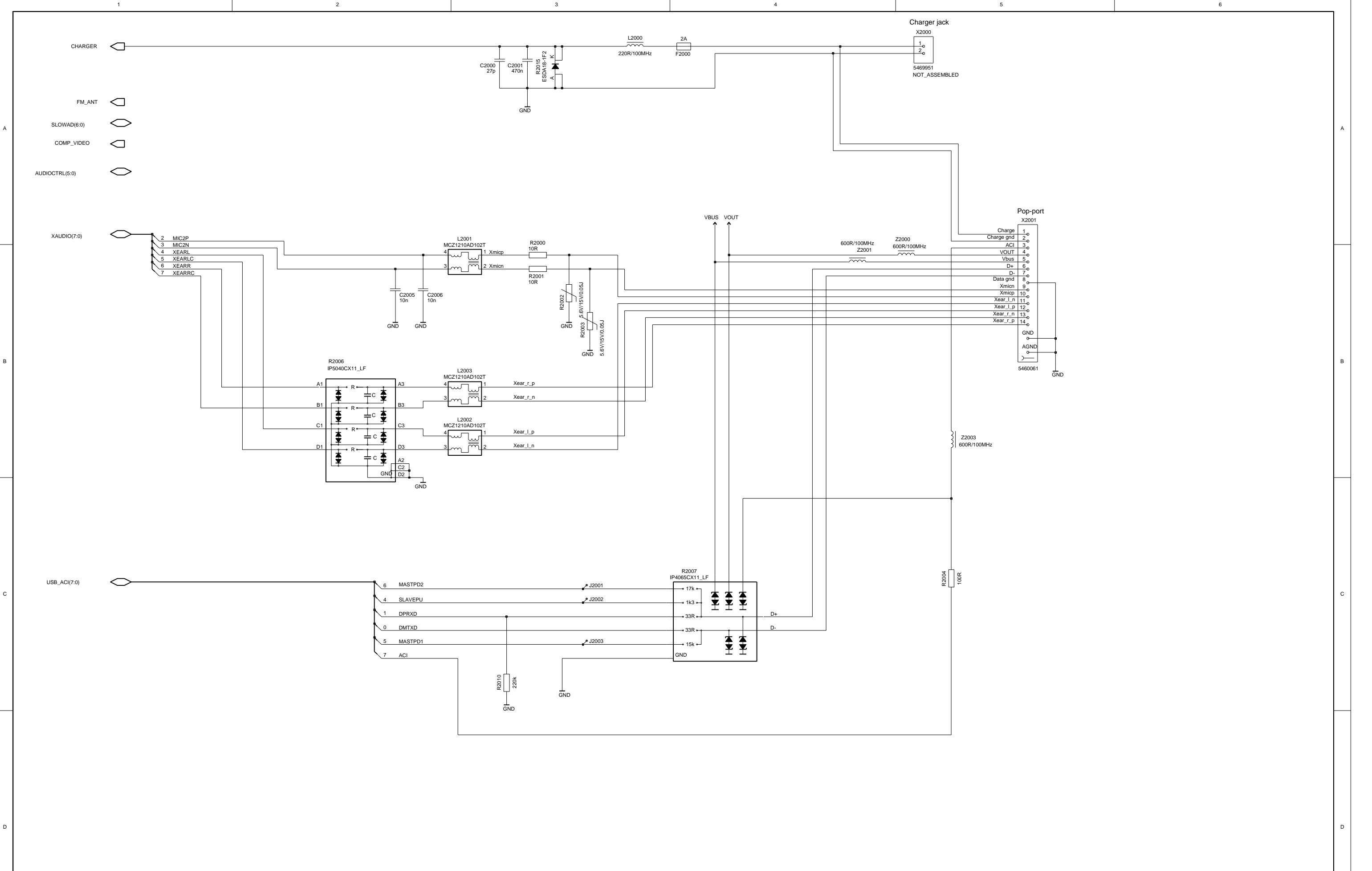

Copyright (C) Nokia Corporation. All rights reserved.
 THIS DRAWING IS PROTECTED BY COPYRIGHT AS AN UNPUBLISHED WORK.
 UNAUTHORIZED REPRODUCTION OF THIS DRAWING IS NOT PERMITTED.
 THIS DRAWING CONTAINS PROPRIETARY AND CONFIDENTIAL INFORMATION.
 This document is property of Nokia Corporation



| | | | |
|-------|---|-------|-----------------------|
| Name | System connector | Appr | 10-Aug-00 |
| Assoc | Vilbet | Des. | JARIM 10-May-04 |
| | | Dr. | TKOIVUSA 03-Jan-07 |
| File | /nokia/sa_nmp/groups/p3047/rm-208/1yb/1yb_07/cellular/cmt_if/sys_conn | | Sheet xx of yy 1 (01) |
| Proj | CeBBo2 | Print | Yes v. Edit 2 |

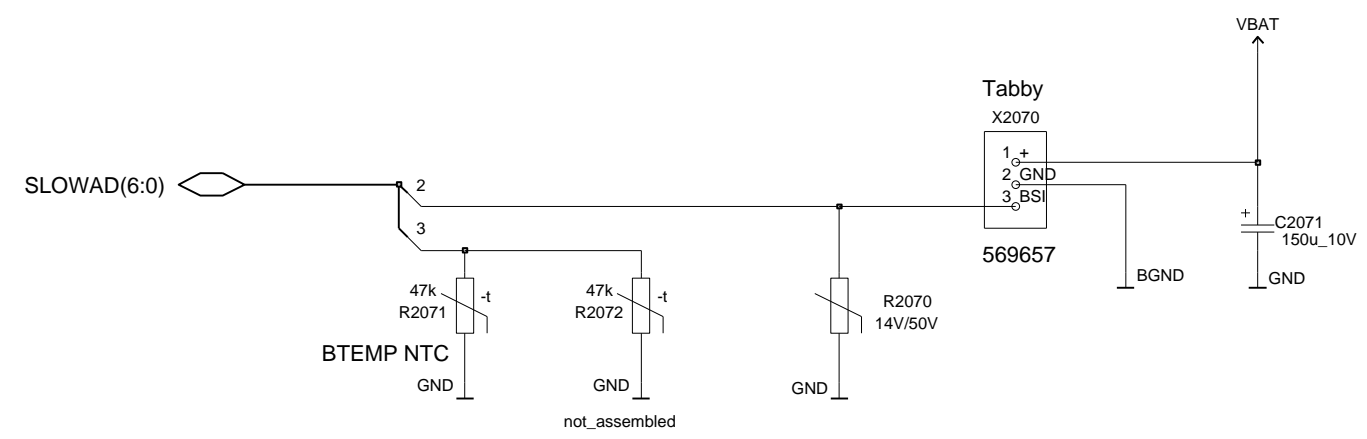

R2071 Placement is fixed according Thermal simulation. If placement need to be changed IT WILL NEED NEW SIMULATION !!!

| | | | | | | | |
|--|--|--|--|-------------------------|--|-------------------------|--|
| <p>Copyright (C) Nokia Corporation. All rights reserved. THIS DRAWING IS PROTECTED BY COPYRIGHT AS AN UNPUBLISHED WORK. UNAUTHORIZED REPRODUCTION OF THIS DRAWING IS NOT PERMITTED. THIS DRAWING CONTAINS PROPRIETARY AND CONFIDENTIAL INFORMATION. This document is property of Nokia Corporation</p> | | Name Battery connector | | Appr dd-mmm-yy | | | |
| | | Assoc | | Des. elahteen 04-Nov-05 | | | |
| | | | | Dr. TKOIVUSA 03-Jan-07 | | | |
| | | File /nokia/sa_nmp/groups/p3047/rm-208/1yb/1yb_07/cellular/cmt_if/battery_conn | | Sheet XX of yy 0 (01) | | | |
| | | Proj Postman | | Drw. | | Print Yes V. 0.0 Edit 2 | |
| | | | | | | | |

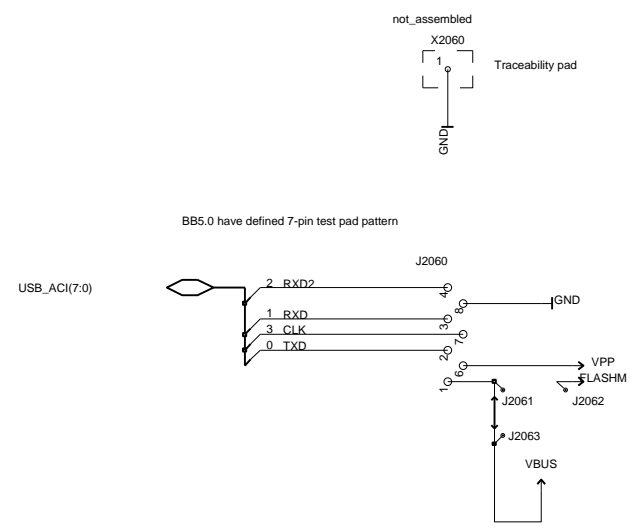

NOTE !! ABOUT VBUS & FLASHM PRODUCT SPECIFIC ISSUE !!!!
J2061-J2062 Should be placed as near as possible to each other
And signal between J2061 & J2062 Will be Left unrouted
This Way FlashM Can be Left as a backup for flashing activation

FLASHM = VBat; flashing possible
 FLASHM = floating; USB possible

Copyright (C) Nokia Corporation. All rights reserved.
 THIS DRAWING IS PROTECTED BY COPYRIGHT AS AN UNPUBLISHED WORK.
 UNAUTHORIZED REPRODUCTION OF THIS DRAWING IS NOT PERMITTED.
 THIS DRAWING CONTAINS PROPRIETARY AND CONFIDENTIAL INFORMATION.
 This document is property of Nokia Corporation



| | | | |
|-------|--|-------|-------------------------|
| Name | Production test pad | Appr | 10-Aug-00 |
| Assoc | Charlie S0.6 | Des. | KAYRA 18-Jan-02 |
| | | Dr. | TKOIVUSA 03-Jan-07 |
| File | /nokia/sa_nmp/groups/p3047/rm-208/1yb/1yb_07/cellular/cmt_if/prod_test_pattern | Sheet | xx of yy 1 (01) |
| Proj | CBB5X | Draw. | Print Yes v. 0,1 Edit 2 |

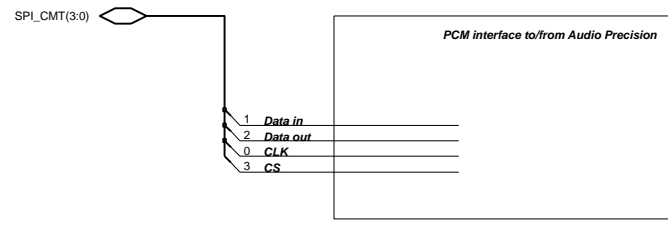
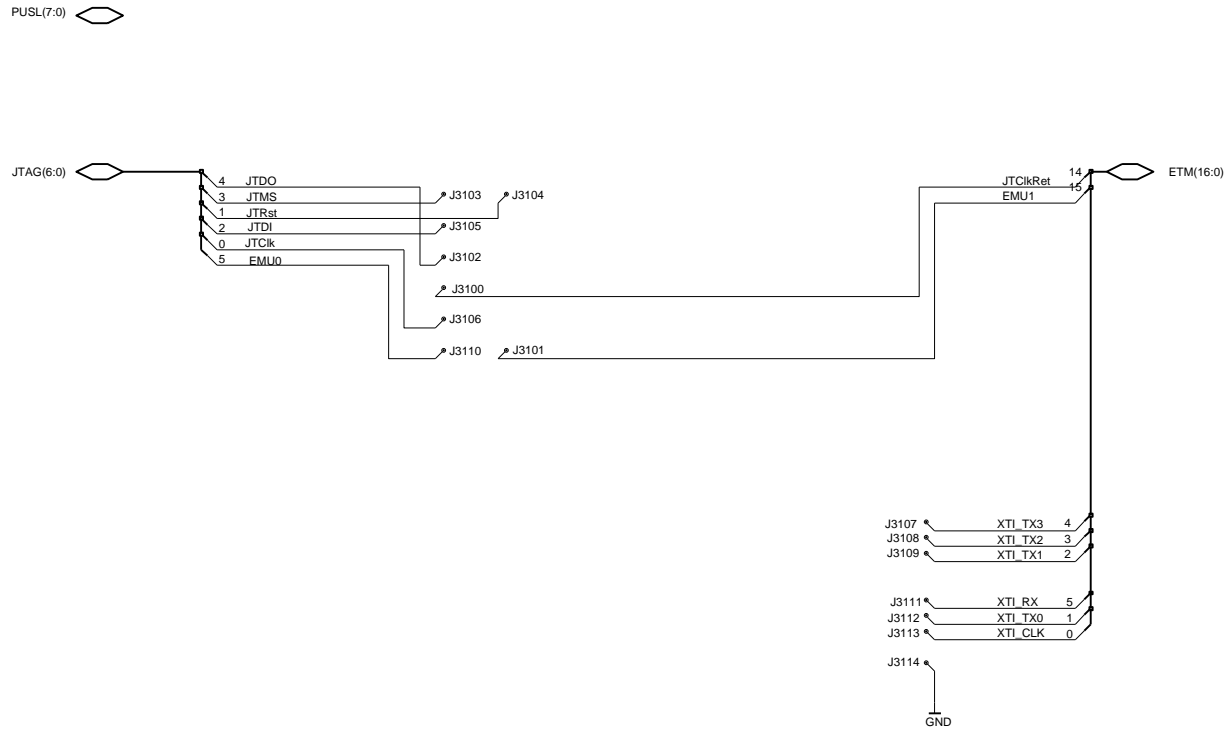

Copyright (C) Nokia Corporation. All rights reserved.
 THIS DRAWING IS PROTECTED BY COPYRIGHT AS AN UNPUBLISHED WORK.
 UNAUTHORIZED REPRODUCTION OF THIS DRAWING IS NOT PERMITTED.
 THIS DRAWING CONTAINS PROPRIETARY AND CONFIDENTIAL INFORMATION.
 This document is property of Nokia Corporation



| | | | |
|-------|--|------|-------------------------|
| Name | Test Interface | Appr | dd-mmm-yy |
| Assoc | Charlie S0.6 | Des. | KAYRA 04-Jun-98 |
| | | Dr. | TKOIVUSA 03-Jan-07 |
| File | /nokia/sa_nmp/groups/p3047/rm-208/1yb/1yb_07/cellular/cmt_if/emu_rap | | Sheet xx of yy 1 (01) |
| Proj | CBB5X | Drw. | Print Yes V. 1.3 Edit 2 |

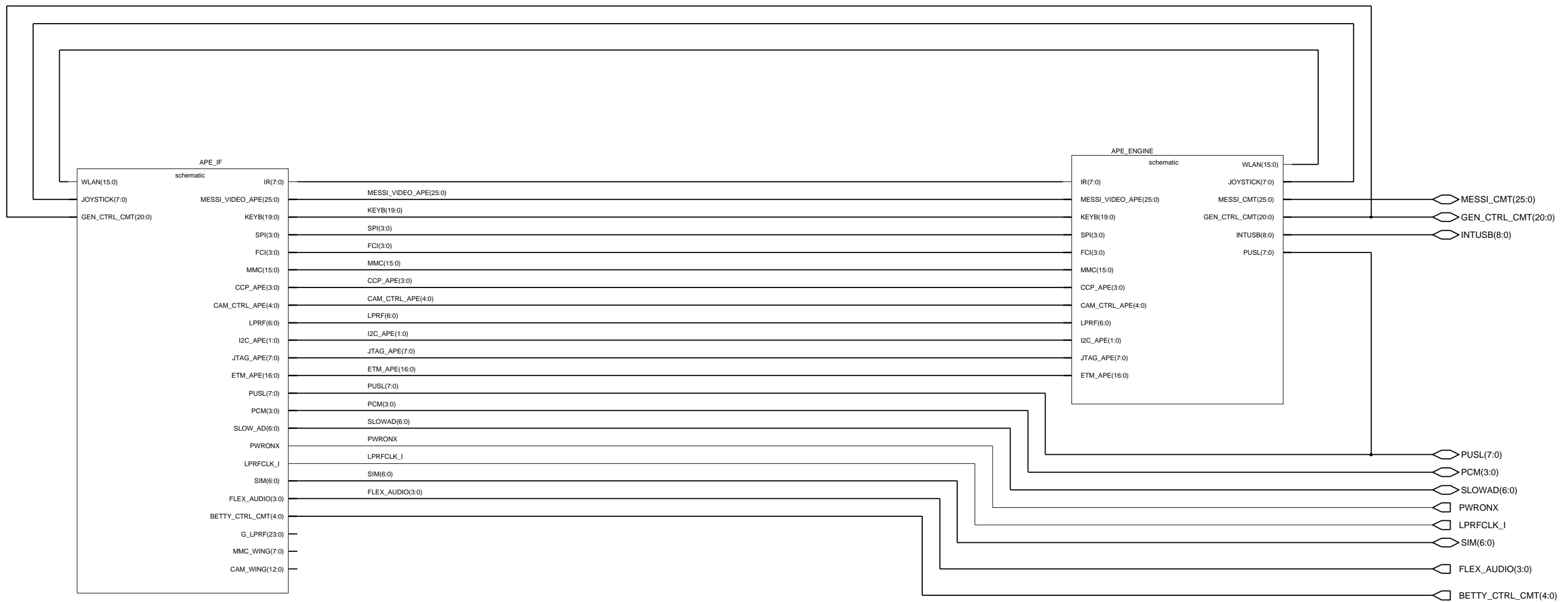

Copyright (C) Nokia Corporation. All rights reserved.
 THIS DRAWING IS PROTECTED BY COPYRIGHT AS AN UNPUBLISHED WORK.
 UNAUTHORIZED REPRODUCTION OF THIS DRAWING IS NOT PERMITTED.
 THIS DRAWING CONTAINS PROPRIETARY AND CONFIDENTIAL INFORMATION.
 This document is property of Nokia Corporation



| | | | |
|-------|--|-------|--------------------|
| Name | Revlon Top Level | Appr | dd-mmm-yy |
| Assoc | Revlon Application Engine | Des. | KAYRA 27-Aug-03 |
| File | /nokia/sa_nmp/groups/p3047/rm-208/1yb/1yb_07/ape | Dr. | TKOIVUSA 03-Jan-07 |
| Proj | Revlon | Sheet | xx of yy 0 (01) |
| | | Print | Yes v. 0.0 Edit 2 |

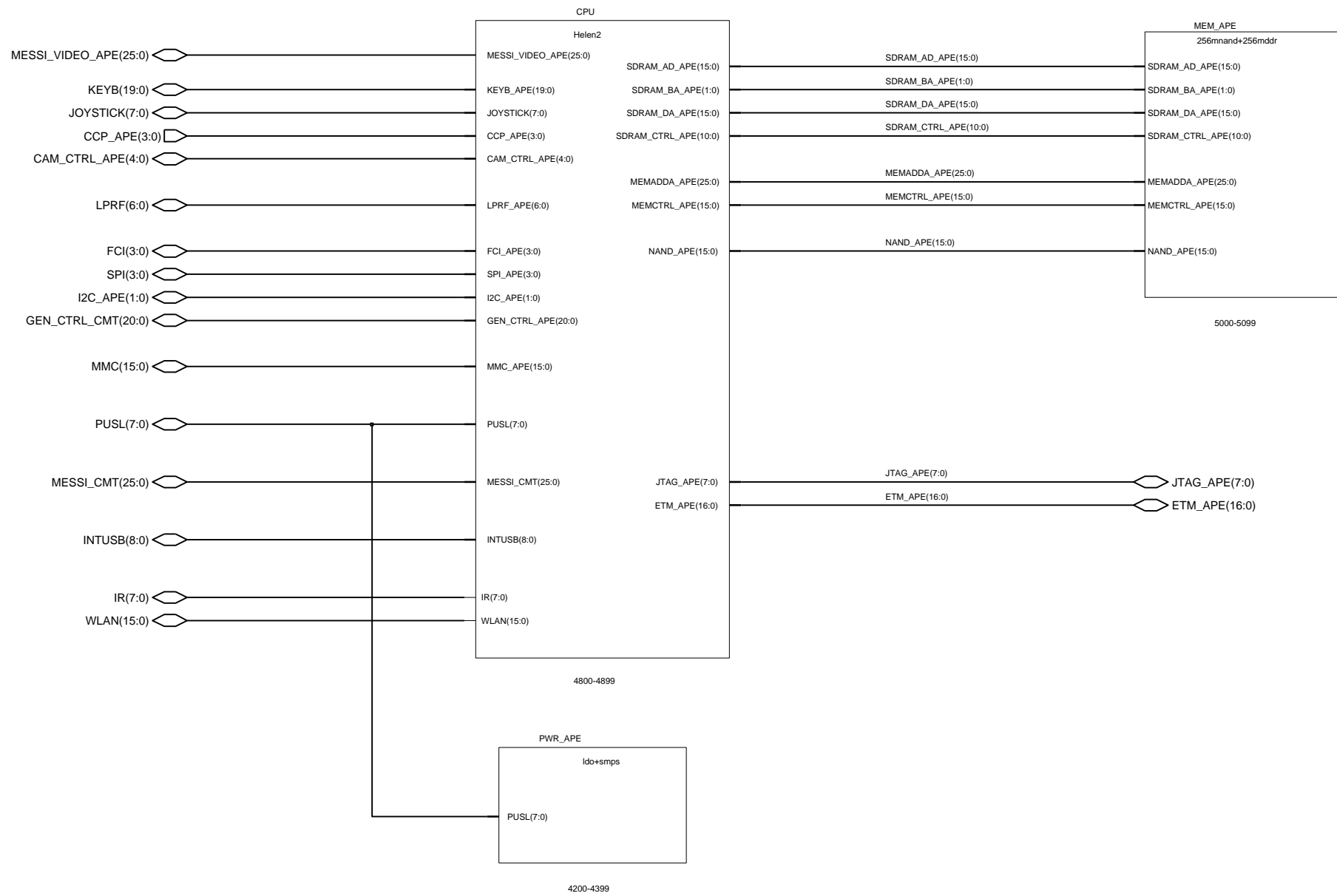

Copyright (C) Nokia Corporation. All rights reserved.
 THIS DRAWING IS PROTECTED BY COPYRIGHT AS AN UNPUBLISHED WORK.
 UNAUTHORIZED REPRODUCTION OF THIS DRAWING IS NOT PERMITTED.
 THIS DRAWING CONTAINS PROPRIETARY AND CONFIDENTIAL INFORMATION.
 This document is property of Nokia Corporation



| | | | |
|-------|---|-------|--------------------|
| Name | Ape Engine | Appr | dd-mmm-yy |
| Assoc | Revlon Application Engine | Des. | KAYRA 27-Aug-03 |
| File | /nokia/sa_nmp/groups/p3047/rm-208/1yb/1yb_07/ape/ape_engine | Dr. | TKOIVUSA 03-Jan-07 |
| Proj | Revlon | Sheet | xx of yy 0 (01) |
| | | Print | Yes v. 0.0 Edit 2 |

A

B

C

D

A

B

C

D

MEMADDA_APE(25:0)

MEMCTRL_APE(15:0)

SDRAM_AD_APE(15:0)

SDRAM_CTRL_APE(10:0)

SDRAM_BA_APE(1:0)

NAND_APE(15:0)

SDRAM_DA_APE(15:0)

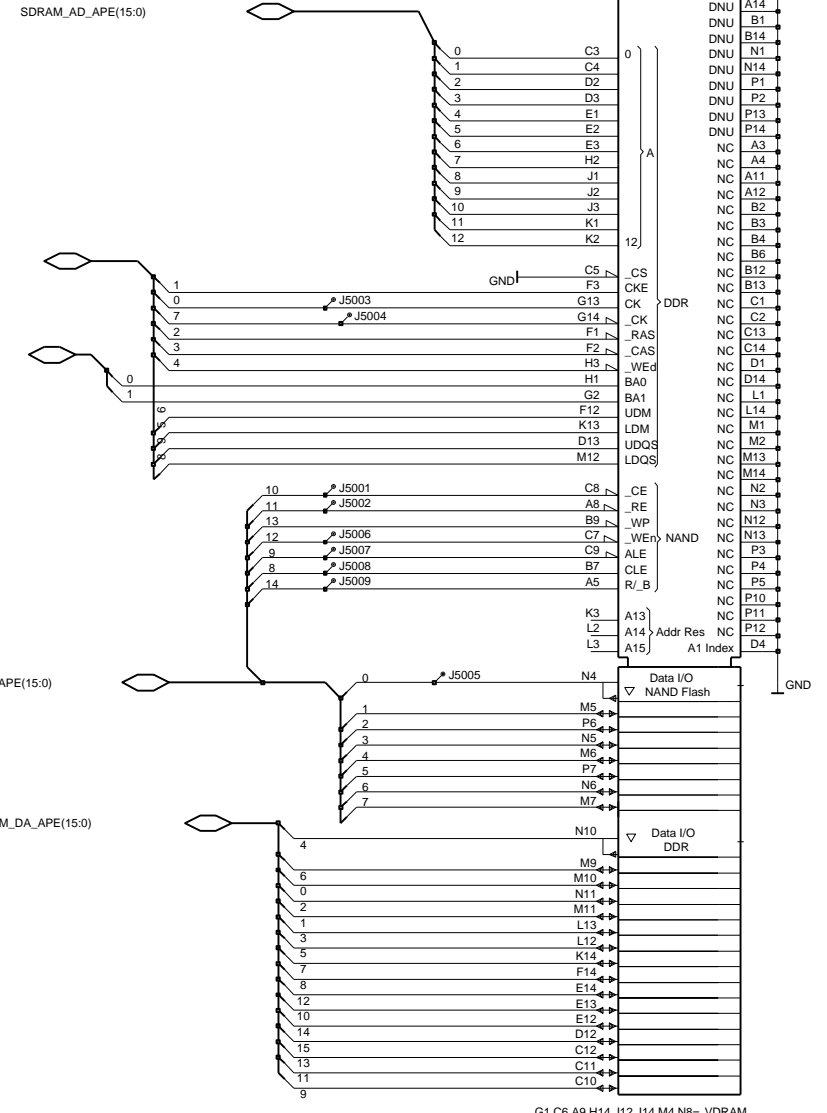

G1,C6,A9,H14,J12,J14,M4,N8= VDRAM
 B11,M8,H13,J13= VIO
 A6= VIO
 N7= VIO
 B5,B10,G3,G12,H12,M3,N9= GND
 A10,F13,K12,P9= GND
 A7,B8,P8= GND

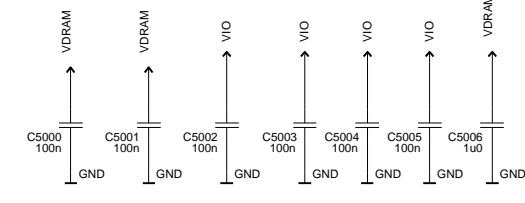

| | | | | | | | |
|---|--|------|--|---|--|--|--|
| Copyright (C) Nokia Corporation. All rights reserved. THIS DRAWING IS PROTECTED BY COPYRIGHT AS AN UNPUBLISHED WORK. UNAUTHORIZED REPRODUCTION OF THIS DRAWING IS NOT PERMITTED. THIS DRAWING CONTAINS PROPRIETARY AND CONFIDENTIAL INFORMATION. This document is property of Nokia Corporation | | | | Name APE Memories Assoc Charlie S0.6 | | Appr 10-Aug-00 Des. KAYRA 11-Apr-2001 Dr. TKOIVUSA 03-Jan-07 | |
| File /nokia/sa_nmp/groups/p3047/rm-208/1yb/1yb_07/ape/ape_engine/mem_ape | | | | Sheet xx of yy 1 (01) | | Print Yes V. 0,1 Edit 2 | |
| Proj CBB5X | | Drw. | | | | | |

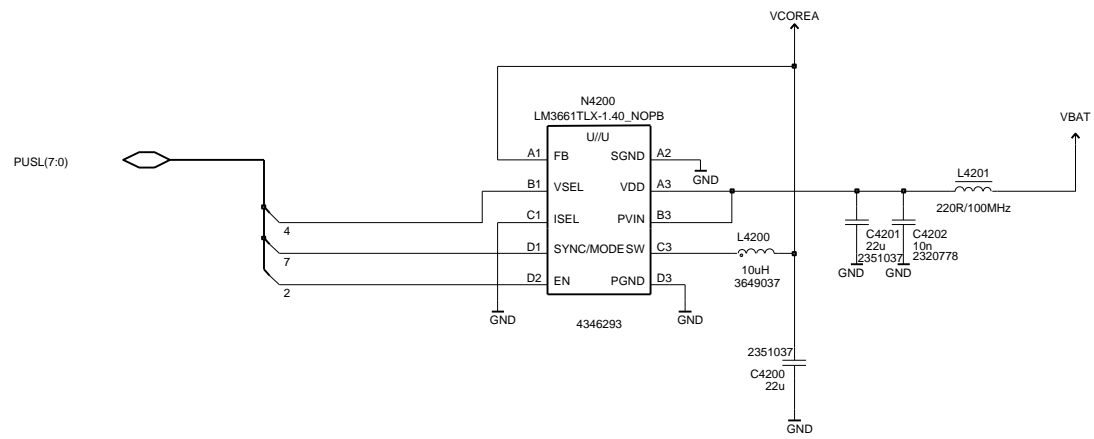

Copyright (C) Nokia Corporation. All rights reserved.
 THIS DRAWING IS PROTECTED BY COPYRIGHT AS AN UNPUBLISHED WORK.
 UNAUTHORIZED REPRODUCTION OF THIS DRAWING IS NOT PERMITTED.
 THIS DRAWING CONTAINS PROPRIETARY AND CONFIDENTIAL INFORMATION.
 This document is property of Nokia Corporation



| | | | |
|-------|---|------|-------------------------|
| Name | Discrete regulators | Appr | 10-Aug-00 |
| Assoc | Charlie S0.6 | Des. | KAYRA 15-Jan-03 |
| | | Dr. | TKOIVUSA 03-Jan-07 |
| File | /nokia/sa_nmp/groups/p3047/rm-208/1yb/1yb_07/ape/ape_engine/pwr_ape | | Sheet xx of yy 1 (00) |
| Proj | CBB5X | Drw. | Print Yes V. 0,1 Edit 2 |

See Helen2_3 uses cases before remapping pins
 Not pin compatible with Helen3 (OMAP1710)

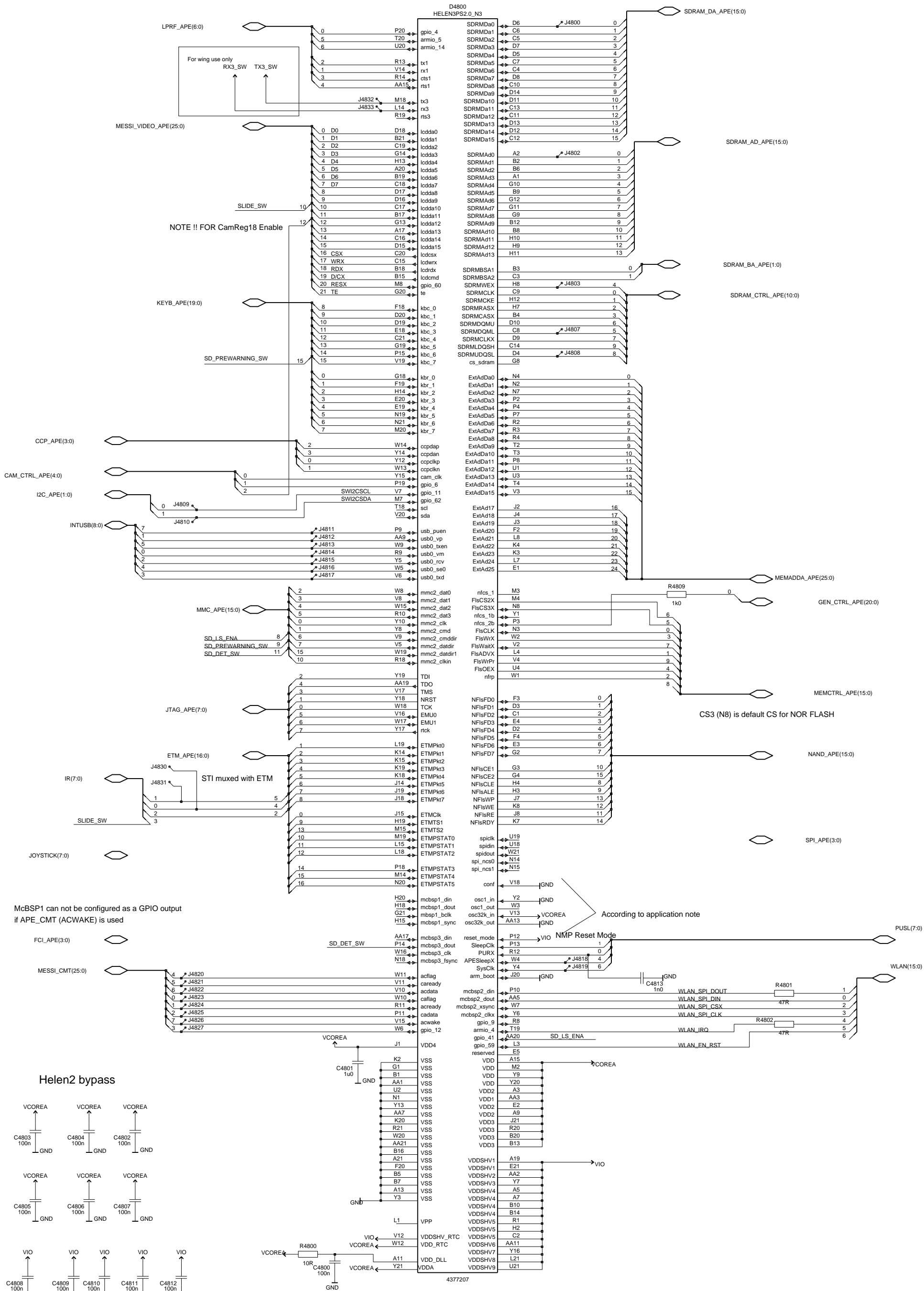

Copyright (C) Nokia Corporation. All rights reserved.
 THIS DRAWING IS PROTECTED BY COPYRIGHT AS AN UNPUBLISHED WORK.
 UNAUTHORIZED REPRODUCTION OF THIS DRAWING IS NOT PERMITTED.
 THIS DRAWING CONTAINS PROPRIETARY AND CONFIDENTIAL INFORMATION.
 This document is property of Nokia Corporation



| | | | |
|-------|---|-------|--------------------|
| Name | Helen2 | Appr | dd-mmm-yy |
| Assoc | 1yb | Des. | KAYRA 27-Aug-03 |
| | | Tech | Revlon |
| | | Dr. | TKOIVUSA 03-Jan-07 |
| File | /nokia/sa_nmp/groups/p3047/rm-208/1yb/1yb_07/ape/ape_engine/cpu | Sheet | xx of yy 1 (01) |
| Proj | AFRODITE | Print | Yes V. 02 Edit 2 |

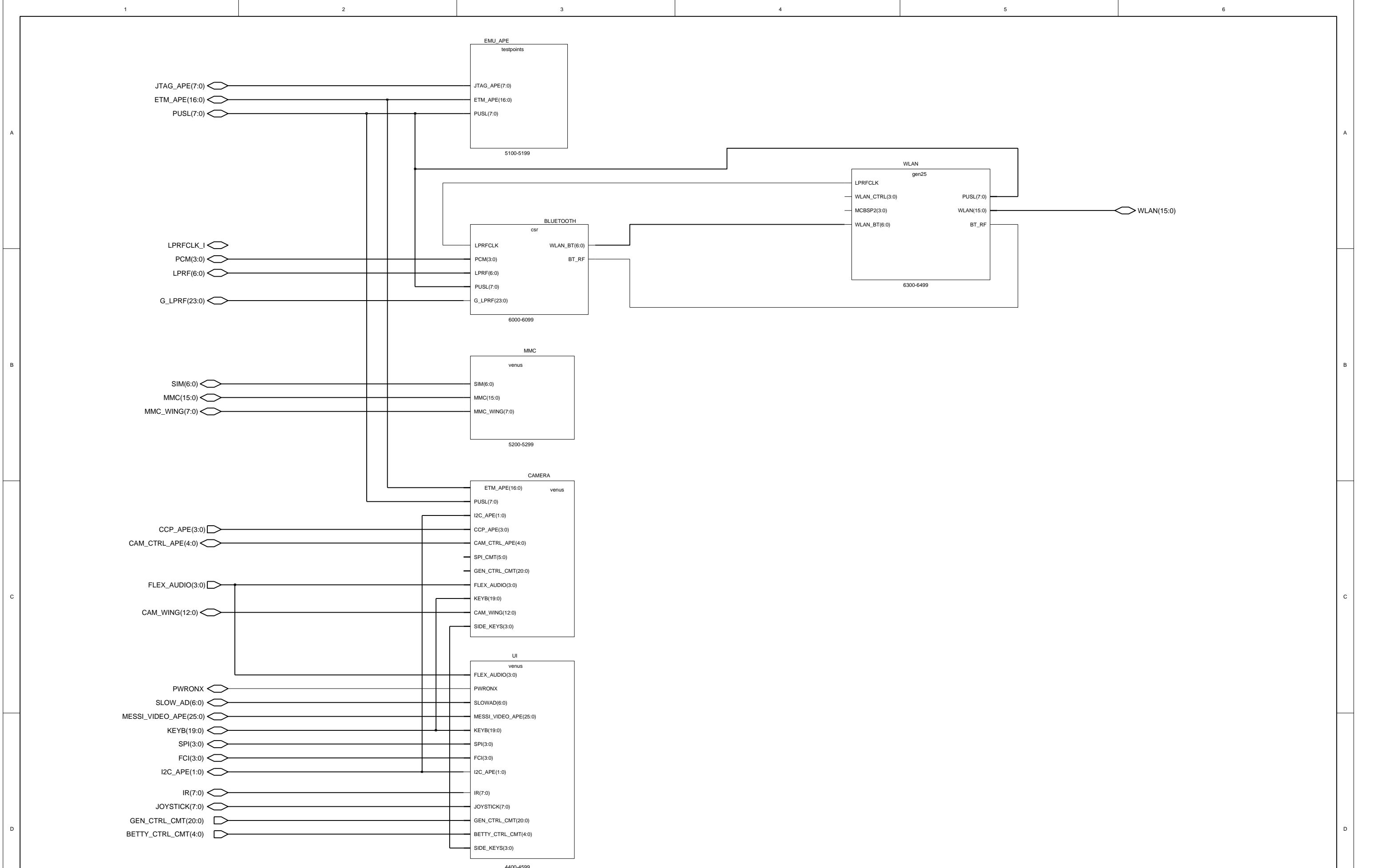

Copyright (C) Nokia Corporation. All rights reserved.
 THIS DRAWING IS PROTECTED BY COPYRIGHT AS AN UNPUBLISHED WORK.
 UNAUTHORIZED REPRODUCTION OF THIS DRAWING IS NOT PERMITTED.
 THIS DRAWING CONTAINS PROPRIETARY AND CONFIDENTIAL INFORMATION.
 This document is property of Nokia Corporation



| | | | |
|-------|---|-------|--------------------|
| Name | | Appr | dd-mmm-yy |
| Assoc | | Des. | 27-May-03 |
| | | Dr. | TKOIVUSA 03-Jan-07 |
| File | /nokia/sa_nmp/groups/p3047/rm-208/1yb/1yb_07/ape/ape_if | Sheet | xx of yy 01 |
| Proj | | Print | Yes v. 0.0 Edit 2 |

STV984

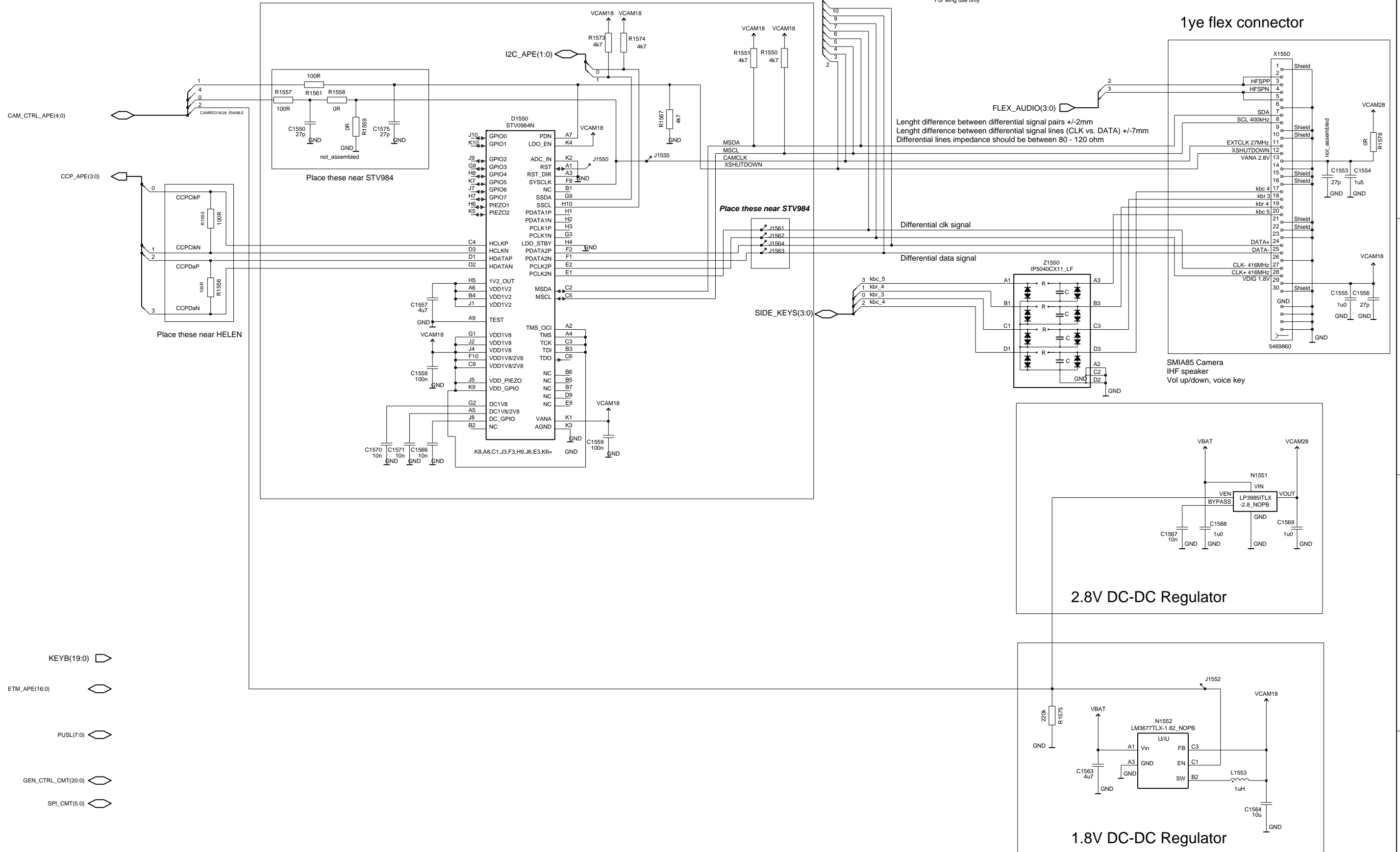

Copyright (C) Nokia Corporation. All rights reserved.
 THIS DRAWING IS PROTECTED BY COPYRIGHT AS AN UNPUBLISHED WORK.
 UNAUTHORIZED REPRODUCTION OF THIS DRAWING IS NOT PERMITTED.
 THIS DRAWING CONTAINS PROPRIETARY AND CONFIDENTIAL INFORMATION.
 This document is property of Nokia Corporation



| | | | |
|-------|--|-------|--------------------|
| Name | STV984+SMA85 | Appr | dd-mmm-yy |
| Assoc | 1yb | Des. | elahteen 04-Nov-05 |
| File | /nokia/sa_nmp/groups/p3047/rm-208/1yb/1yb_07/ape/ape_if/camera | Dr. | TKOIVUSA 03-Jan-07 |
| Proj | AFRODITE | Sheet | xx of yy 0 (01) |
| Draw. | | Print | Yes v. 0.0 Edit 3 |

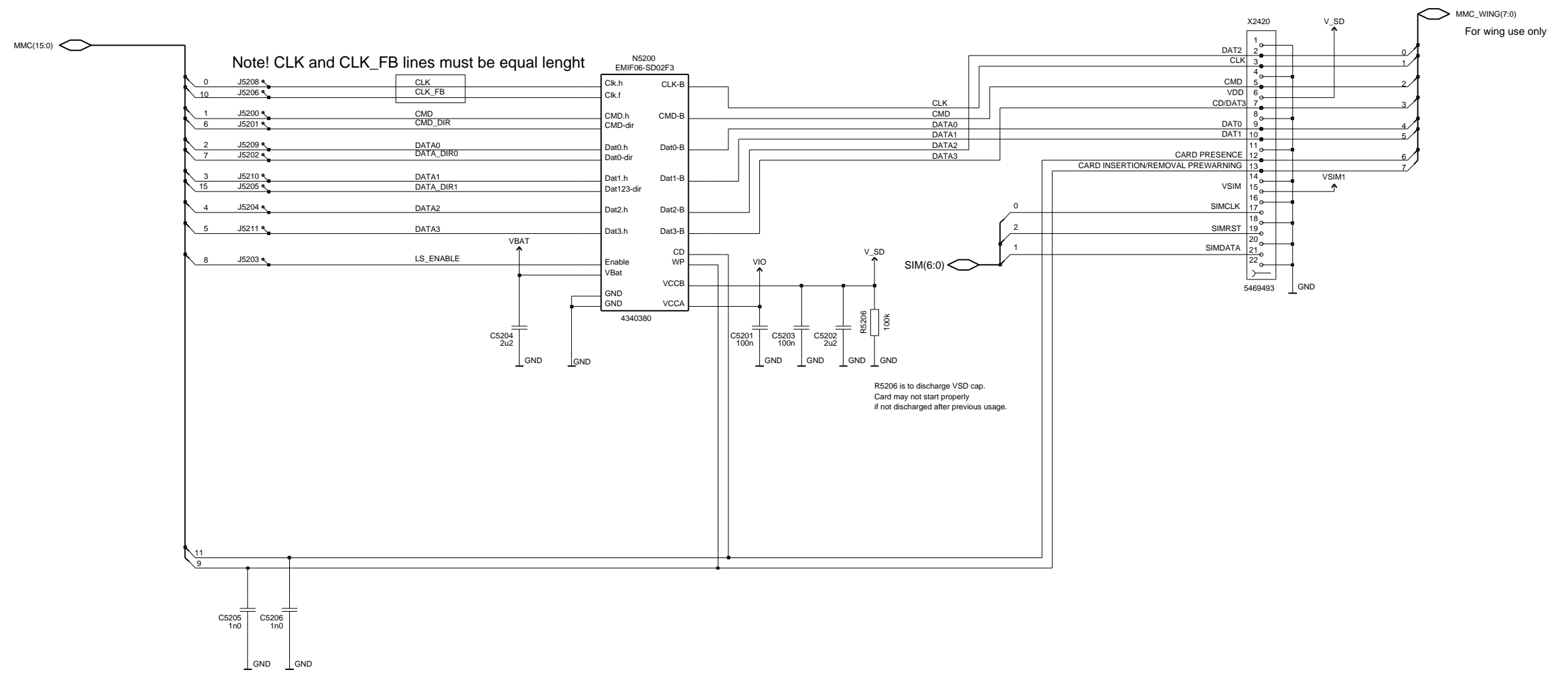

Place close to corresponding pins of Helen

| | | | | | | | |
|---|--|--|--|--|--|---|--|
| Copyright (C) Nokia Corporation. All rights reserved. THIS DRAWING IS PROTECTED BY COPYRIGHT AS AN UNPUBLISHED WORK. UNAUTHORIZED REPRODUCTION OF THIS DRAWING IS NOT PERMITTED. THIS DRAWING CONTAINS PROPRIETARY AND CONFIDENTIAL INFORMATION. This document is property of Nokia Corporation | | | | Name MMC Assoc 1ax Tech Revlon File /nokia/sa_nmp/groups/p3047/rm-208/1yb/1yb_07/ape/ape_if/mmc Proj CHARLIE | | Appr dd-mmm-yy Des. KAYRA 11-Apr-2001 Dr. TKOIVUSA 03-Jan-07 Sheet xx of yy 1 (01) Print Yes v. 02 Edit 3 | |
|---|--|--|--|--|--|---|--|

JOYSTICK(7:0)

I2C_APE(1:0)

SPI(3:0)

FC(3:0)

MESSI_VIDEO_APE(25:0)

Module has 33kOhm internal resistor in enable line together with R4402 they will limit enable current.
 Small current => EL lamp will discharge slowly => a bit dimmer lamp and less audible noise
 Enable current must be between 10 - 50uA, with 82k external resistor current will be 27.8 - 36.5uA
 (VBAT varying between 3.2 - 4.2V)

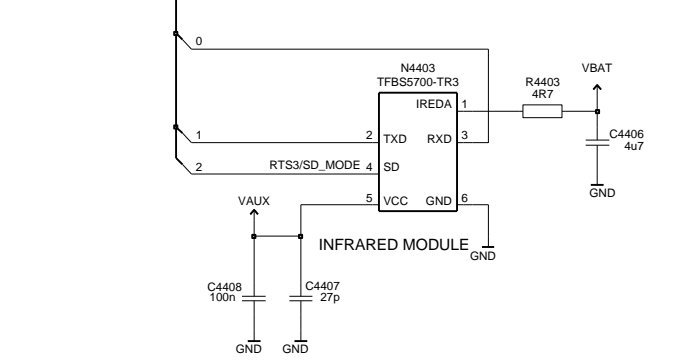
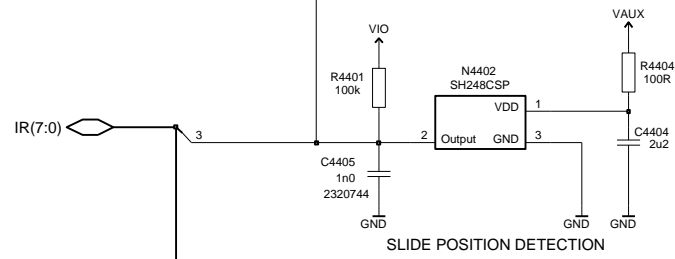
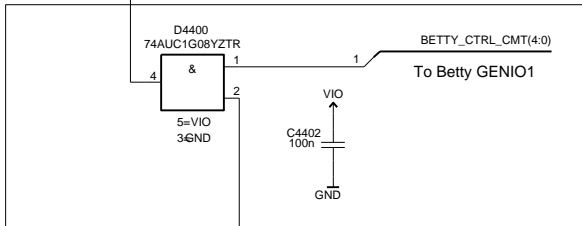
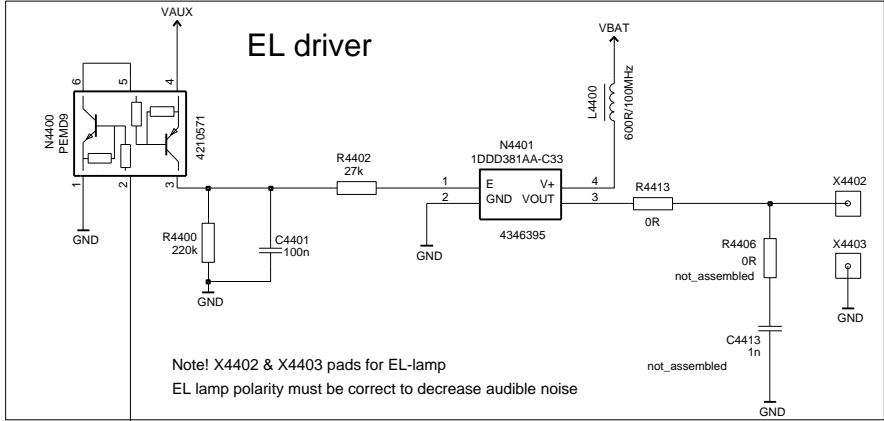

KEYB(19:0)

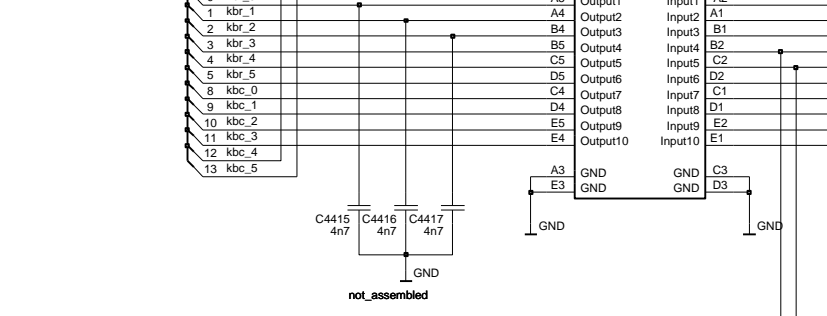

SIDE_KEYS(3:0)

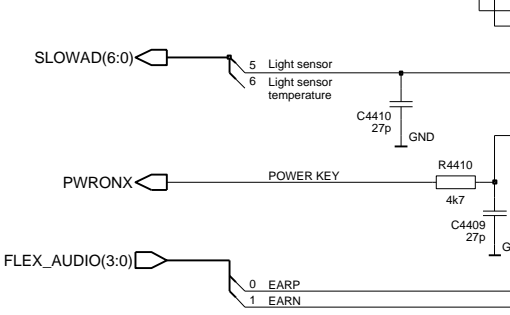
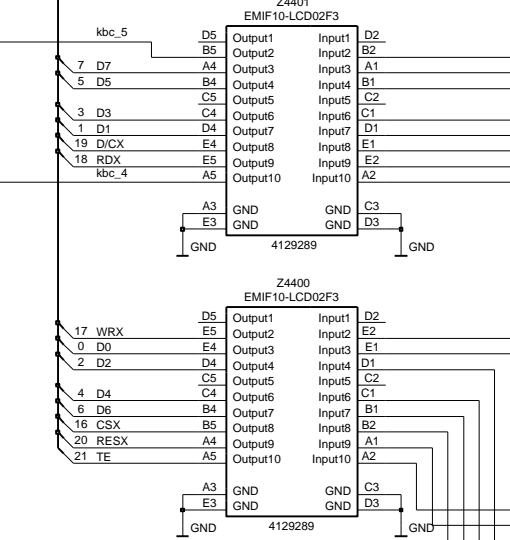

FLEX_AUDIO(3:0)

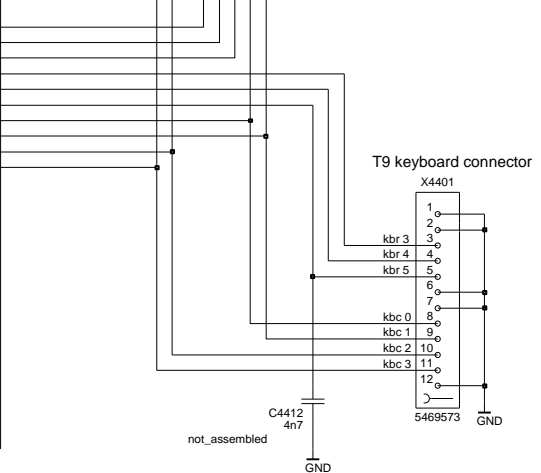
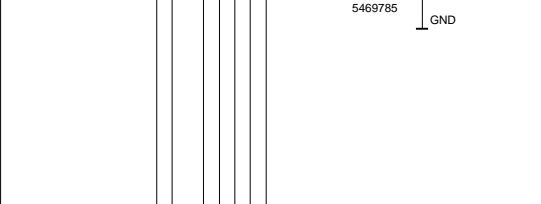
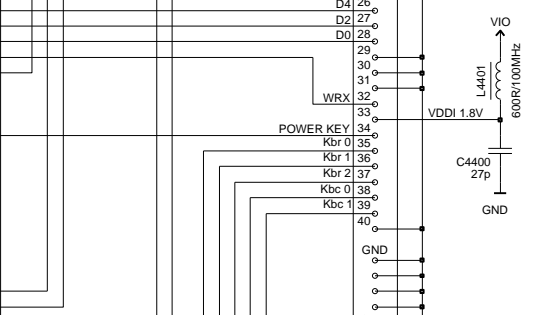
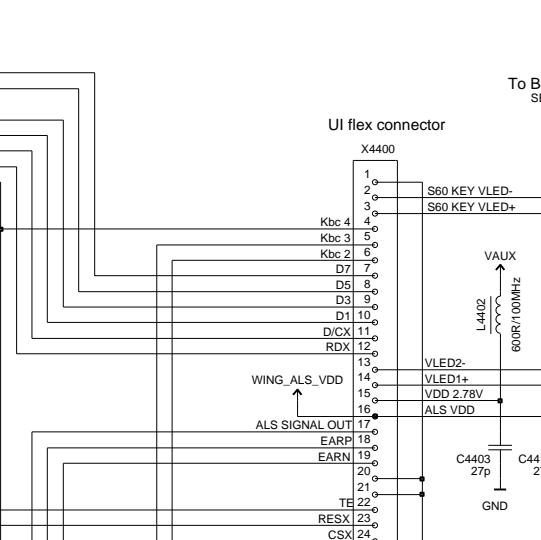

UI flex connector

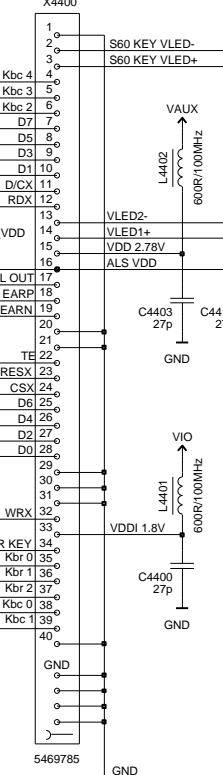

To Betty sheet SETCURR1

From Betty sheet VLEDOUT1

S60 & T9 keypad lighting constant current circuit

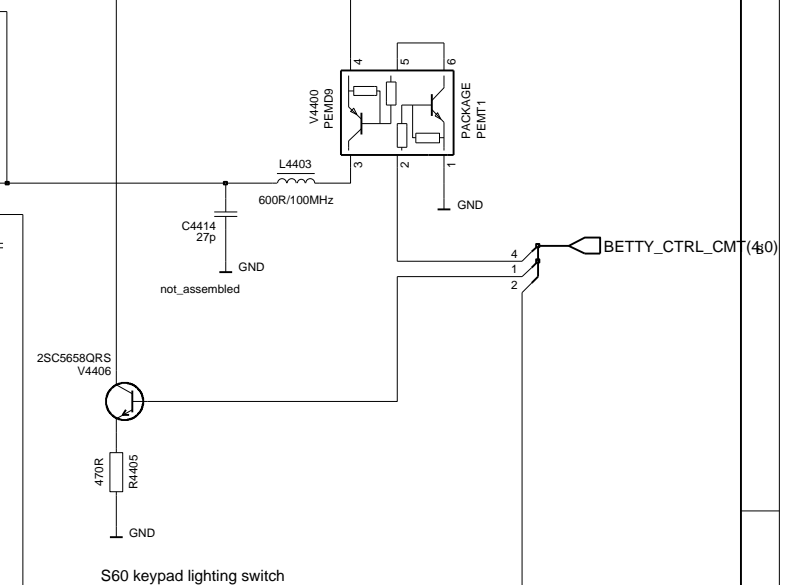

BETTY_CTRL_CMT(4:0)

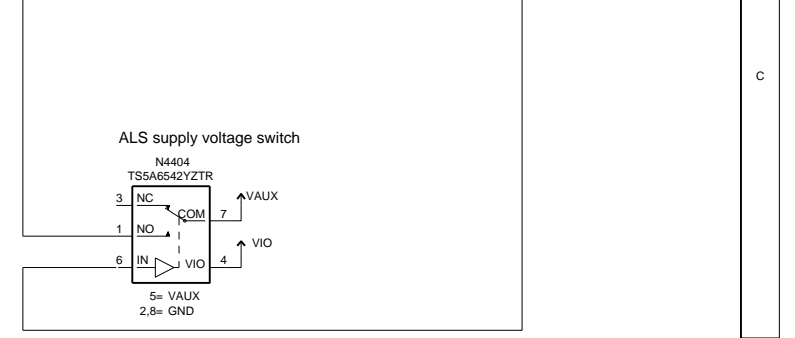

To Betty GENIO2 aligned with other projects

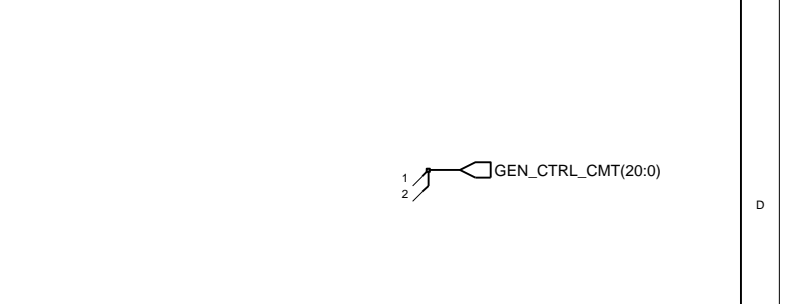

Copyright (C) Nokia Corporation. All rights reserved.
 THIS DRAWING IS PROTECTED BY COPYRIGHT AS AN UNPUBLISHED WORK.
 UNAUTHORIZED REPRODUCTION OF THIS DRAWING IS NOT PERMITTED.
 THIS DRAWING CONTAINS PROPRIETARY AND CONFIDENTIAL INFORMATION.
 This document is property of Nokia Corporation



| | | | |
|-------|--|-------|--------------|
| Name | UI | Appr | dd-mmm-yy |
| Assoc | 1yb | Des. | 15-Jan-03 |
| | | Tech | Revlon |
| File | /nokia/sa_nmp/groups/p3047/rm-208/1yb/1yb_07/ape/ape_if/ui | | Dr. TKOIVUSA |
| Proj | AFRODITE | Sheet | xx of yy |
| | | Print | Yes |
| | | V. | 02 |
| | | Edit | 2 |

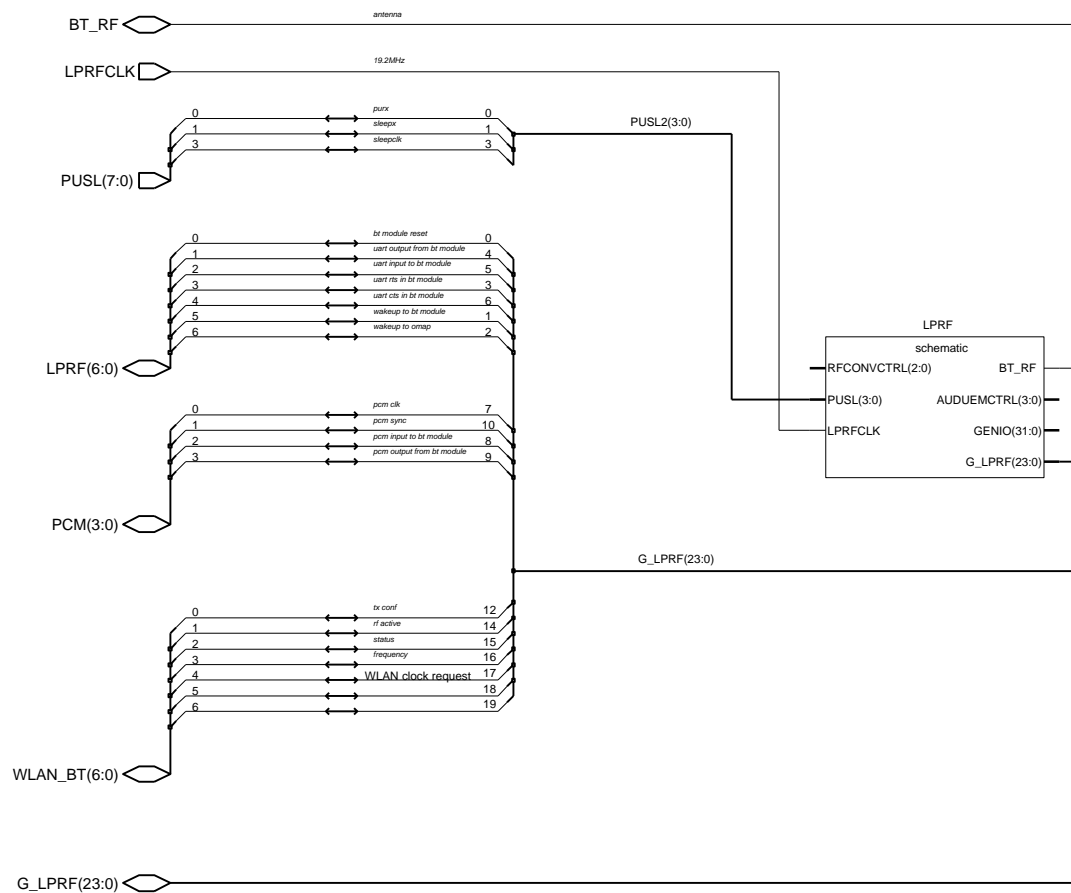

Copyright (C) Nokia Corporation. All rights reserved.
 THIS DRAWING IS PROTECTED BY COPYRIGHT AS AN UNPUBLISHED WORK.
 UNAUTHORIZED REPRODUCTION OF THIS DRAWING IS NOT PERMITTED.
 THIS DRAWING CONTAINS PROPRIETARY AND CONFIDENTIAL INFORMATION.
 This document is property of Nokia Corporation



| | | | |
|-------|---|-------|--------------------|
| Name | CSR Bluetooth Interface | Appr | dd-mmm-yy |
| Assoc | | Des. | KAYRA 29-Aug-03 |
| | Tech BlueBird | Dr. | TKOIVUSA 03-Jan-07 |
| File | /nokia/sa_nmp/groups/p3047/rm-208/1yb/1yb_07/ape/ape_if/bluetooth | Sheet | xx of yy 0 (01) |
| Proj | Drw. | Print | Yes v. 02 Edit 2 |

BTHCOST_3.0 (TI NON-BUFF)

BLUETOOTH CIRCUIT

- RFCONVCTRL(2:0)
- AUDUEMCTRL(3:0)
- GENIO(31:0)

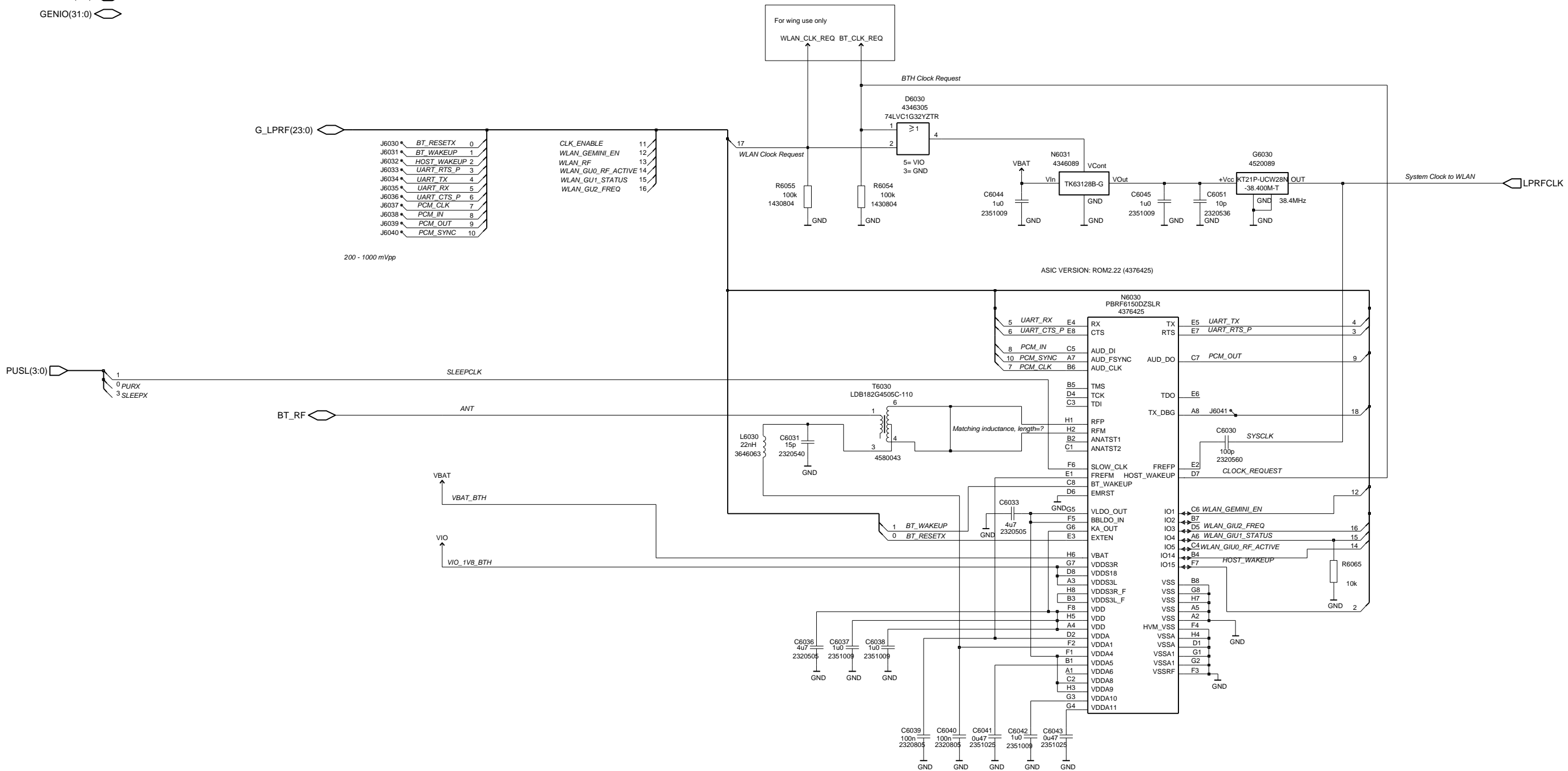

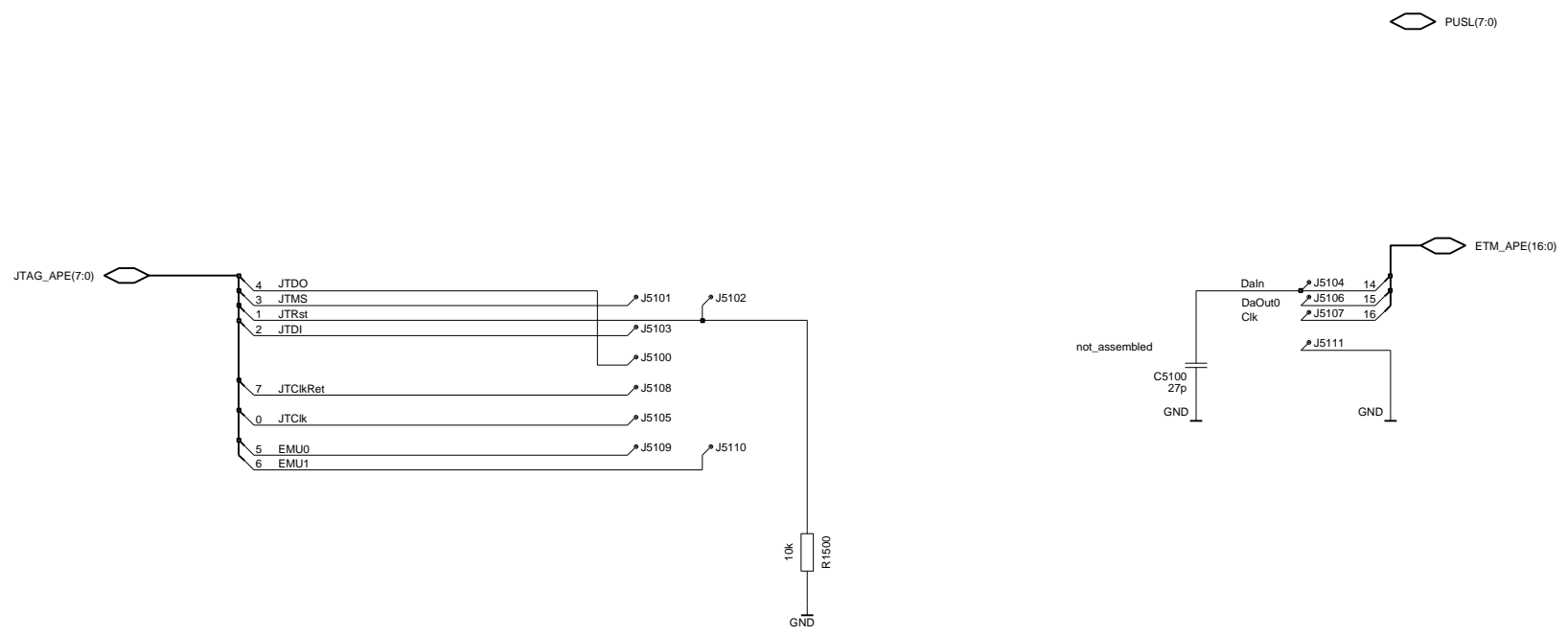

Copyright (C) Nokia Corporation. All rights reserved.
 THIS DRAWING IS PROTECTED BY COPYRIGHT AS AN UNPUBLISHED WORK.
 UNAUTHORIZED REPRODUCTION OF THIS DRAWING IS NOT PERMITTED.
 THIS DRAWING CONTAINS PROPRIETARY AND CONFIDENTIAL INFORMATION.
 This document is property of Nokia Corporation



| | | | |
|-------|---|------|------------------------|
| Name | JTAG + ETM | Appr | dd-mmm-yy |
| Assoc | 1yb | Des. | ILJARVIN 29-Aug-03 |
| | | Dr. | TKOIVUSA 03-Jan-07 |
| File | /nokia/sa_nmp/groups/p3047/rm-208/1yb/1yb_07/ape/ape_if/emu_ape | | Sheet xx of yy 1 (01) |
| Proj | AFRODITE | Drw. | Print Yes v. 02 Edit 2 |

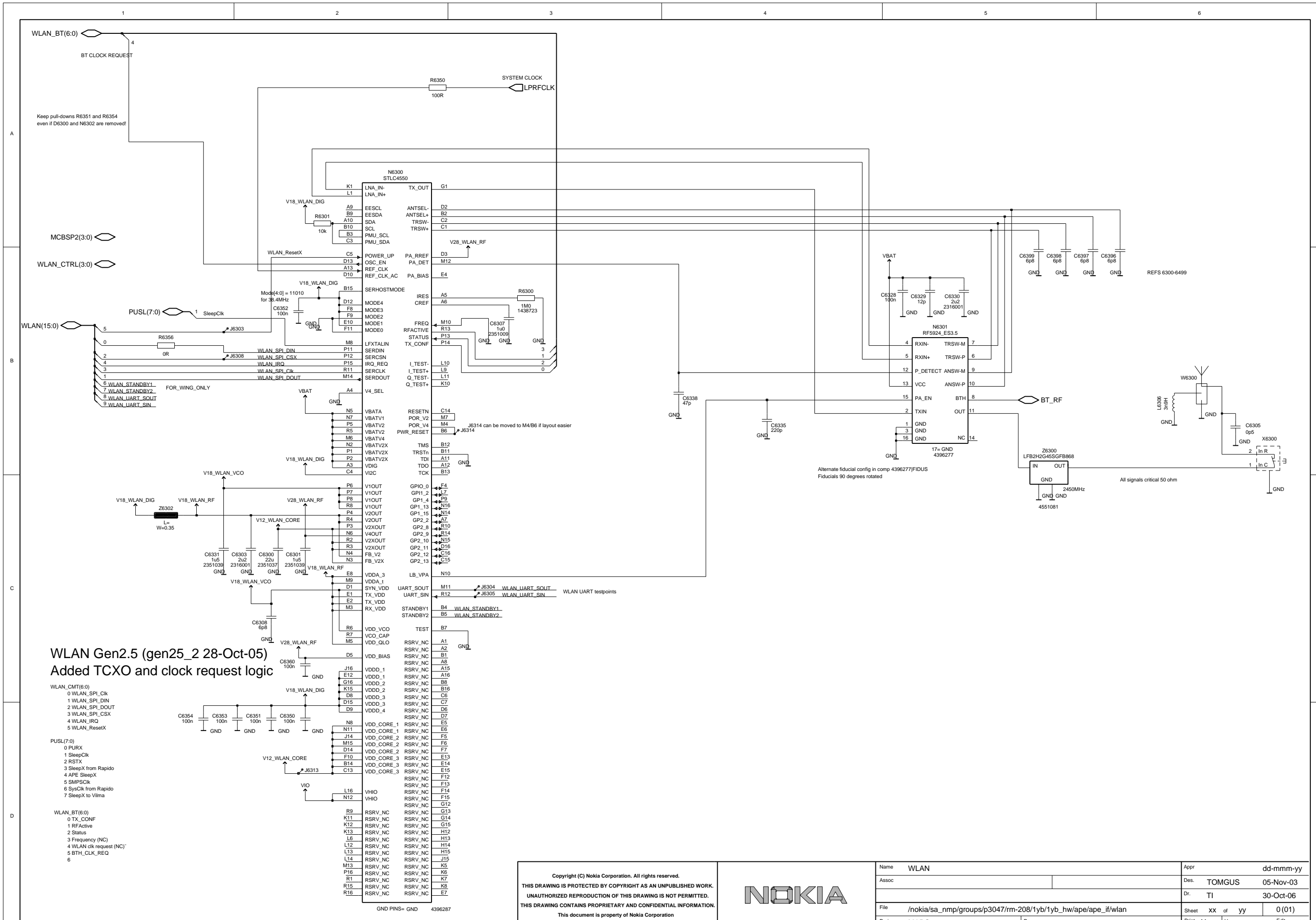

WLAN Gen2.5 (gen25_2 28-Oct-05)
Added TCXO and clock request logic

- WLAN_CMT(6:0)
 - 0 WLAN_SPI_Clk
 - 1 WLAN_SPI_DIN
 - 2 WLAN_SPI_DOUT
 - 3 WLAN_SPI_CSX
 - 4 WLAN_IRQ
 - 5 WLAN_ResetX
- PUSL(7:0)
 - 0 PURX
 - 1 SleepCk
 - 2 RSTX
 - 3 SleepX from Rapido
 - 4 APE SleepX
 - 5 SMPSCk
 - 6 SysCk from Rapido
 - 7 SleepX to Vima
- WLAN_BT(6:0)
 - 0 TX_CONF
 - 1 RFActive
 - 2 Status
 - 3 Frequency (NC)
 - 4 WLAN clk request (NC)
 - 5 BTH_CLK_REQ
 - 6

Copyright (C) Nokia Corporation. All rights reserved.
 THIS DRAWING IS PROTECTED BY COPYRIGHT AS AN UNPUBLISHED WORK.
 UNAUTHORIZED REPRODUCTION OF THIS DRAWING IS NOT PERMITTED.
 THIS DRAWING CONTAINS PROPRIETARY AND CONFIDENTIAL INFORMATION.
 This document is property of Nokia Corporation



| | | | |
|-------|--|-------|--------------------|
| Name | WLAN | Appr | dd-mmm-yy |
| Assoc | | Des. | TOMGUS 05-Nov-03 |
| | | Dr. | TI 30-Oct-06 |
| File | /nokia/sa_nmp/groups/p3047/rm-208/1yb/1yb_hw/ape/ape_if/wlan | | |
| Proj | MARS | Sheet | xx of yy 0(01) |
| | | Print | Yes v. 0.0 Edit 41 |

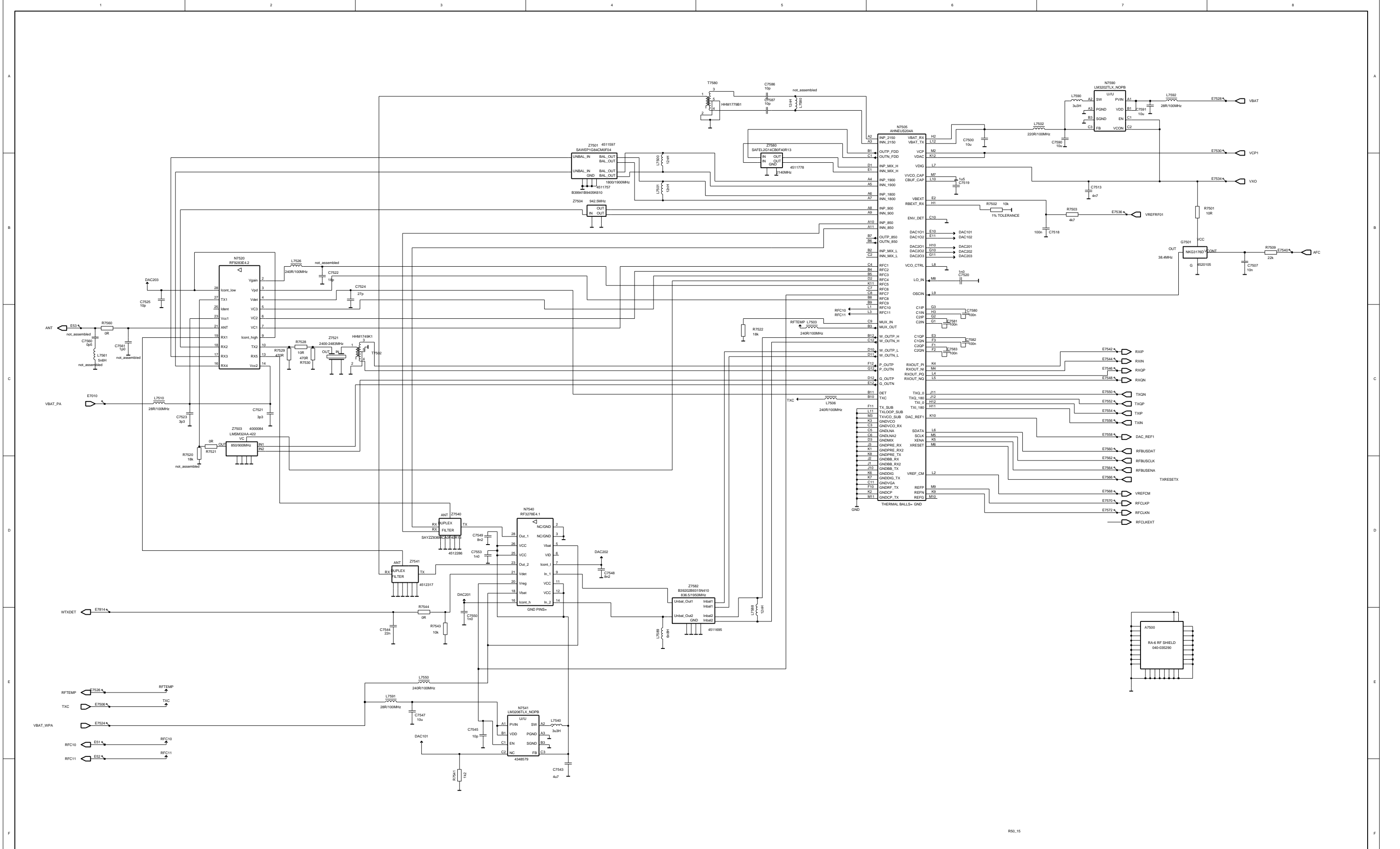

R50_15

| | | | | | | | |
|---|--|---|--|-----------------|--|----------------|--|
| Copyright (C) Nokia Corporation. All rights reserved. THIS DRAWING IS PROTECTED BY COPYRIGHT AS AN UNPUBLISHED WORK. UNAUTHORIZED REPRODUCTION OF THIS DRAWING IS NOT PERMITTED. THIS DRAWING CONTAINS PROPRIETARY AND CONFIDENTIAL INFORMATION. This document is property of Nokia Corporation | |  | | Name r50_engine | | Appr dd-mmm-yy | |
| Assoc r50 | | | | Des. Palomaa | | 22-Jun-05 | |
| File /nokia/sa_nmp/groups/p3047/m-208/1yb/1yb_07/RF5 | | Dr. TI | | 21-Dec-06 | | Sheet xx of yy | |
| Proj Rtsa 5.0 | | Dwg. | | V. 0.0 | | Edt 2 | |

Mutant for Xtra ground tuning to cover Qband GSM + EU WCDMA

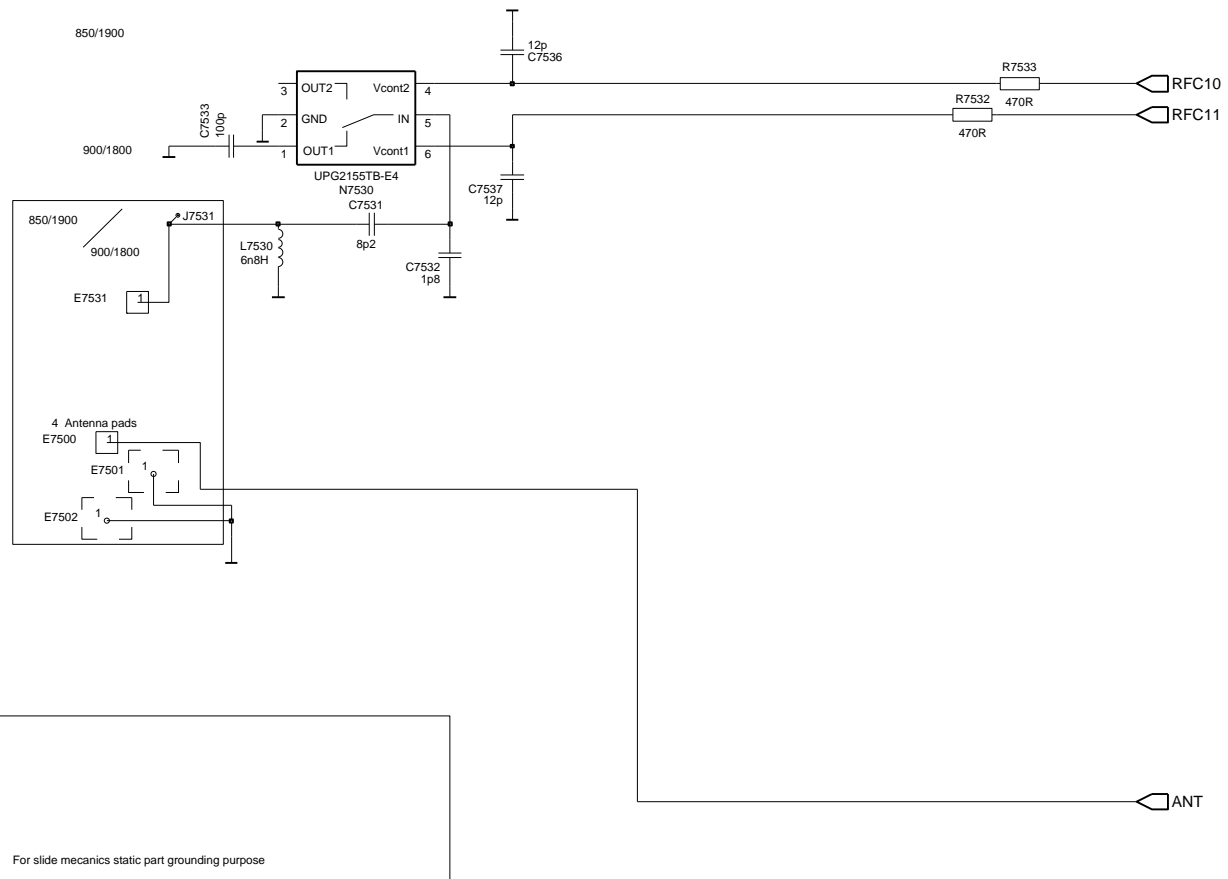

Copyright (C) Nokia Corporation. All rights reserved.
 THIS DRAWING IS PROTECTED BY COPYRIGHT AS AN UNPUBLISHED WORK.
 UNAUTHORIZED REPRODUCTION OF THIS DRAWING IS NOT PERMITTED.
 THIS DRAWING CONTAINS PROPRIETARY AND CONFIDENTIAL INFORMATION.
 This document is property of Nokia Corporation



| | | | |
|-------|---|-------|-------------------|
| Name | Afrodite antenna interface | Appr | dd-mmm-yy |
| Assoc | Mutant | Des. | T1 30-Jan-06 |
| | | Dr. | T1 21-Dec-06 |
| File | /nokia/sa_nmp/groups/p3047/rm-208/1yb/1yb_07/ant_band | Sheet | xx of yy 0 (01) |
| Proj | P3047 Afrodite | Print | Yes v. 0.0 Edit 2 |

