



Redking Video Camera Stabilizer (FLCM-RK)

Instruction Manual

FLYCAM

At Flycam, our goal is to ensure 100% Customer Satisfaction in all that we do.

We back our sales with a 1 year warranty from the date of purchase and work hard to resolve any problems in the unlikely event one should arise.

With our commitment to continuous improvement and your Feedback, building on our reputation of providing affordable, quality products is
PRIORITY #1.

Table of Contents

Subject	Page
Foreword	3
Introduction	4
Safety Hints	5
Assembling	6-7
Warranty	15

■ Welcome To Flycam!

Dear Client,

On behalf of all the people that work so hard to provide you with the most up-to-date, flexible and cost-efficient production gear, we would like to welcome you into the Flycam family.

By purchasing your Redking Video Camera Stabilizer, you have just joined a host of designers, engineers, machinists, assembly, customer service and office staff that take great pride in all that they do. Our mantra of continuous improvement has been the guiding principle of how we conduct our business since day one.

Once you have the opportunity to experience your new Redking Video Camera Stabilizer, we hope you will agree that we craft quality products at a competitive price. Products designed to meet and exceed the standards of today's real production world.

Standards set by our valued clients and standards we strive to maintain.

With Best Wishes,

Flycam Team

■ Introduction

Flycam introduces its professional and rugged Redking handheld video stabilizer; designed for film and video cameras. Redking works so well that it allows you to shoot incredibly smooth and graceful shots even while going to extremes like running up and down stairs or traveling over rugged terrain. And when it comes to normal shooting, like walking or moving the camera slowly around someone, the results are equally magical. All you need is your imagination, and you are ready to portray it with our state-of-art handheld camera stabilizer.

■ What's In The Box

Please inspect the contents of your shipped package to ensure you have received all that is pictured and listed below.

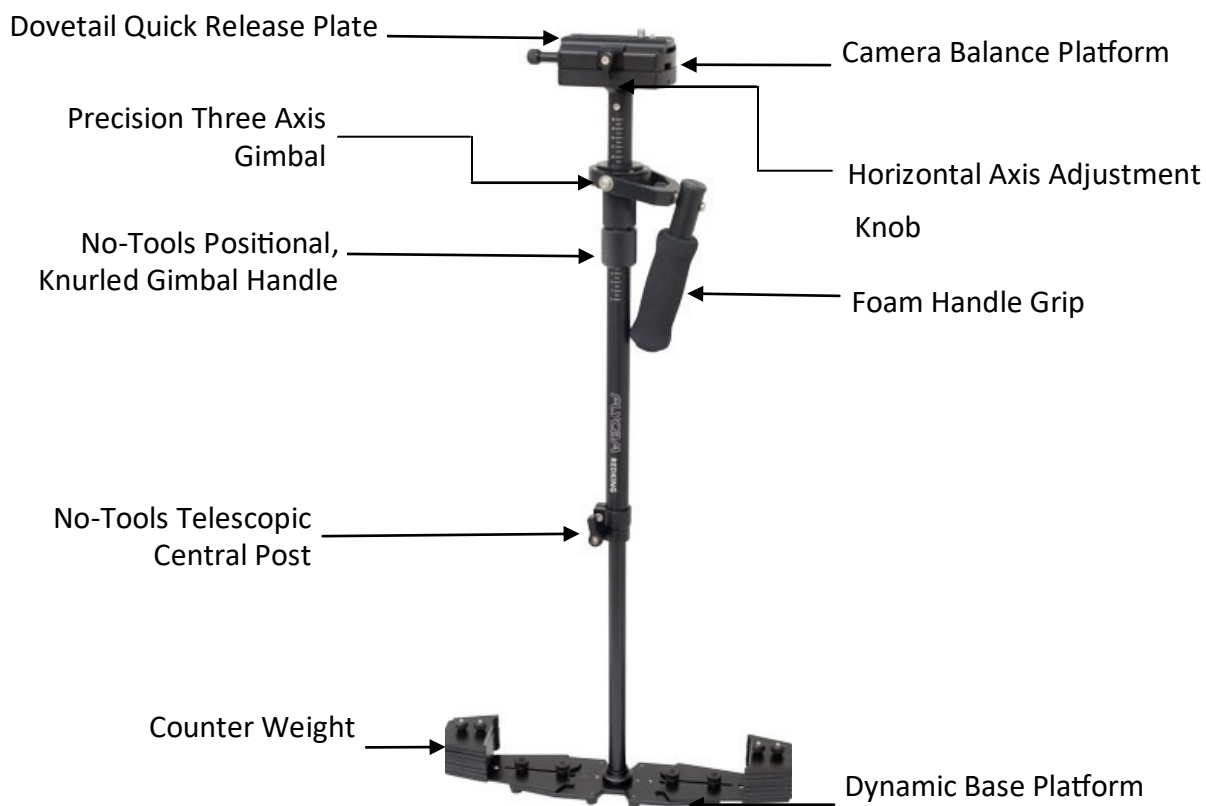

Storage Bag



Safety Hints

ATTENTION: PLEASE READ THIS BEFORE USING TO PREVENT SERIOUS DAMAGE TO THE GEAR!

BE HIGHLY VIGILANT OF SURROUNDINGS

Check the area you will be shooting in, before shooting. Make sure your path is clear. Look for obstacles and note anything you might run into or trip over. Extra care is also necessary when tackling stairs and other kinds of uneven ground.

ALWAYS WEAR PROTECTIVE GEAR

If you intend to shoot while moving fast or while traversing uneven terrain, do not hesitate to wear protective gear as knee or elbow pads, or a helmet.

DO NOT SHOOT IN UNSAFE CONDITIONS

Avoid situations where one commonly falls like skis, skates or running in muddy fields.

ADULT SUPERVISION IS RECOMMENDED

Minors using this product should have adult supervision.

FOLLOWING THESE GUIDELINES WILL PROVIDE BETTER SHOTS AND TROUBLE-FREE OPERATION.

SHOULD YOU NEED ADDITIONAL INFORMATION, TECHNICAL ASSISTANCE IS AVAILABLE 'ONLINE' BY CONTACTING YOUR SALES REPRESENTATIVE.

■ Assembling

- A threaded stud is located in the center of Base Platform for attaching Central Post. Securely tighten the adjustment knob on telescoping clamp by rotating it clockwise.

NOTE: *The adjustment knob should only be tightened by hand. Do not over-tighten it as it could cause thread stripping.*



- Loosen allen bolts at the bottom of Camera Plate, align its holes with the top of Central Post & re-tighten them securing the plate to post.



- Attach the quick release plate to the camera base. Slide the release lever to insert the camera set up into quick release adapter. Return the lever to its original locked position.



- Horizontal adjustment on the base platform is made by loosening the retaining screws and moving the mounted cups closer to or further away from the stalk and then retightening. You will probably need to adjust and re adjust the horizontal position to achieve optimum performance.



- Secure the counter weight plate by using the black thumb nuts to prevent weight movement.

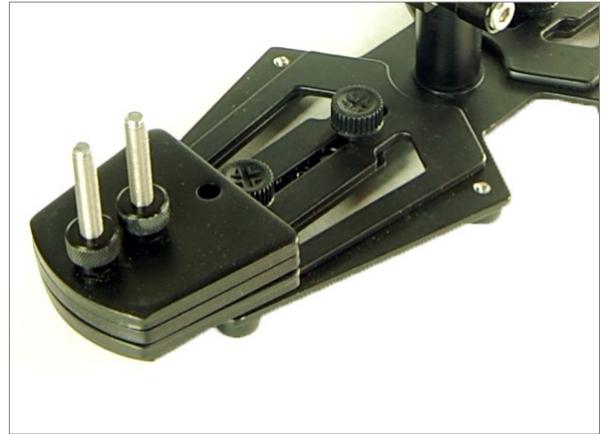

NOTE: Remember to leave at least 1" of the telescoping post showing below the telescoping clamp.

- The easiest way to correctly align the parts is loosen the screw on the top part of telescoping clamp, using allen wrench, until you can rotate the parts so they are correctly aligned. Then simply re-tighten the screw.



- All the parts of your Redking Stabilizer will be correctly aligned, as shown.

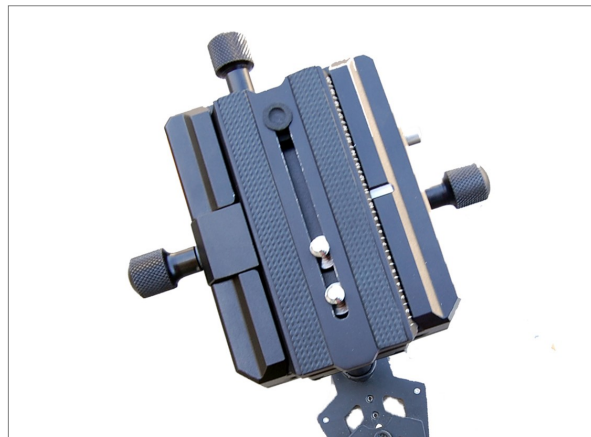

■ Balancing the Horizontal Axis—Static Balancing

Fine tune side-to-side or fore/aft balance with the knobs on camera platform. Hold the sled absolutely vertical as you adjust. Turn the adjustment knobs with your other hand (or use the stage motor transmitter) until you feel no pressure on your operating hand and the sled will be in static balance.

- Now that your Flycam Redking Camera Stabilizer is setup and assembled properly, you can test and setup the horizontal balance of the system. If the Stabilizer is horizontally balanced correctly, then camera will remain level and central post will remain vertical during operation, unless you intentionally position stabilizer otherwise or release any pan, tilt or roll pressure on central post.



When testing for correct horizontal balance you need to make sure that you pick up your Stabilizer from a flat surface (for e.g. a table) and that you let the Stabilizer hang freely as you hold it.

Note: *If you do not have enough counter weight on the base platform at this time, the entire Stabilizer will flip completely upside down. If this happens add more counter weight below until during this test the Stabilizer remains up.*

- If Stabilizer tilts to the front, then you will have to turn Adjustment Knob counter clockwise. If it still tilts to front, then move dovetail quick release plate more towards back by turning knob. If Stabilizer tilts to the back, then move dovetail quick release plate towards front by turning the knob clockwise. Always secure dovetail quick release plate lock after any adjustments. If you cannot get the front to back axis balanced with this method, then try re-mounting your camera to a different position on dovetail quick release plate.



■ Balancing the Vertical Axis – Dynamic Balancing

Dynamic balance is extremely important for precise operation. For each arrangement of camera, monitor position, post length, accessories, etc., there are many possibilities for statically balancing the Steadicam. However, for each arrangement, there is only one combination that also balances the sled dynamically.

Dynamic balance can easily be achieved by trial and error method.

In all cases, when a sled is in dynamic balance, the camera's center of gravity will be towards rear of the center line of central post. This rule gives you some point to begin balancing the Steadicam.

Now that your Stabilizer is horizontally balanced, its vertical axis can be tested and properly balanced. If the Stabilizer is vertically balanced correctly, then camera will remain level and central post will remain vertical during operation, unless you intentionally position stabilizer otherwise. If it is not balanced properly, then it will swing about and pendulums when you walk, run, or turn.

Slightly bottom heavy, it will be both stable and easier to control.

Check the vertical balance by using this drop time test.

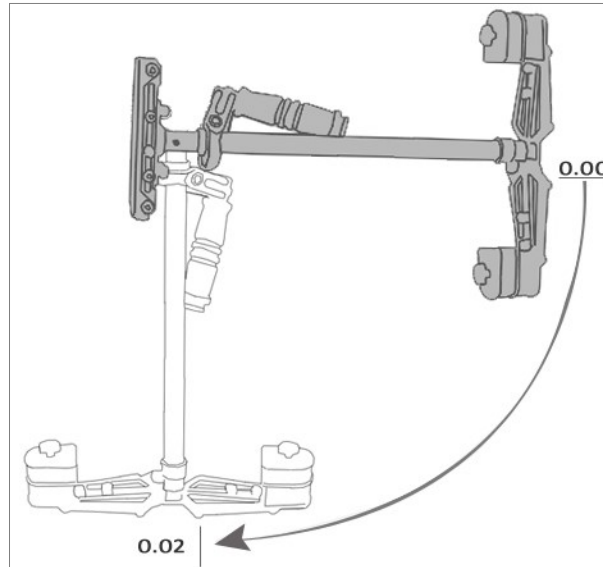

- Make sure that everything is tight.
- Grasp Central Post near the base and move it from vertical to horizontal.
- Hold it there. Be sure that it will not hit the stand when you drop it. Keep your free hand to catch the central post when it drops.
- Count how many seconds it takes to fall to vertical. Try using a stopwatch.
- If the drop time is less than 2 seconds, it is too bottom heavy. You need to move the bottom mass closer to post.
- If the drop time is more than 2 seconds, it is top heavy.

A DROP TIME OF 2 - 2.5 SECONDS IS PREFERRED.

***Note:** Recheck the balance by looking at sled. If necessary, use side screws and bottom plate screws to make required adjustments.*

Holding Your FLYCAM stabilizer

When handling your Redking Video Camera Stabilizer one hand holds onto the handle while the other is used to gently guide the camera in the direction you wish to shoot and frame the shot. For normal shooting, hold the handle in the middle.

- For shots that require framing the camera up, down or sideways, hold the handle firmly at the bottom.

NOTE: Make sure that your “GUIDING HAND” and “HOLDING HAND” do not touch either the bearing assembly or the “YOKE” during shooting. For unconventional shots, like ones that require aiming the camera either straight up or down, or sideways, hold onto the Stabilizer on the lower part of the post, or down near the weight. This will allow your “GUIDING HAND” to have a greater degree of control over the Stabilizer while shooting erratic shots.



Low-Mode Operation

When operating Redking Stabilizer in Low-Mode, you will not be able to put your eye right up to the eyecup on viewfinder. For doing so will cause the unit to be restricted in its ability to stabilize and eliminate camera shake. You can either use camera’s built-in LCD Monitor or attach an external LCD Monitor (**Not Included**) directly to the base platform of stabilizer. A 1/4”-20 monitor mounting hole is located at both the front and back edges of Base Platform.



NOTE: You can also attach an external LCD Monitor (**Not Included**) to the accessory shoe on top of your Camcorder. We believe that better results are obtained when you attach monitor to Flycam Redking Stabilizer’s base, because this way you have to look slightly down to see the monitor and so, your feet are more visible to your peripheral vision. This makes negotiating obstacles with the Stabilizer safer.



Balancing Review

Proper system balance can only be achieved once your camera is set up with appropriate accessories ready for shooting. This means batteries, lenses, media cards, LCD viewfinder/monitor, quick release plate, on-cam lights, and all the gear you will use for your recording session.

- Remove top plate of FLYCAM and line up your camera so that its center of gravity is as close to the center of the plate as possible (basically hold the camera in your hand until it feels balanced both left and right as well as forward and back).
- Find hole in the plate that is as close to threaded tripod mount on your camera as possible (while you are still holding your camera's center of gravity to the center of the plate). Attach your camera (or quick release mount if you have one). Tighten it down so it won't accidentally rotate.
- Re-attach top plate to the FLYCAM . Center it, but don't worry about getting it absolutely perfect yet.
- Remove most of the weights from Base Platform, but leave one on each side.
- Insert the center post as far as it will go and tighten so it won't slide out.
- Hold the handle normally and turn the FLYCAM so that it is horizontal to the ground. Let go of the stalk while keeping a firm grip on the handle and count how long it takes to return to vertical again. You should be able to count a good, "One-one thousand, two-one thousand", before it rights itself. With only two little weights it might take considerably longer.
- Add one pair of weights at a time and repeat the "horizontal to vertical" test until it falls at the correct rate. It will probably not be perfect.
- You'll get one that's too slow and then you'll add a pair and it will fall too fast. When that happens, take off the last pair of weights that you added.
- Tighten down the weights so they don't slide around.

- To get count perfect, slightly lower the center post that attaches the Base Platform with the weights until you get the "one-one thousand, two one thousand" count to the vertical position.
- Fine-tune the left-right, forward-backward balance. You will have to go back and forth between the two directions to get the balance just right. Loosen the screw sets that allow the sled to move left and right. Adjust the top plate so that it is centered and tighten down the screws like you would a tire slowly and alternating side to side.
- Repeat for "forward-backward" balancing.
- Check to see if your camera is sitting level. If not, repeat the necessary steps until it does.
- Practice walking movements ensuring your body motion is not transmitted to your hands and then the FLYCAM and camera.

Maintenance

Bearing Maintenance

The main Bearing on your Flycam Handheld Stabilizer is attached to the Central Post about two inches from the top. It is of metal construction and partially enclosed by the Bearing assembly.

If after a period of time your bearings don't turn smoothly, lubricate with a minimum of light machine oil. Light lubricating oil can also be used on the Yoke and Handle Bearings.

Be sure to keep oil away from your camera, & clean up any over spill.

Cleaning

Do not use solvents or harsh cleaners of any kind on your Flycam Hand held stabilizer. If the unit becomes dirty, use a damp soft cloth or sponge and a mild detergent to gently clean external parts.

Storage

Should you need to store your Flycam Hand held stabilizer for a long period of time then place the unit upright in a dry or low to normal humidity area whenever possible. If you are unable to find this kind of environment then we suggest you store the unit in an airtight plastic container or bag. Standing the unit upright is preferred as it alleviates stress on the system.

NOTE: *Flycam Redking Video Camera Stabilizer doesn't work under water, nor is it waterproof. Avoid direct exposure to rain, water spray or any harsh environment. The bearings are not sand proof. Avoid getting dirt or sand in them.*

Practice makes perfect - Walking the line

Practice this simple exercise to master your Flycam Redking stabilizer with professional results. Using masking or gaffers tape, create a cross mark on a flat and even wall. The mark becomes your framing center. On the floor leading up to the cross mark, lay a straight tape line of about 20 feet. Practice walking the line, while keeping the cross mark center framed and in focus. With a bit of effort, dramatic fluid like movements will become second nature and provide production value to all your set ups.

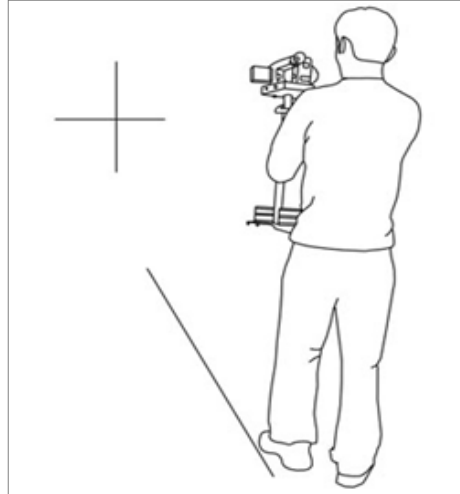

YOUR FLYCAM REDKING VIDEO CAMERA STABILIZER

ALL DRESSED UP AND READY TO GO!



(SHOWN WITH OPTIONAL ACCESSORIES)

WARRANTY

We offer a one year warranty for our products from the date of purchase.

We will repair or replace your product, free of charge, in the event of a defect in materials or craftsmanship obtained during normal use or handling based on the user manual. Please note that we will not cover any shipping costs for returning the product to us. If any VAT or import duties are applied to the return, we will also charge these costs to the customer.

The warranty does not include, by the way of example, damage caused by products that we do not supply or from mishandling in transit, accident, misuse, neglect, lack of care of the product , or service by anyone other than our company.

We are not liable for incidental or consequential damages resulting from the use of the unit or occurring due to any breach of this warranty.

Replacement parts of the product will be provided at nominal cost (covering the cost price of the replacement parts only) to the customers after the Warranty Period has expired. We will cover

the complete cost of sending replacement parts within the warranty period. After that, Nominal cost of the product & Actual shipping cost will be charged.

Do not send the unit to us without first getting a response and getting the approval to send back the item.

In case of any kind of dissatisfaction, we urge you to Contact us immediately and we shall do our Best to help you out. For any other assistance you can reach us via email.

For any other assistance you can reach us via email.