

SERVICE MANUAL

16-CL

ELMO CO., LTD.

Nagoya, Japan

I N D E X

I. DISASSEMBLY & ASSEMBLY

	Page
A. COVER	1
B. TAKE-UP REEL ARM	3
C. FEED REEL ARM	5
D. REWINDING MECHANISM	7
E. MACHINE FRAME - LINK	9
F. MACHINE FRAME - LEVER SPROCKET SHOE	11
G. MACHINE FRAME - LOOP RESTORER	13
H. MACHINE FRAME - SPROCKET	15
I. MACHINE FRAME - TILTING	17
J. MACHINE FRAME - UNIVERSAL JOINT	17
K. MAIN SWITCH	19
L. CLAW SECTION	21
M. PROJECTION LENS	25
N. PROJECTION LAMP	25
O. MOTOR	27
P. TRANSFORMER	29
Q. SOUND BASE PLATE	31
R. AMPLIFIER	35

II. ADJUSTMENT

S. TAKE-UP REEL ARM	37
T. REWINDING MECHANISM	38
U. LEVER	43
V. LOOP RESTORER	45
W. CLAW SECTION	48
X. SOUND BASE PLATE	51

III. TROUBLE SHOOTING

TAKE-UP & FEED REEL ARMS	55
CLAW SECTION & MACHINE FRAME	56
PROJECTION LAMP & LENS	58
MOTOR & TRANSFORMER	59
SOUND	60

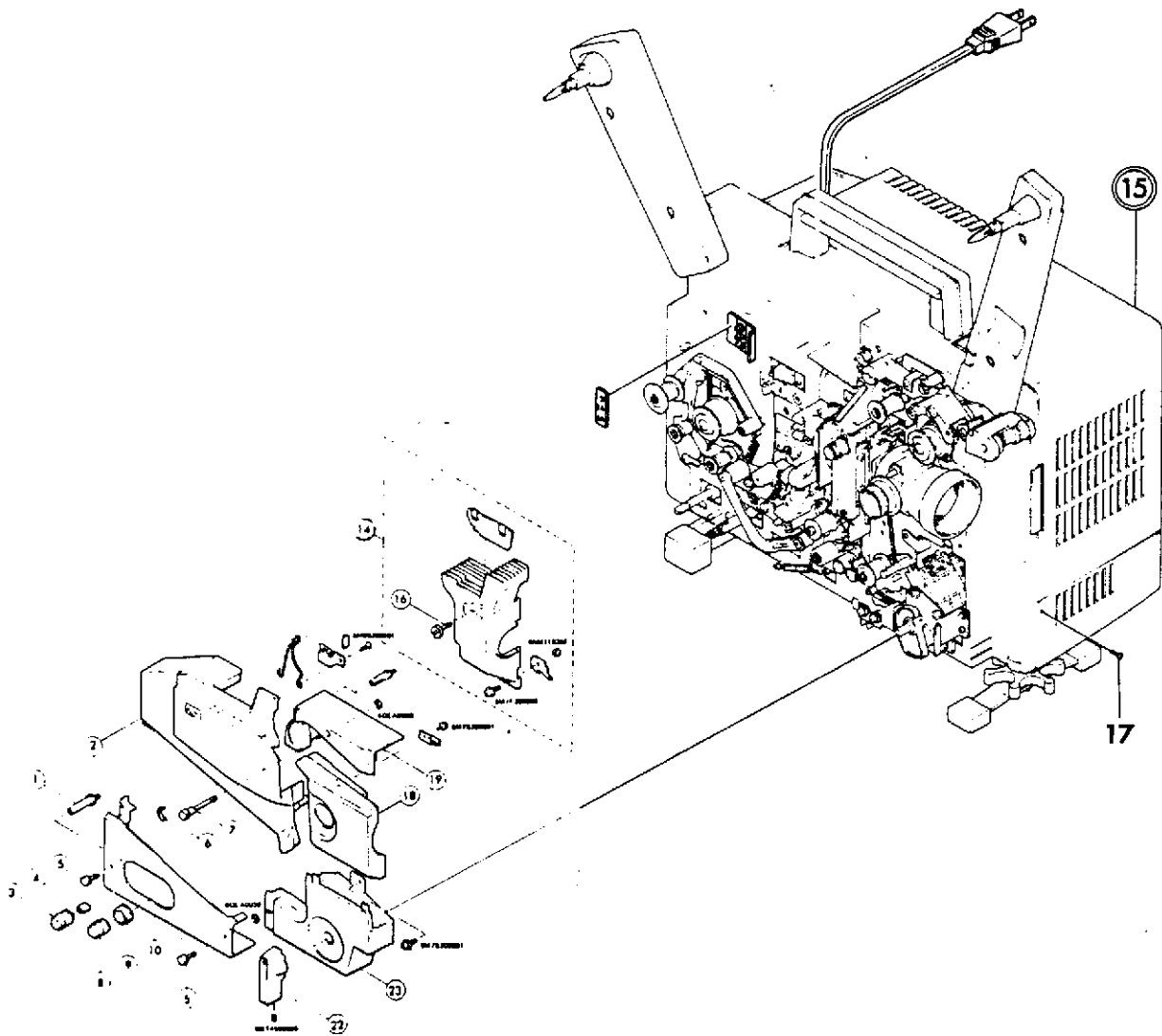

Fig. 1

Illustration No.	Parts No.	Parts Name
2	4P10322	Front cover 3
3	P412228	Knob M-0 switch
5	P414770	Screw front cover 12
7	P414741	Screw front cover 4
8	P412230	Knob amplifier
9	P412229	Knob amplifier
10	4P20732	Front cover 12
14	4P8CL0030	Lamp house assy.
15	4P8CL0129	Rear cover assy.
16	4P55646	Screw (2) lamp house
17	6M60300605	Screw truss M630-6
18	4P20570	Front cover 2
19	4P20571B	Front cover 4
22	P412227	Knob main
23	4P20731	Front cover 11

I. DISASSEMBLY & ASSEMBLY

A. COVERS

1. Disassembly

- (1) Pull out Fig. 1-2 & 18 by hand.
- (2) Remove Fig. 1-19 by detaching Fig. 1-7.
- (3) Remove Fig. 1-10 by removing Fig. 1-3, 8, 9, 5x2.
- (4) Remove Fig. 1-23 by removing Fig. 1-22.
- (5) Remove Fig. 1-15 by removing Fig. 1-17x4.
- (6) Remove Fig. 1-14 by removing Fig. 1-16.

2. Assembly

Follow the reverse way of the above steps.

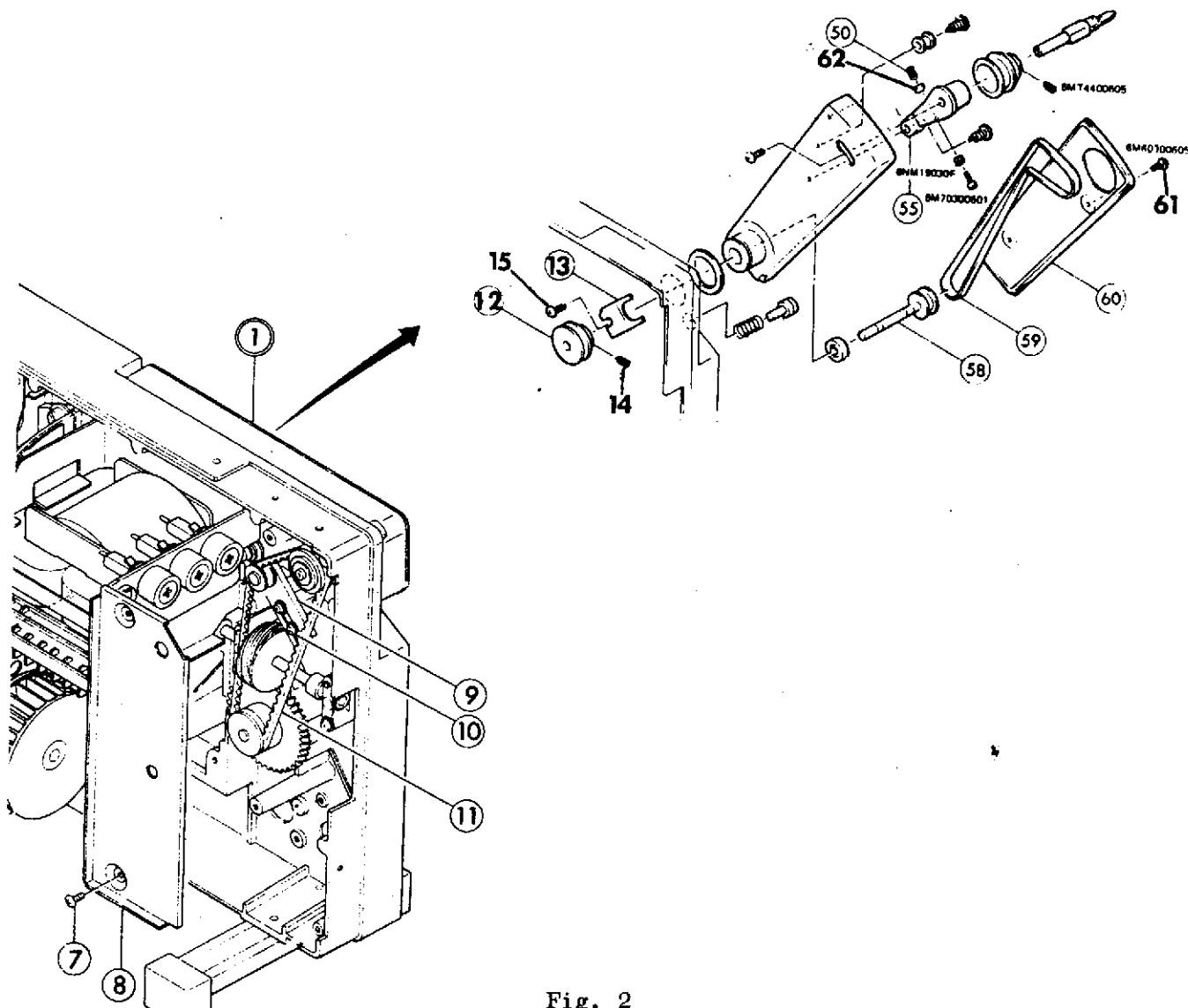

Fig. 2

Illustration No.	Parts No.	Parts Name
1	4P8CL0007	Take-up arm assy.
7	6M6300605	Screw truss M630-6
8	P412190	Rear cover plate
9	P412127	V belt guide roller assy.
10	6M7B30081	Screw sems-B M730-8
11	P412203	V belt take-up
12	P412170	V pulley (2) take-up
13	P412156	Lock spring boss arm
14	6MT4400605	Set screw hexagon M40-6
15	6M7B401001	Screw sems-B M740-10
50	4P55578	Brake spring take-up
55	P412126	Lever arm take-up assy.
58	P412441	Shaft take-up assy.
59	P412289	Belt take-up arm
60	4P20576	Arm (2) take-up
61	6M60300605	Screw truss M630-6

B. TAKE-UP REEL ARM

1. Disassembly

- (1) Remove Fig. 2-60 by detaching Fig. 2-61x2.
- (2) Remove Fig. 2-59 by pushing up Fig. 2-55.
- (3) Remove Fig. 2-1 in the following order.
 1. Remove Fig. 1-15.
 2. Remove Fig. 2-8 by removing Fig. 2-7x2.
 3. Remove Fig. 2-11 by loosening Fig. 2-10x2.
 4. Remove Fig. 2-13 by loosening Fig. 2-15.
 5. Remove Fig. 2-12 by removing Fig. 2-14.

2. Assembly

Follow the reverse way of the above steps, paying attention to the following points.

- (1) Adjust the tension of Fig. 2-11 by moving Fig. 2-9 (tight).
- (2) Check the tension of Fig. 2-59 and adjust it by adjusting the tension of Fig. 2-50 by Fig. 2-62.

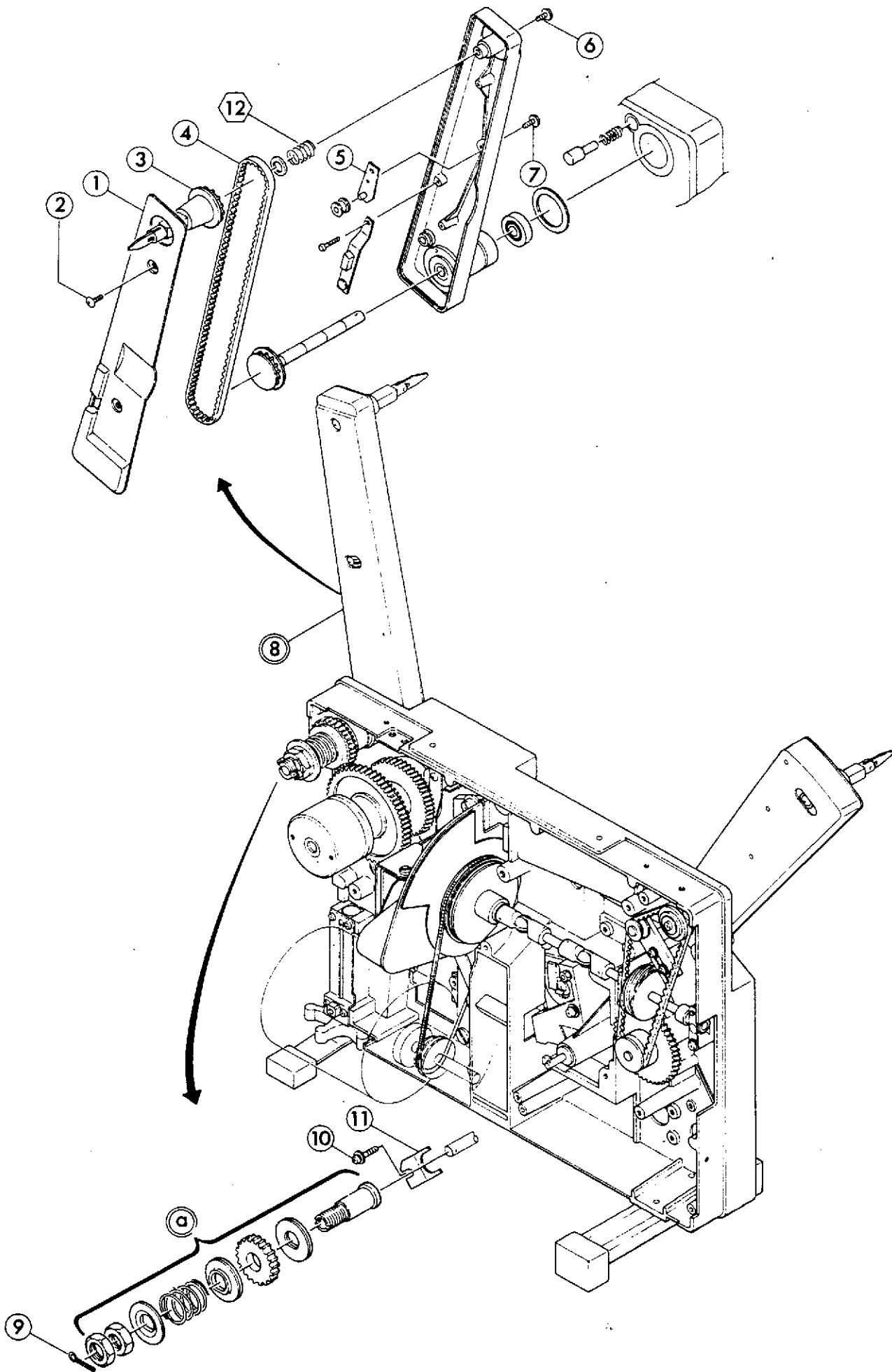

Fig. 3

C. FEED REEL ARM

1. Disassembly

- (1) Remove Fig. 1-19 and set Fig. 1-22 at "●" position.
- (2) Remove Fig. 3-1 by detaching Fig. 3-2x2.
- (3) Remove Fig. 3-4 by detaching Fig. 3-6, 3.
- (4) Remove Fig. 3-8 in the following order:
 - * Remove Fig. 1-15 and set Fig. 1-22 at "●" position.
 - * Remove (a) in Fig. 3 together by detaching Fig. 3-9.
 - * Remove Fig. 3-11 by detaching Fig. 3-10.

2. Assembly

Follow the reverse way of the above steps, paying attention to the following point.

- (1) Check the tension of Fig. 3-4, and adjust it by changing the position of Fig. 3-5, if necessary.
 - * Loaded film should not hang down beyond the projection lens during projection and when projection is stopped.
 - * The belt should not slip during rewinding.

Illustration No.	Parts No.	Parts Name	
1	4P20575	アーム(2)巻返	Arm (2) rewind
2	6M60300605	トラス小ネジ M630-6	Screw truss M630-6
3	4P8CL0039	巻返角棒シャフト組立品	Rewind square shaft assy
4	P412321	シンクロベルト206XL016G	Synchro belt (206XL016G)
5	P412384	組立アームガイドローラ巻返	Guide roller rewind assy
6	4P47107	ネジランソケットホルダ	Lamp socket holder screw
7	6M60300601	トラス小ネジ M630-4	Screw truss M630-6
8	4P8CL0004	巻返アーム組立品	Rewind arm assy
9	6J1251801	ワリピン2.5-18	Split pin 2.5-18
10	6M60400801	ナベ小ネジセムS B M740-10	Screw truss M640-8
11	P412156	ロックバネボスアーム	Lock spring boss arm
12	4P55623	制動バネ巻返	Brake spring rewind

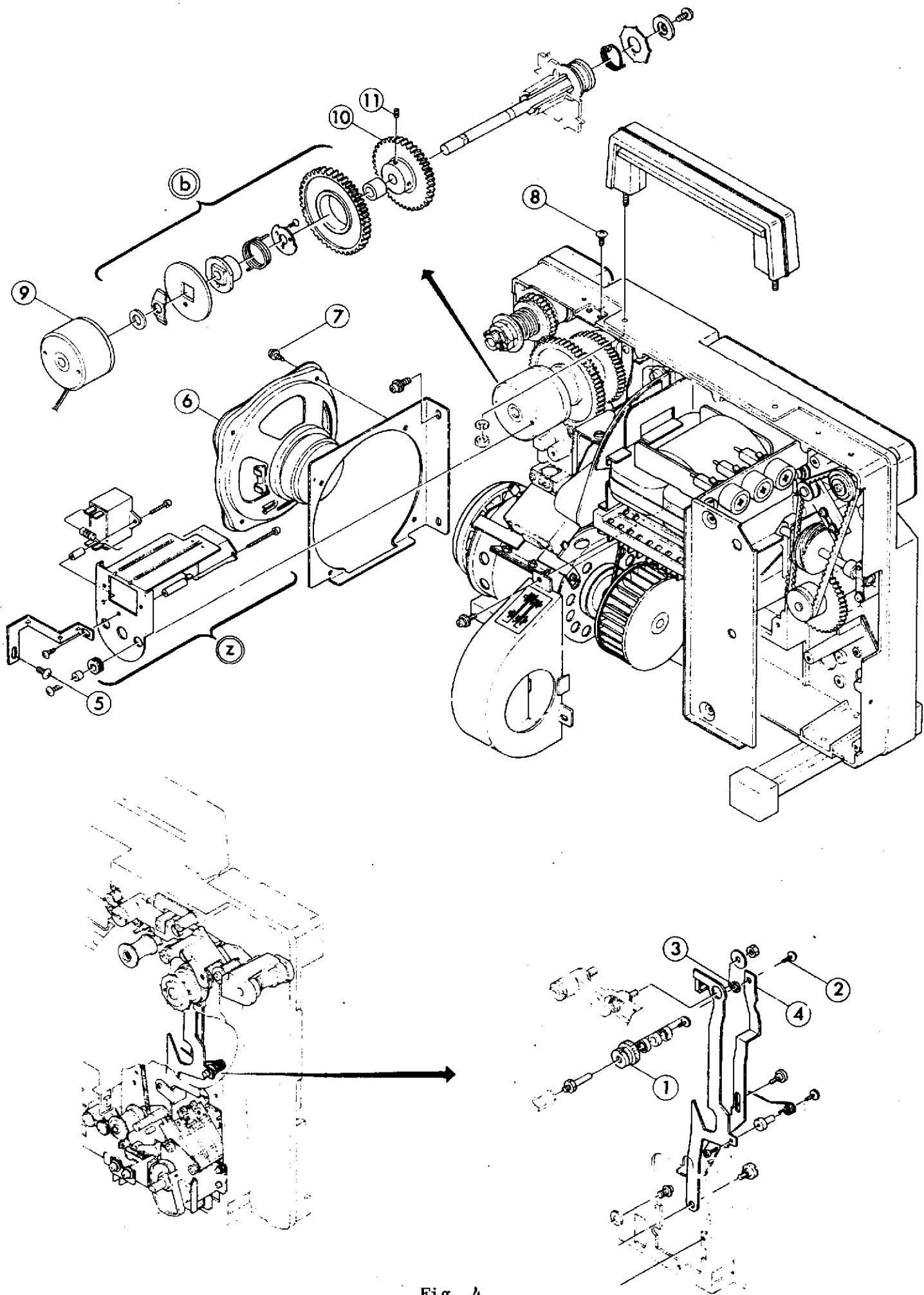

Fig. 4

D. REWINDING MECHANISM

1. Disassembly

- (1) Set Fig. 1-22 at "OFF" position.
- (2) Remove Fig. 4-9, (z) by detaching Fig. 4-8x2,5.
- (3) Remove Fig. 4-6 by detaching Fig. 4-7x4.
- (4) Remove Fig. 4-9 by loosening 2 rotor attaching screws of Fig. 4-9 and remove (b) in Fig. 4 together.
- (5) After Fig. 4-2,3 are detached, remove Fig. 4-10 by loosening Fig. 4-11x2.

2. Assembly

Follow the reverse way of the above steps, paying attention to the following points.

- (1) After Fig. 4-2,3 are attached, check the movement of Fig. 4-1,4, connecting the power cord to power source.
- (2) After the assembly is completed, adjust the gap between clutch plate and rotor of Fig. 4-9 and movement of clutch of Fig. 4-9. (Refer to T-2)
- (3) The terminal of Fig. 4-6 should be at the side of Fig. 1-15.
- (4) Fig. 4-9 should be always replaced as a unit.

Illustration No.	Parts No.	Parts Name	
1	P412237	摩擦車(2)ルーフセッタ	Friction wheel 2
2	6M60250601	トラス小ネジ M625-4	Screw truss M625-6
3	4P55616	間座摩擦車	Washer friction wheel
4	4P31849	リンク(1)ルーフセッタ	Link (1) loop setter
5	6M7B00601	トラス小ネジ M630-4	Screw sems M730-6
6	5V1024	スピーカ8Ω	Speaker
7	6M60400601	ナベ小ネジセムスB M740-8	Screw M740-6
8	6M60300601	トラス小ネジ M630-4	Screw truss M630-6
9	6Y49491003	電磁クラッチ	Magnet clutch (ZCF-10B)
10	P412270	ウォームギヤ(1)組立品	Worm gear (1) assy
11	6MT4400805	六角穴止メネジ M40-8	Set screw hexagon M40-8

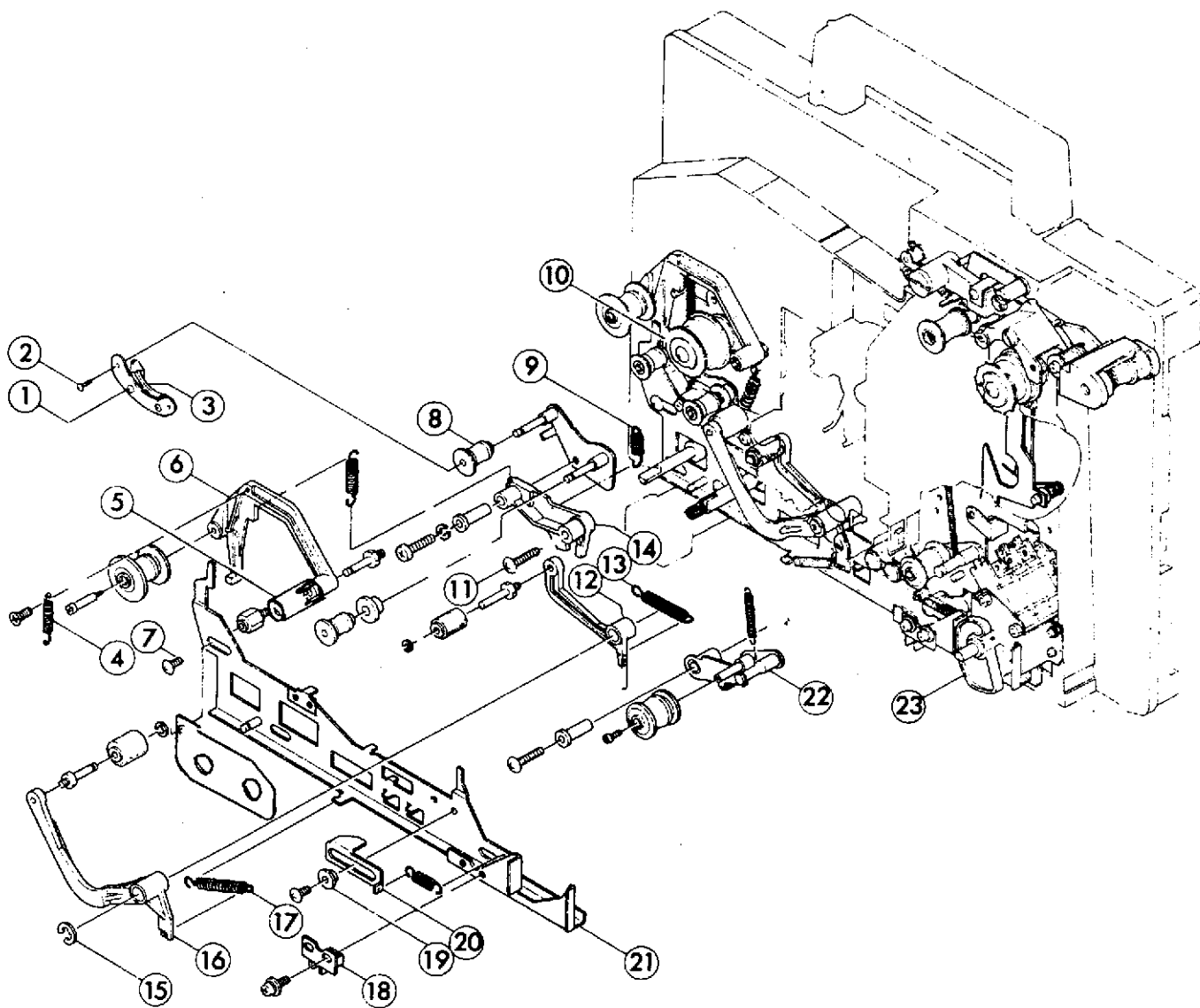

Fig. 5

Illustration No.	Parts No.	Parts Name	
1	6M60200501	トラス小ネジ M620-5	Screw truss M620-5
2	6M60200501	トラス小ネジ M620-5	Screw truss M620-5
3	P412367B	シュー第2スプロケット	Shoe second sprocket
4	4P55661	バネレバーガイドローラ(4)	Spring guide roller 4
5	P412935	ストッパ軸前カバー(3)	Stabilizer lever GR4
6	P412051C	レバーガイドローラ(4)	Lever guide roller 4
7	6M80300805	トラス小ネジ M640-6	Screw 830-5
8	P412221	ローラ第2スプロケット押エ	Roller second sprocket
9	4P55573	バネレバー(1)第2スプロケット押エ	Spring second sprocket
10	4P44463	16mmスプロケット	Sprocket
11	6M60402501	トラス小ネジ M640-20	Screw truss M640-25
12	P412057C	レバープレッシャローラ	Lever pressure roller
13	4P55551	バネプレッシャローラ	Spring pressure roller
14	P412059C	レバー(1)第2スプロケット押エ	Lever (1) second sprocket
15	6QE(A)0060	EリングER-6	E-ring ER-6

E. MACHINE FRAME - LINK

1. Disassembly

- (1) Set Fig. 1-22 at "●" position.
- (2) Remove Fig.1-2,10,23,18 and attach Fig.1-22.
- (3) Remove Fig. 5-6 by detaching Fig. 5-4,5.
- (4) Remove Fig. 5-14 by detaching Fig. 5-4,9,11.
- (5) Remove Fig. 5-16 by detaching Fig. 5-15,17.
- (6) Remove Fig. 5-21 by detaching Fig. 5-7x3.
- (7) Remove Fig. 5-12 by detaching Fig. 5-13.
- (8) Remove Fig. 5-8 by detaching Fig. 5-2x2.
Do not loose Fig. 5-1x2.

2. Assembly

Follow the reverse way of the above steps, paying attention to the following points.

- (1) After the assembly is completed, check the movement of levers which are interlocked with Fig. 5-21.
- (2) Adjust the position of Fig. 5-3 so that the space between Fig. 5-3 and 10 comes to the thickness of three laminated films.
- (3) When Fig. 5-18 is removed or replaced, check and adjust the related movement of Fig. 5-21,18 and 23 by moving Fig. 5-18.
(Refer to U-1)
- (4) When Fig. 5-20 is removed or replaced, check and adjust the related movement of Fig. 5-20 and 22 by turning Fig. 5-19x2.
(Refer to V-1)

16	P412058	レバー中間テンション	Lever middle tension
17	4P55608 B	バネ中間テンションローラ	Spring tension roller
18	P412166 B	ホルダリンク(3)	Holder link 3
19	4P55575	間座押エ板ガイドローラ(3)	Washer guide roller 3
20	P412206 B	押エ板レバーガイドローラ(3)	Plate guide roller 3
21	4P31836 C	連桿(1)	Link 1
22	P412179	レバー組立ガイドローラ(3)	Lever guide roller 3
23	P412173	カム連桿(1)	Cam link 1

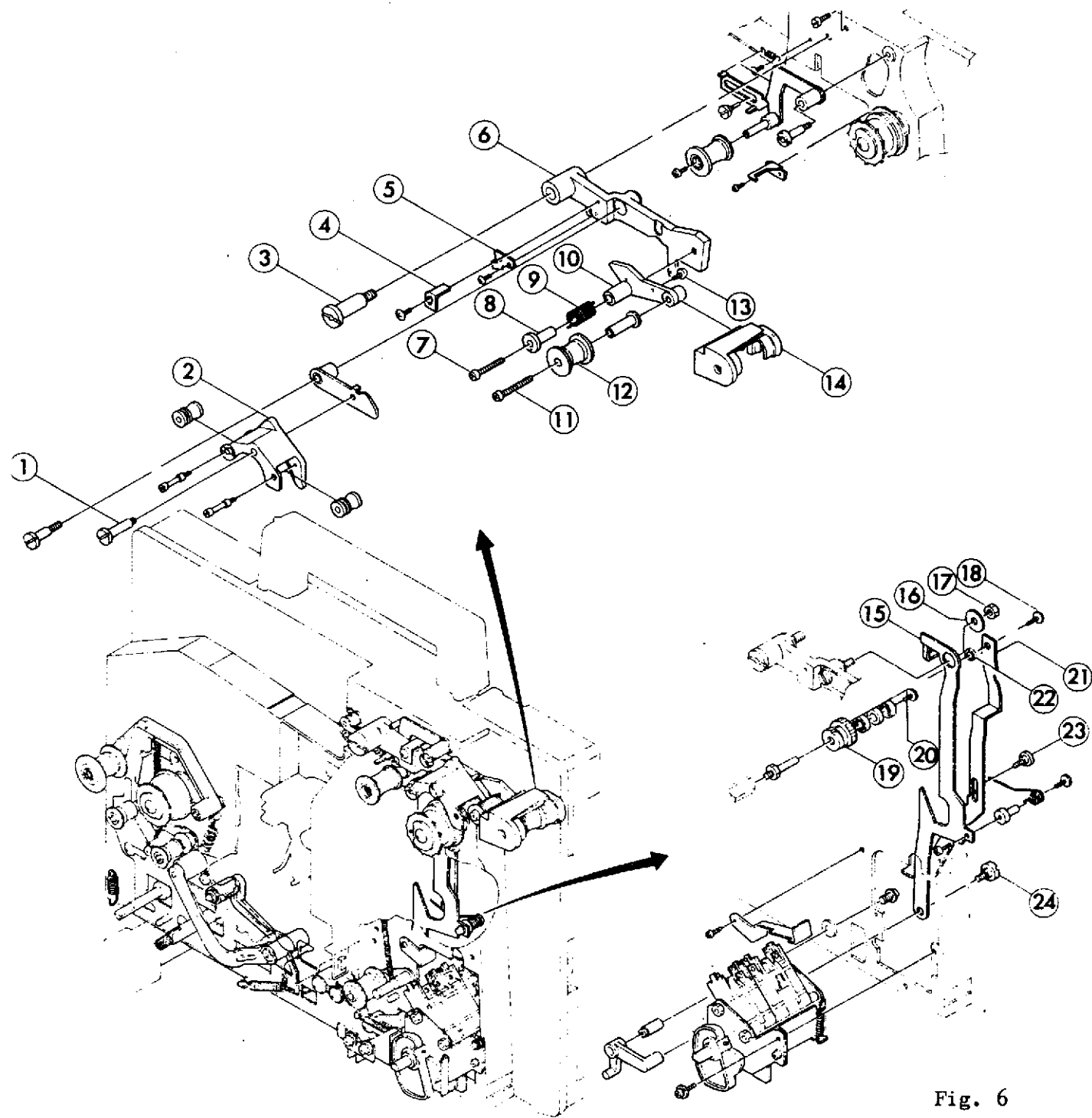

Fig. 6

Illustration No.	Parts No.	Parts Name	
1	4P55580	段付ネジ第1スプロケットシュー	Screw sprocket shoe
2	4P31838	シュー第1スプロケット	Shoe first sprocket
3	4P55579	段付ネジレバシュー	Screw lever shoe
4	P412344	押エ板レバガイドローラ(2)	Plate guide roller 2
5	P412216 B	ストッパガイドローラ(2)	Stopper guide roller 2
6	4P31827 B	レバースプロケットシュー	Lever sprocket shoe
7	6M70402501	ナベ小ネジ M740-25	Screw pan M740-25
8	4P55571	間座取付板ガイドローラ(1)	Washer holder roller 1
9	4P55583	バネ取付板ガイドローラ(1)	Spring holder roller 1
10	P412174	取付板ガイドローラ(1)	Holder guide roller 1
11	6M70402501	ナベ小ネジ M740-25	Screw pan M740-25
12	P412200	ガイドローラ(1)	Guide roller 1
13	6M6300605	トラス小ネジ M630-6	Screw truss M630-6

F. MACHINE FRAME - LEVER SPROCKET SHOE

1. Disassembly

- (1) Remove Fig.1-2,19,14,18,15.
- (2) Remove Fig. 6-12 by detaching Fig. 6-13,14,11.
- (3) Remove Fig. 6-10 by detaching Fig. 6-7.
- (4) Remove Fig. 6-2 by detaching Fig. 6-1.
- (5) Remove Fig. 6-6 by detaching Fig. 6-17,16,3.
- (6) Remove Fig. 6-15 in the following order:
 - * Remove Fig. 12-15.
 - * Remove Fig. 14-12.
 - * Remove Fig. 6-21 by detaching Fig. 6-18,22,20,19,23.
 - * Remove Fig. 6-15 by detaching Fig. 6-17,16,24.

2. Assembly

Follow the reverse way of the above steps, paying attention to the following points.

- (1) When Fig. 6-7 is loosened, turn Fig. 6-8,9 so that the tension on Fig. 6-10 may come to 50-80 gr., measuring the tension at the attaching position of Fig. 6-11 by the tension gauge. (Refer to U-1)
- (2) When Fig. 6-6 is removed or replaced, adjust the position of Fig. 6-4,5. (Refer to U-1)

14	4P31886	カバンガイドローラ(1)	Cover guide roller 1
15	4P31850B	リンク(1)スプロケットシュー	Link (1) sprocket shoe
16	4P55055B	間座アオリバネ	Tilting spring washer
17	6NM11040F	ナットM4.0	Nut M4.0
18	6M60250601	トラス小ネジ M625-4	Screw truss M625-6
19	P412237	摩擦車(2)ループセッター	Friction wheel 2
20	6M60250401	トラス小ネジ M625-4	Screw truss M625-4
21	4P31849	リンク(1)ループセッター	Link (1) loop setter
22	4P55616	間座摩擦車	Washer friction wheel
23	4P55230	ネジ(1)ループフォーマ	Loop former screw 1
24	4P55598	段付ネジリンク(1)スプロケットシュー	Screw link 1

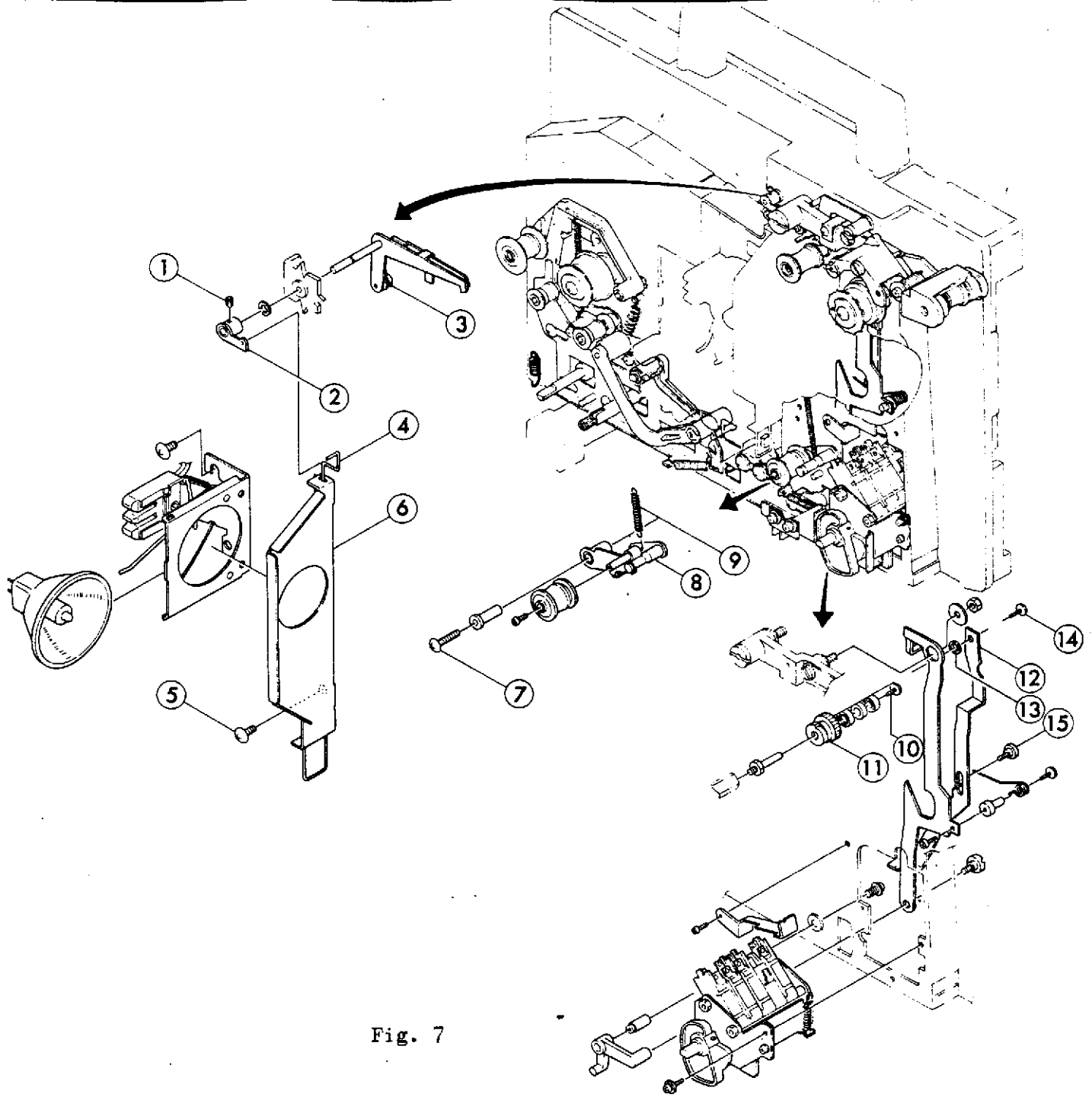

Fig. 7

Illustration No.	Parts No.	Parts Name
1	6M70300401	六角穴止メネジ M30-3 Screw M730-4
2	P412129	ホルダ組立リンク(2) Holder link (2) assy
3	P412352	レバー組立ループセッタ Lever loop setter assy
4	P412202	リンク(2)ループセッタ Link (2) loop setter
5	6M60300401	トラス小ネジ M630-5 Screw truss M630-4
6	4P31831B	シャッターカバー組立品 Shutter cover (2)
7	6M60402001	トラス小ネジ M640-20 Screw truss M640-20
8	P412179	レバー組立ガイドローラ(3) Lever guide roller 3
9	4P55597	バネガイドローラ(3) Spring guide roller 3
10	6M60250401	トラス小ネジ M625-4 Screw truss M625-4
11	P412237	摩擦車(2)ループセッタ Friction wheel 2
12	4P31849	リンク(1)ループセッタ Link (1) loop setter
13	4P55616	間座摩擦車 Washer friction wheel
14	6M60250601	トラス小ネジ M625-4 Screw truss M625-6
15	4P55230	ネジ(1)ループフォーマ Loop former screw 1

G. MACHINE FRAME - LOOP RESTORER

1. Disassembly

- (1) Remove Fig. 1-2, 19, 14, 10, 23, 18, 15.
- (2) Remove Fig. 7-6, 4 by detaching Fig. 7-5x2, after Fig. 7-2 is removed by loosening Fig. 7-1.
- (3) Remove Fig. 7-3.
- (4) Remove Fig. 7-8 in the following order:
 - * Remove Fig. 5-21.
 - * Remove Fig. 7-8 by detaching Fig. 7-7, 9.
- (5) Remove Fig. 7-12 in the following order:
 - * Remove Fig. 12-15.
 - * Remove Fig. 7-12 by detaching Fig. 7-14, 13, 15.
- (6) Remove Fig. 7-11 in the following order:
 - * Remove (b) in Fig. 4 and Fig. 4-10.
 - * Remove Fig. 7-14, 13, 15.
 - * Remove Fig. 7-11 by detaching Fig. 7-10.

2. Assembly

Follow the reverse way of the above steps.
After the assembly is completed, check the function of Loop Restorer.

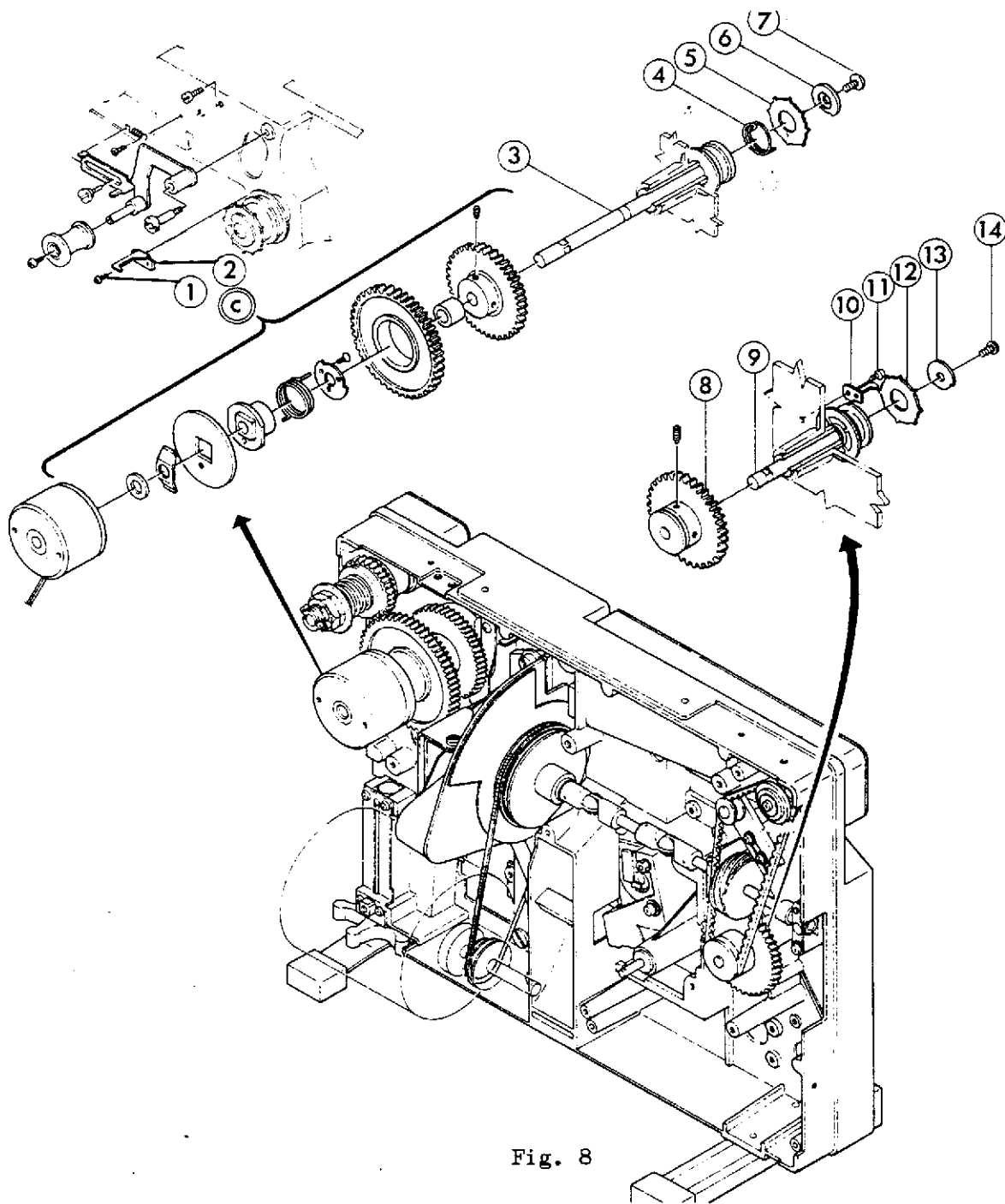

Fig. 8

Illustration No.	Parts No.	Parts Name	
1	6M70250401	ナベ小ネジ M725-4	Screw pan M725-4
2	P412181	巻込ヨケスプロケット	Film guide sprocket
3	P412159	第1スプロケット	First sprocket
4	4P55577	バネ第1スプロケット	Spring first sprocket
5	P412338	歯第1スプロケット	Cog first sprocket
6	P412141	キャップスプロケット	Cap sprocket
7	6M60400601	トラス小ネジ M640-6	Screw truss M640-6
8	P412161	ウォームギヤ(2)組立品	Worm gear (2) assy
9	P412183	第2スプロケット	Second sprocket
10	P412181	巻込ヨケスプロケット	Film guide sprocket
11	6M70250401	ナベ小ネジ M725-4	Screw pan M725-4
12	4P44463	16mmスプロケット	Sprocket
13	P412141	キャップスプロケット	Cap sprocket
14	6M60400601	トラス小ネジ M640-6	Screw truss M640-6

H. MACHINE FRAME - SPROCKET

1. Disassembly

- (1) Remove Fig. 1-18
- (2) Remove Fig. 8-5 by detaching Fig. 8-7,6.
- (3) Remove Fig. 8-3 in the following order:
(Use care not to make scratch on bearing.)
 - * Remove Fig. 8-2 by detaching Fig. 8-1.
 - * Remove Fig. 8-3 by detaching (c) in Fig. 8. (Refer to D-1)
- (4) Remove Fig. 8-12 by detaching Fig. 8-14,13.
- (5) Remove Fig. 8-9 in the following order:
(Use care not to make scratch on bearing.)
 - * Remove Fig. 8-10 by detaching Fig. 8-11.
 - * Remove Fig. 8-9 by detaching Fig. 8-8. (Refer to B-1)

2. Assembly

Follow the reverse way of the above steps, paying attention to the following point.

- (1) Use best care to prevent damage to cogs of gears which are attached to Fig. 8-3 when tightening Fig. 8-7 and also to cogs of Fig. 8-8 when tightening Fig. 8-14.

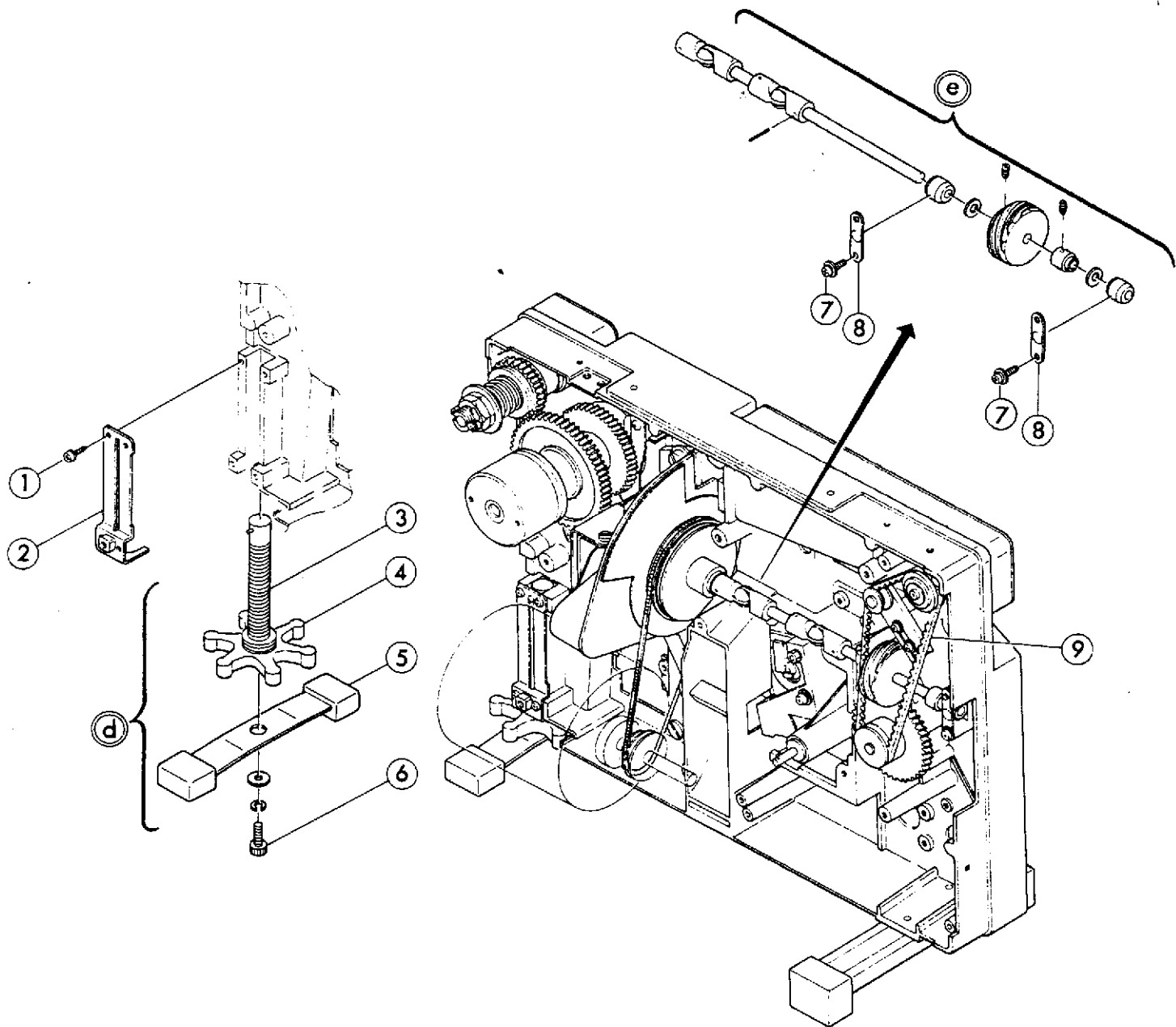

Fig. 9

Illustration No.	Parts No.	Parts Name	
1	6M7A300801	ナベ小ネジセムスA M730-6	Screw sems-A M730-8
2	P412243	取付金具アオリ棒	Metal tilting leg
3	P412178 B	アオリ棒	Tilting leg
4	P412146	アオリツマミ	Tilting knob
5	P412153 B	前足	Front leg
6	6FM3050125	六角穴付ボルト M5 - 12	Hexagon hole bolt M5 - 12
7	6M7B300801	ナベ小ネジセムスB M730-8	Screw sems-B M730-8
8	P412191 B	メタル押エ	Metal presser
9	P412203	Vベルト巻取	V belt take-up

I. MACHINE FRAME - TILTING

1. Disassembly

- (1) After Fig. 1-15 is removed, remove (1) in Fig. 14 as a unit.
- (2) Remove (d) in Fig. 9 by detaching Fig. 9-1x4,2.
- (3) Remove Fig. 9-3,4,5 by detaching Fig. 9-6.
Detach only Fig.9-6 when only Fig. 9-5 is to be removed.

2. Assembly

Follow the reverse way of the above steps.

J. MACHINE FRAME - UNIVERSAL JOINT

1. Disassembly

- (1) Remove Fig. 1-15.
- (2) Remove Fig. 9-9. (Refer to B-1)
- (3) Remove Fig. 9-8 by detaching Fig. 9-7.
- (4) Pull out (e) in Fig. 9 as a unit toward the rear side of projector.

2. Assembly

Follow the reverse way of the above steps.
After the assembly is completed, be sure to adjust the tension of Fig. 9-9. (Refer to B-2)

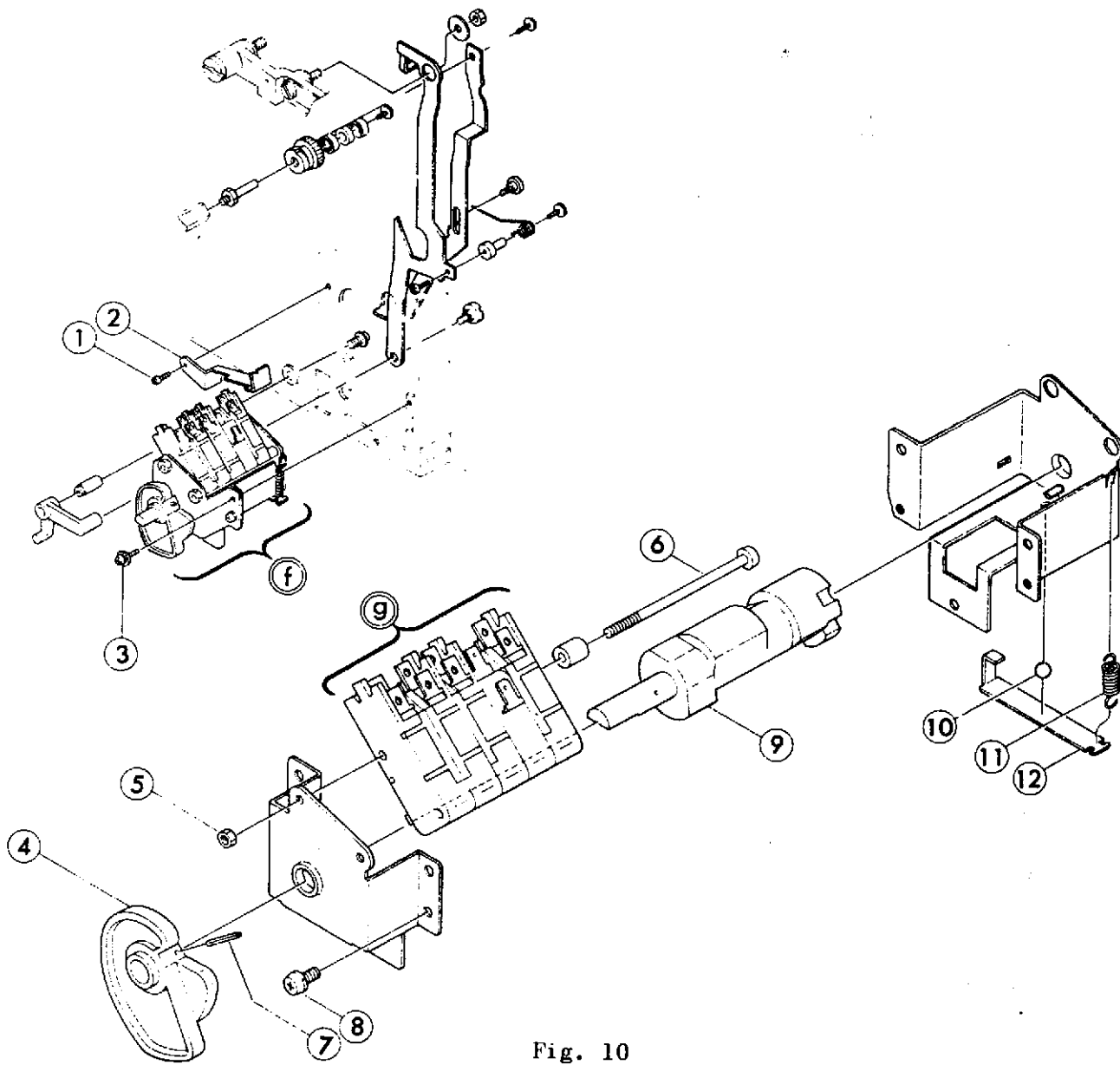

Fig. 10

Illustration No.	Parts No.	Parts Name	
1	6T74300601	ナベタッピングネジ 730-6	Tapping pan 730-6 (2L)
2	P412340	コード押エ	Cord supporter
3	6M7A300611	ナベ小ネジセムスB M730-8	Screw sems-B M730-6
4	P412173	カム連桿(1)	Cam link 1
5	6NM11030F	ナット M3.0	Nut M3.0
6	6M70306001	ナベ小ネジ M730-60	Screw pan M730-60
7	6J625140A	スパイロールピン	Spyrol pin
8	6M7A300601	ナベ小ネジセムスA M730-6	Screw sems-A M730-6
9	P412187	ストップピンスイッチカム	Cam switch
10	6G2040	スチールボール 4D	Steel ball 4mm
11	1P55593	クリックバネスイッチカム	Click spring switch cam
12	P412142	レバークリックバネ	Lever click spring

K. MAIN SWITCH

1. Disassembly

- (1) Remove Fig. 1-18,10,23.
- (2) Remove Fig. 5-21. (Refer to E-1)
- (3) Remove Fig. 10-2 by detaching Fig. 10-1.
- (4) Remove (f) in Fig. 10 by detaching Fig. 10-3x3 and disconnect lead wires of (g) in Fig. 10.
Use care not to touch Fig. 10-8.
- (5) Remove (g) in Fig. 10 by detaching Fig. 10-5x2,6x2.
- (6) Remove Fig. 10-7.
(Fig. 10-4 can be removed before Main Switch is disassembled)
- (7) Remove Fig. 10-10,12 by detaching Fig. 10-11.
- (8) Remove Fig. 10-9 by detaching Fig. 10-8x2.

2. Assembly

Follow the reverse way of the above steps.

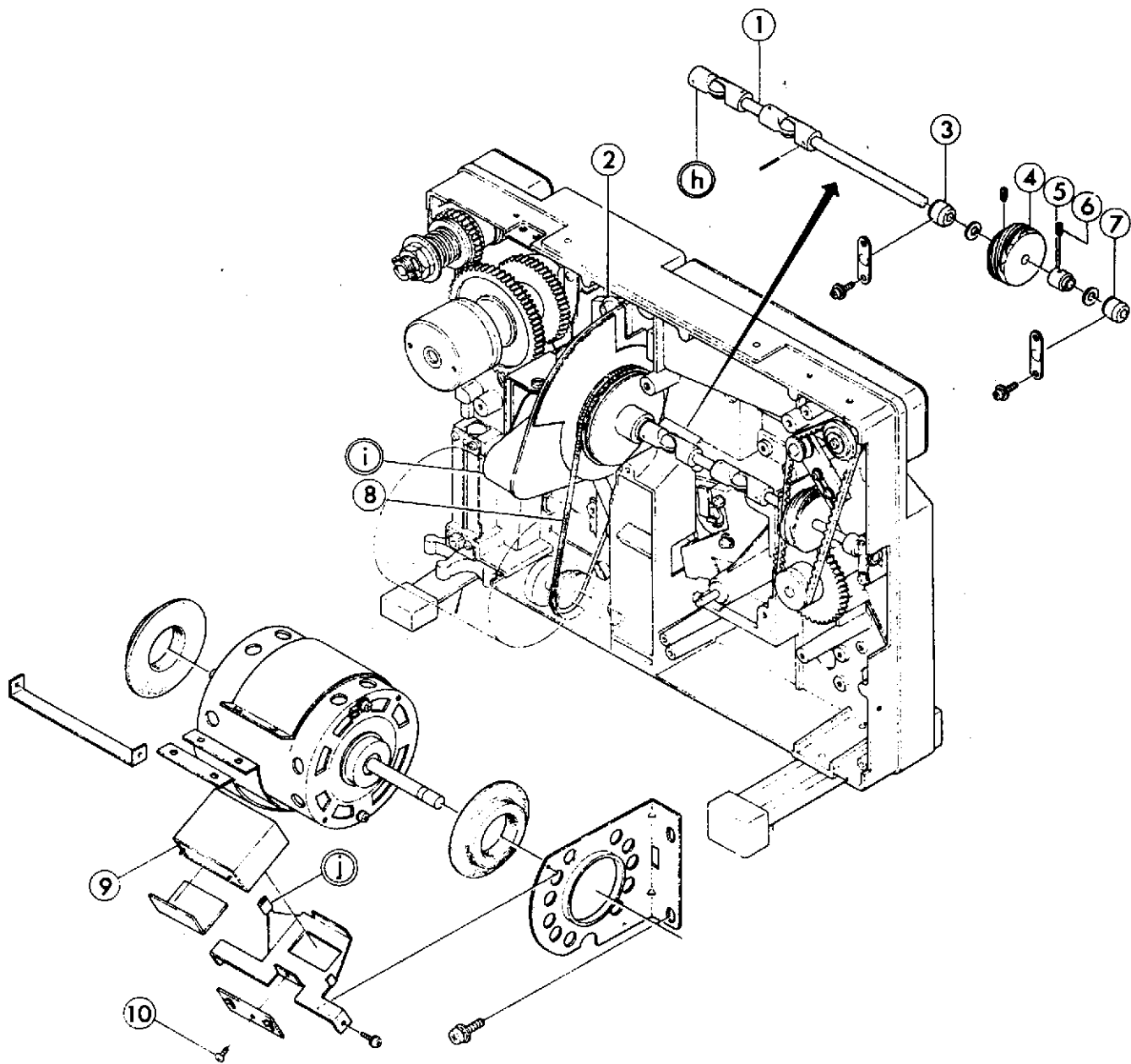

Fig. 11

Illustration No.	Parts No.	Parts Name	
1	P411686	中間軸(1)	Universal joint
2	4P55081	ネジフレーム給送部	Frame fix screw
3	1P46460	メタル中間軸	Middle shaft metal
4	P412285	ウォーム(2)	Worm 2
5	1P49039	開座主軸	Main shaft washer
6	6MT4300305	六角穴止メネジ M30-3	Set screw hexagon M30-3
7	1P46460	メタル中間軸	Middle shaft metal
8	6VV3M375	Vベルトメイン3M375	V belt main 3M375
9	5DJ0172211	コンデンサ10 μ F-220V	Polyest film 10 μ F-220wV
10	6M70300401	ナベ小ネジ M730-4	Screw pan M730-4

L. CLAW SECTION

1. Dismounting

- (1) Remove Fig. 1-15.
- (2) After (j) in Fig. 11 is raised up, remove Fig. 11-9 by detaching Fig. 11-10.
- (3) After Fig. 2-8 is removed, loosen Fig. 11-6x2 and disconnect the joint between Fig. 11-1 and (h), pushing Fig. 11-1 toward the rear side of projector by screwdriver.
(Refer to B-1)
- (4) Remove Fig. 11-8 from (i) in Fig. 11.
- (5) Set Fig. 1-22 at "Ⓢ" position and remove (i) in Fig. 11 by detaching Fig. 11-2x2.

2. Mounting

Follow the reverse way of the above steps, paying attention to the following point.

- (1) Be sure that there are no clearances between Fig. 11-3 and 4, and between Fig. 11-5 and 7.

Illustration No.	Parts No.	Parts Name	
1	4P41729D	マスキングカム	Masking cam
2	6M70300401	ナベ小ネジ M730-4	Screw pan M730-4
3	4P41731	アパーチュアプレート取付板	Aperture plate holder
4	P412199	押エ板アパーチュアプレート	A. P pressing plate
5	4P41884 C	マスキングカムガイド	Masking guide
6	4P32265	アパーチュアプレート	Aperture plate 2
7	P412347	組立フィルムガイド(1)	Film guide (1) assy
8	P412345	組立フィルム横押エ(1)	Film side presser 1
9	P412346	組立フィルム横押エ(2)	Film side presser 2
10	P412143	押エ板プレッシャプレート	Holder pressure plate
11	6M7B300801	ナベ小ネジセムスB M730-8	Screw sems-B M730-8
12	P412348	組立ホルダ(1)プレッシャプレート	Holder (1) presser plate
13	6MT4500805	六角穴止メネジ M50-8	Set screw hexagon M50-8
14	P412284	ウォーム(1)	Worm 1
15	P414075	間欠給送装置フレーム	Frame claw unit
16	P411318 B	三角カム	Triangle cam
17	P412993B	送り爪(1)組立品	Claw (1) assy
18	P411324	送り爪(2)	Claw 2
19	P411325	送り爪枠	Slide plate claw
20	6M70300501	ナベ小ネジ M730-5	Screw pan M730-5
21	4P31692	蓋給送部	Frame lid
22	6M80300601	平小ネジ M830-6	Screw FL-PLS M830-6
23	6MT4500805	六角穴止メネジ M50-8	Set screw hexagon M50-8
24	4P31852	組立シャッター(1)	Shutter (1) assy
25	P411335 C	三角カム軸組立品	Triangle cam shaft assy
26	P411317B	面カム	Face cam
27	6M70250801	ナベ小ネジ M725-8	Screw pan M725-8
28	P411323	ピン送り爪	Claw pin
29	P411326	バネ送り爪枠	Spring slide plate claw
30	P411327 B	バネ送り爪	Spring claw
31	P412350B	プレッシャプレート組立品	Pressure plate assy
32	4P55653	プレッシャプレートバネ	Spring pressure plate

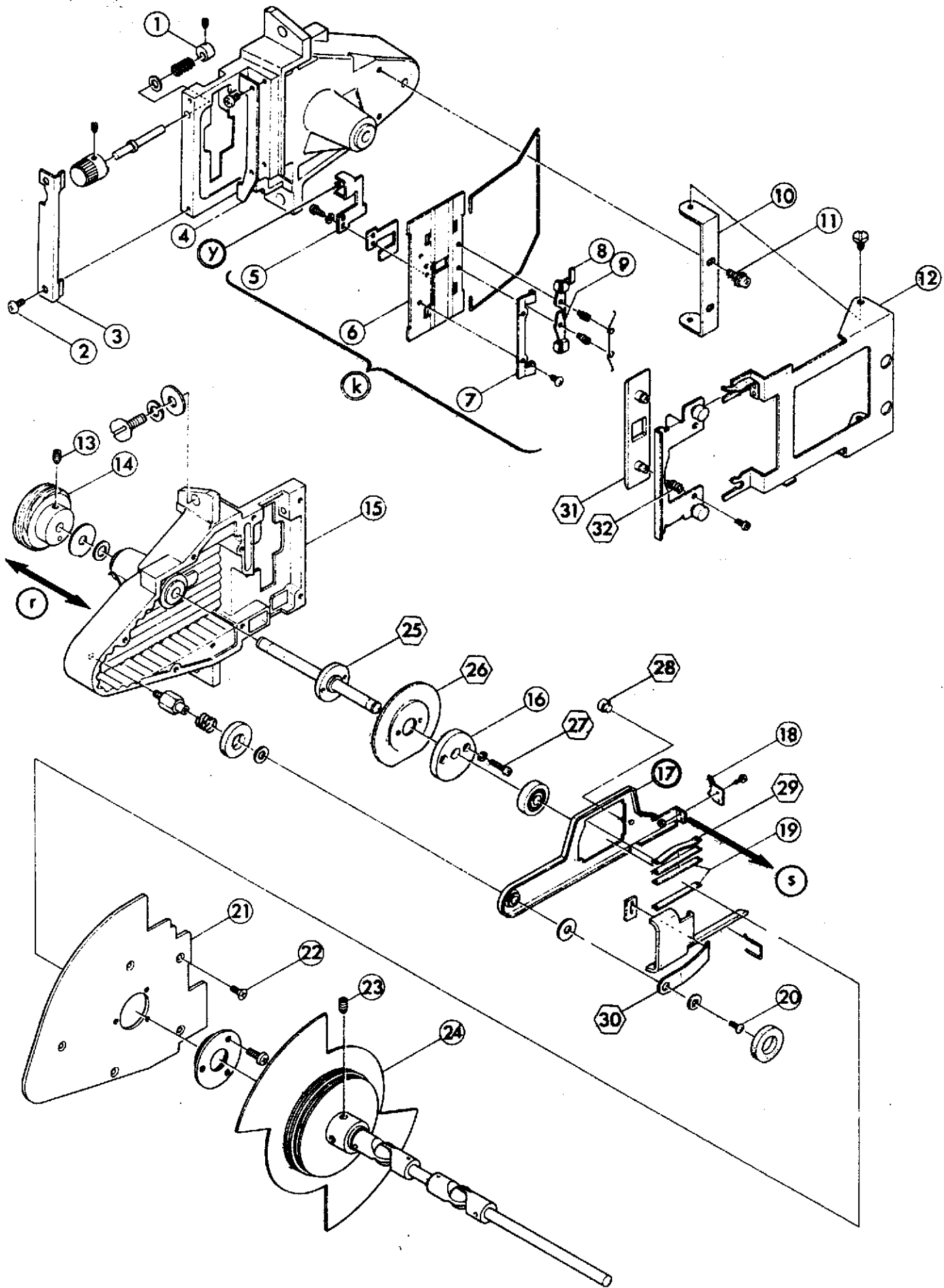

Fig. 12

3. Disassembly

- (1) Remove (k) in Fig. 12 by detaching Fig. 12-2x2,3.
- (2) Remove Fig. 12-10,12 by detaching Fig. 12-11x2.
- (3) Remove Fig. 12-24 by detaching Fig. 12-23x2.
- (4) Remove Fig. 12-21 by detaching Fig. 12-22x5.
- (5) Remove Fig. 12-17 by detaching Fig. 12-20.
- (6) Remove Fig. 12-14 by detaching Fig. 12-13x2.
Fig. 12-14 can be removed without disassembling Claw Section.

4. Assembly

Follow the reverse way of the above steps, paying attention to the following points. (Refer to W-1)

- (1) When attaching Fig. 12-7, make certain that center of aperture opening (Fig. 12-6) coincide with that of film frame.
- (2) Keep approx. 0.3mm clearance between Fig. 12-8 and 9 when film is loaded.
- (3) Fig. 12-1 should not only closely contact with (y) in Fig. 12 but also smoothly move.
- (4) When Fig. 12-4 is attached, Fig. 12-6 should not only closely contact with Fig. 12-15 but also smoothly move.
- (5) Fig. 12-16 should not only closely contact with Fig. 12-19 but also smoothly move.
- (6) When Fig. 12-17,16 are replaced, check the following points:
 - * Protrudent length of tip of Fig. 12-18 from film surface. (1mm)
 - * Position of claw tip in a film perforation.
 - * Position of claw during the framing.
 - * Stroke of claw.
- (7) When attaching Fig. 12-24, adjust the timing of Fig. 12-24 and 18 so that pictures may not flow.
- (8) Apply liquid Gasket (semi drying type) on contacting surfaces of Fig. 12-21,15 and fix them with Fig. 12-22x5.

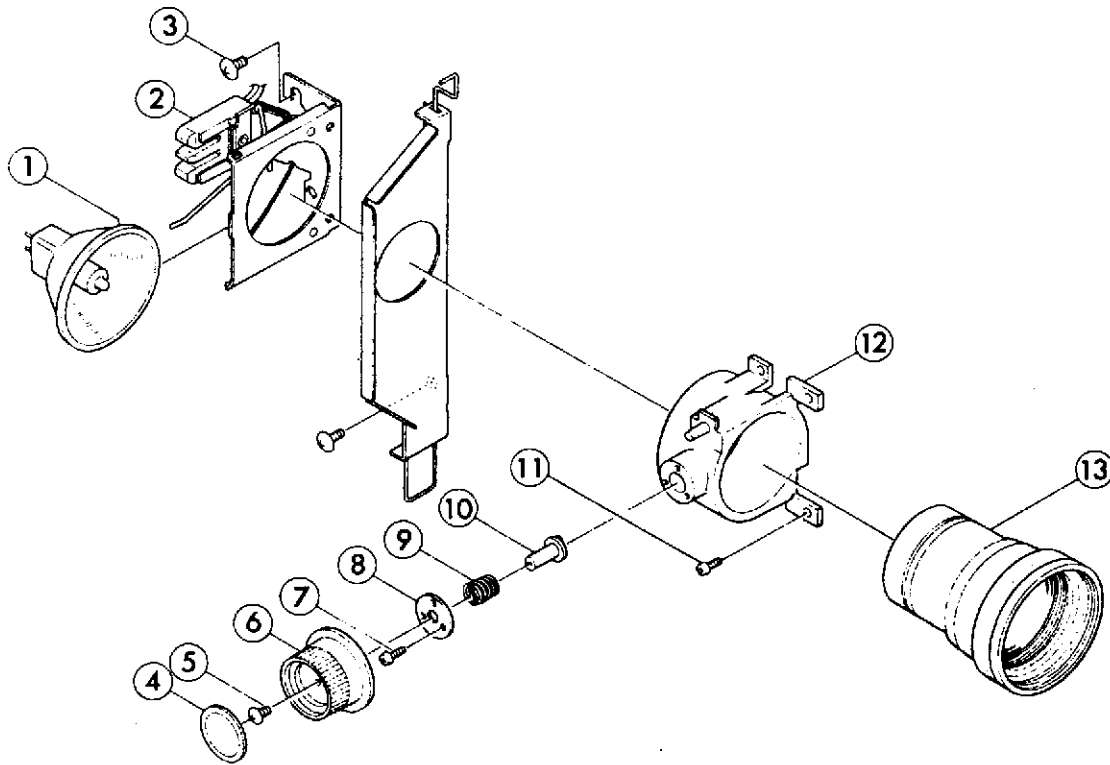

Fig. 13

Illustration No.	Parts No.	Parts Name	
1	5L42402514	映写ランプ JCR 24V-250W	Lamp 24V-250W ELC
2	5N1022	ランプソケット QEX-7	Lamp socket QEX-7
3	4P47107	ネジランプソケットホルダ	Lamp socket holder screw
4	4N02033	銘板(2)フォーカシングツマミ	Focusing plate 2
5	6M60250501	トラス小ネジ M625-6	Screw truss M625- 5
6	P412186	ツマミフォーカシング	Knob focusing
7	6M70250401	ナベ小ネジ M725-4	Screw pan M725-4
8	P415229	映写レンズフォーカシング座	Focusing mount
9	4P35631	バネフォーカシングツマミ	Spring focusing knob
10	P412175	軸フォーカシングツマミ	Shaft focusing knob
11	6M70250801	ナベ小ネジ M725-6	Screw pan M625-8
12	4P31824	ホルダ映写レンズ	Holder projection lens
13	4LB0514	映写レンズ F1.3-50mm	Lens (F1.2-50mm)

M. PROJECTION LENS

1. Disassembly

- (1) Remove Fig. 1-18,14.
- (2) Remove Fig. 13-13 by pulling out Fig. 13-6.
- (3) After Fig. 13-4 is detached from Fig. 13-6, remove Fig. 13-6 by detaching Fig. 13-5.
- (4) Remove Fig. 13-9,10 by detaching Fig. 13-7x3,8.
- (5) Remove Fig. 13-12 by detaching Fig. 13-11x4.

2. Assembly

Follow the reverse way of the above steps, paying attention to the following points:

- (1) First attach Fig. 13-12 slightly with Fig. 13-11x4. Then fix Fig. 13-12 by tightening Fig. 13-11x4 and pushing it downward.
- (2) When Fig. 13-4 is removed, be sure to replace it with new one.

N. PROJECTION LAMP

1. Disassembly

- (1) Remove Fig. 1-2.
- (2) Remove Fig. 13-2 by detaching Fig. 13-1,3x2.

2. Assembly

Follow the reverse way of the above steps, paying attention to the following point.

- (1) When Fig. 13-2 is re-attached, be sure to check and adjust the leveled screen brightness.

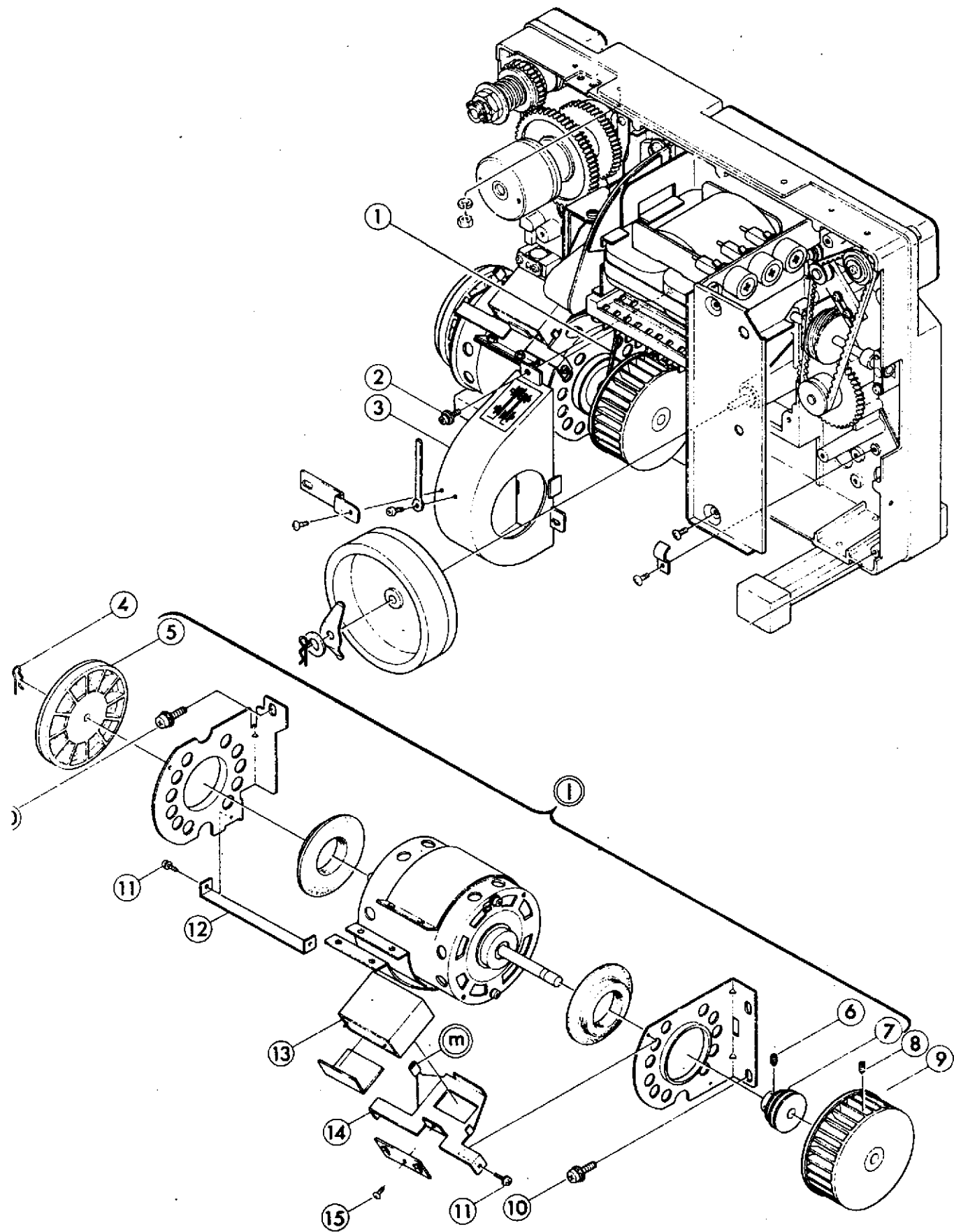

Fig. 14

0. MOTOR

1. Disassembly

- (1) Remove Fig. 1-10, 23, 18, 15.
- (2) After Fig. 10-2 is removed, disconnect lead wires of the motor.
- (3) Raising (m) in Fig. 14 up, remove Fig. 14-13 by loosening Fig. 14-15.
- (4) Remove Fig. 14-3 by detaching Fig. 14-2x2.
- (5) Remove Fig. 14-10x4.
- (6) Remove Fig. 14-9 by detaching Fig. 14-8.
- (7) Remove (l) in Fig. 14 as a unit, unfastening Fig. 14-1 from (l).
- (8) Remove Fig. 14-5 by detaching Fig. 14-4.
- (9) Remove Fig. 14-7 by detaching Fig. 14-6x2.
- (10) Remove Fig. 14-12, 14 by detaching Fig. 14-11x4.

2. Assembly

Follow the reverse way of the above steps, paying attention to the following point.

- (1) Adjust the position of (l) in Fig. 14 so that the adequate belt tension is obtained.
And be sure that (l) in Fig. 14 does not interfere with other parts.

Illustration No.	Parts No.	Parts Name	
1	6VV3M375	Vベルトメイン3M375	V belt main 3M375
2	6M7B300801	ナベ小ネジセムスB M730-8	Screw sems-B M730-8
3	4P31837	ファンケーシング	Fan casing
4	6Z0006	スナップピン	Snap pin
5	6Z0005	ファン	Motor fan
6	6MT4400605	六角穴止メネジ M40-6	Set screw hexagon M40-6
7	P412240	プーリ(1)モータ	Pulley (1) motor
8	6MT4400605	六角穴止メネジ M40-6	Set screw hexagon M40-6
9	P412292	ファン	Fan
10	6M7B501201	ナベ小ネジセムスB M750-12	Screw sems-B M750-12
11	6M7A300601	ナベ小ネジセムスA M730-6	Screw sems-A M730-6
12	P411613	ホルダー(3)モータ	Holder (3) motor
13	5DJ0172211	コンデンサ 10 μ F-220V	Polyest film 10 μ F-220wV
14	P412320	ホルダコンデンサ	Holder condenser
15	6M70300401	ナベ小ネジ M730-4	Screw pan M730-4

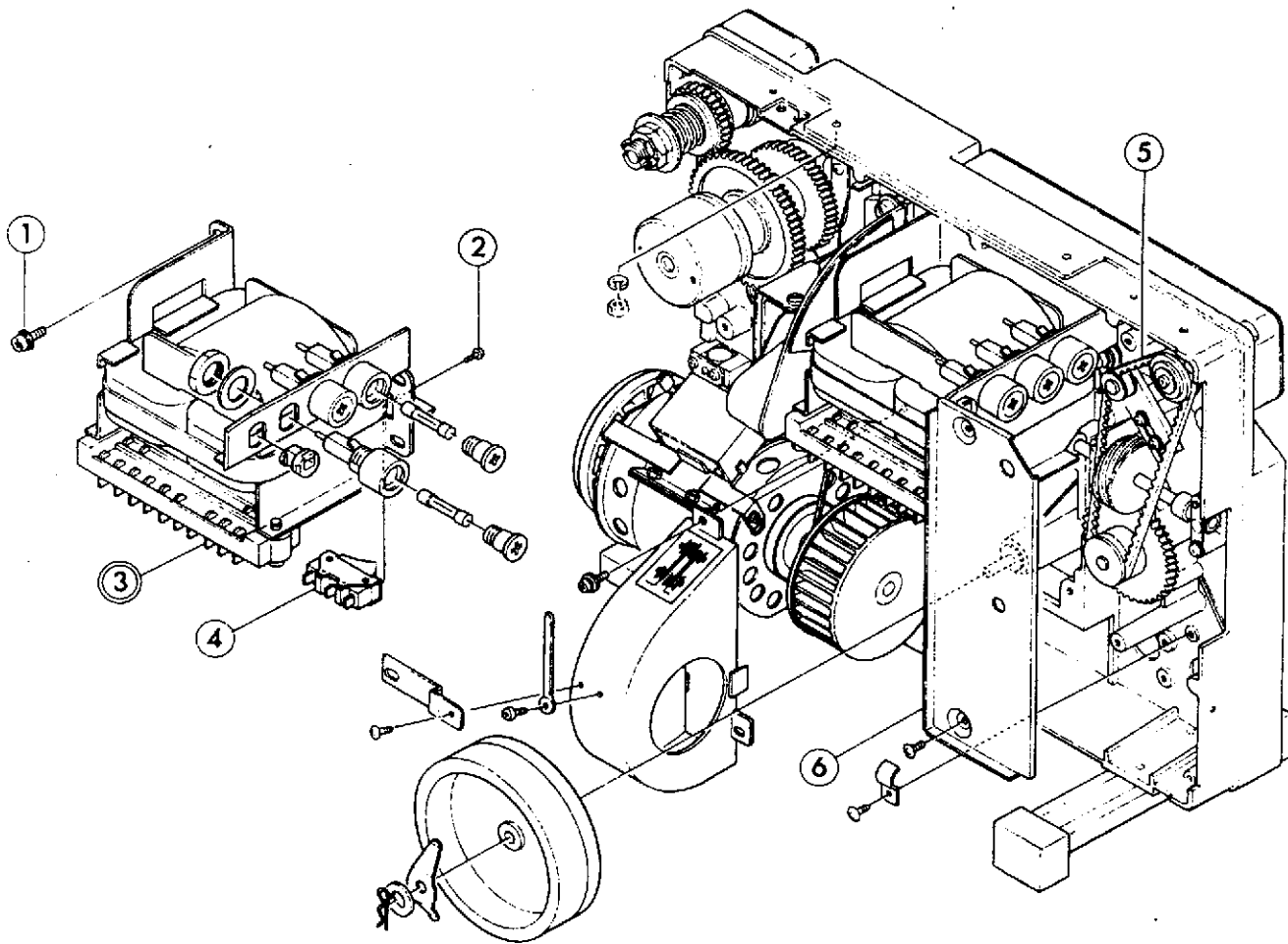

Fig. 15

Illustration No.	Parts No.	Parts Name	
1	6M7B501201	ナベ小ネジセムスB M750-12	Screw sems-B M750-12
2	6M70250401	ナベ小ネジ M725-4	Screw pan M725-4
3	4E20446	電源トランス(1)組立品	Transformer (1) assy
4	5E6009	波動スイッチ WD-31019	Seesaw switch WD-31019
5	P412203	Vベルト巻取	V belt take-up
6	P112190	アテ板裏カバー	Rear cover plate

P. TRANSFORMER

1. Disassembly

- (1) Remove Fig. 1-10, 23, 18, 15.
- (2) Remove Fig. 15-6, 5.
- (3) Disconnect lead wires of Fig. 15-3.
- (4) Remove Fig. 15-3 by detaching Fig. 15-1x4.
- (5) Remove Fig. 15-4 by detaching Fig. 15-2x2.

2. Assembly

Follow the reverse way of the above steps, paying attention to the following point.

- (1) Adjust the tension of Fig. 15-5.

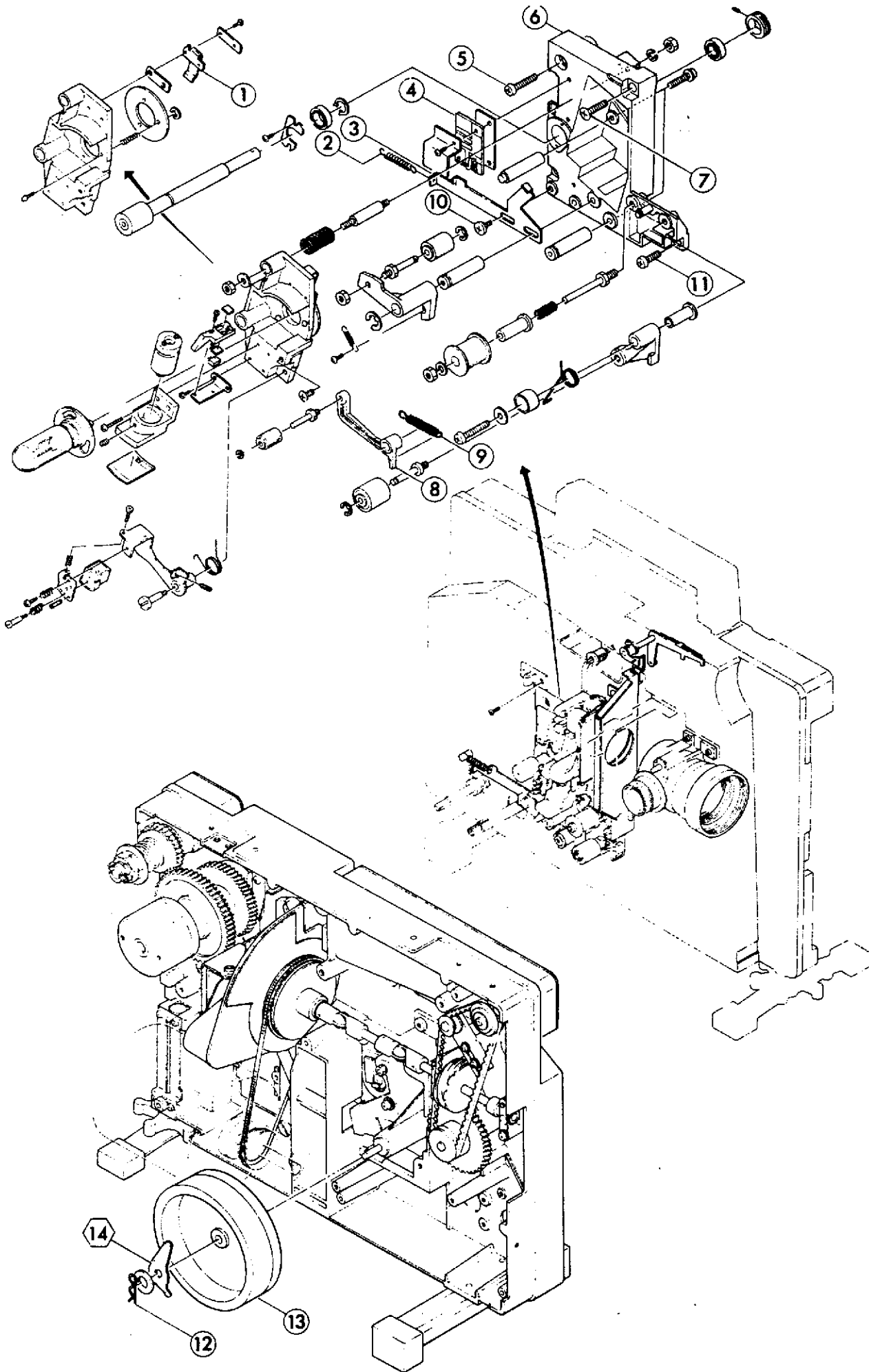

Fig. 16 - 31 -

Q. SOUND BASE PLATE

1. Dismounting

- (1) Remove Fig. 1-2, 14, 18, 10, 13, 15.
- (2) Remove Fig. 16-13 by detaching Fig. 16-12.
- (3) Unsolder the end of lead wire of Fig. 16-1.
- (4) Set lead wires of Fig. 16-4 free by detaching their cord pressers and connector, Fig. 18-5.
- (5) Remove Fig. 16-8 by detaching Fig. 5-21 and Fig. 16-9. (Refer to E-1)
- (6) Remove Fig. 16-3 by detaching Fig. 16-2, 10.
- (7) Remove Fig. 16-6 by detaching Fig. 16-5, 11, 7x2.

2. Mounting

Follow the reverse way of the above steps, paying attention to the following point.

- (1) When attaching Fig. 16-6, tighten Fig. 16-5, 11 after the position of Fig. 16-6 is fixed with Fig. 16-7x2.

Illustration No.	Parts No.	Parts Name	
1	P412092B	端子押エエキサイタランプ	Terminal exciter lamp
2	4P55978	バネパッドローラ	Spring lever (1) M-O cha.
3	P412104B	レバー(1)M-O切換	Lever (1) M-O switch
4	4E42720B	端子板ヘッド	Terminal head
5	6M70402001	ナベ小ネジ M740-18	Screw pan M740-20
6	4P20566C	ホルダフライホイール	Holder fly wheel
7	6M80402501	平小ネジ M840-20	Screw FL-PLS M840-25
8	P412057C	レバープレッシャローラ	Lever pressure roller
9	4P55551	バネプレッシャローラ	Spring pressure roller
10	4P55230	段付ネジ M-O 切換レバー(1)	Loop former screw 1
11	6M70401001	ナベ小ネジ M740-10	Screw pan M740-10
12	6Z0006	スナップピン	Snap pin
13	4P48612	フライホイール	Fly wheel
14	4P46467	バネフライホイール	Fly wheel spring

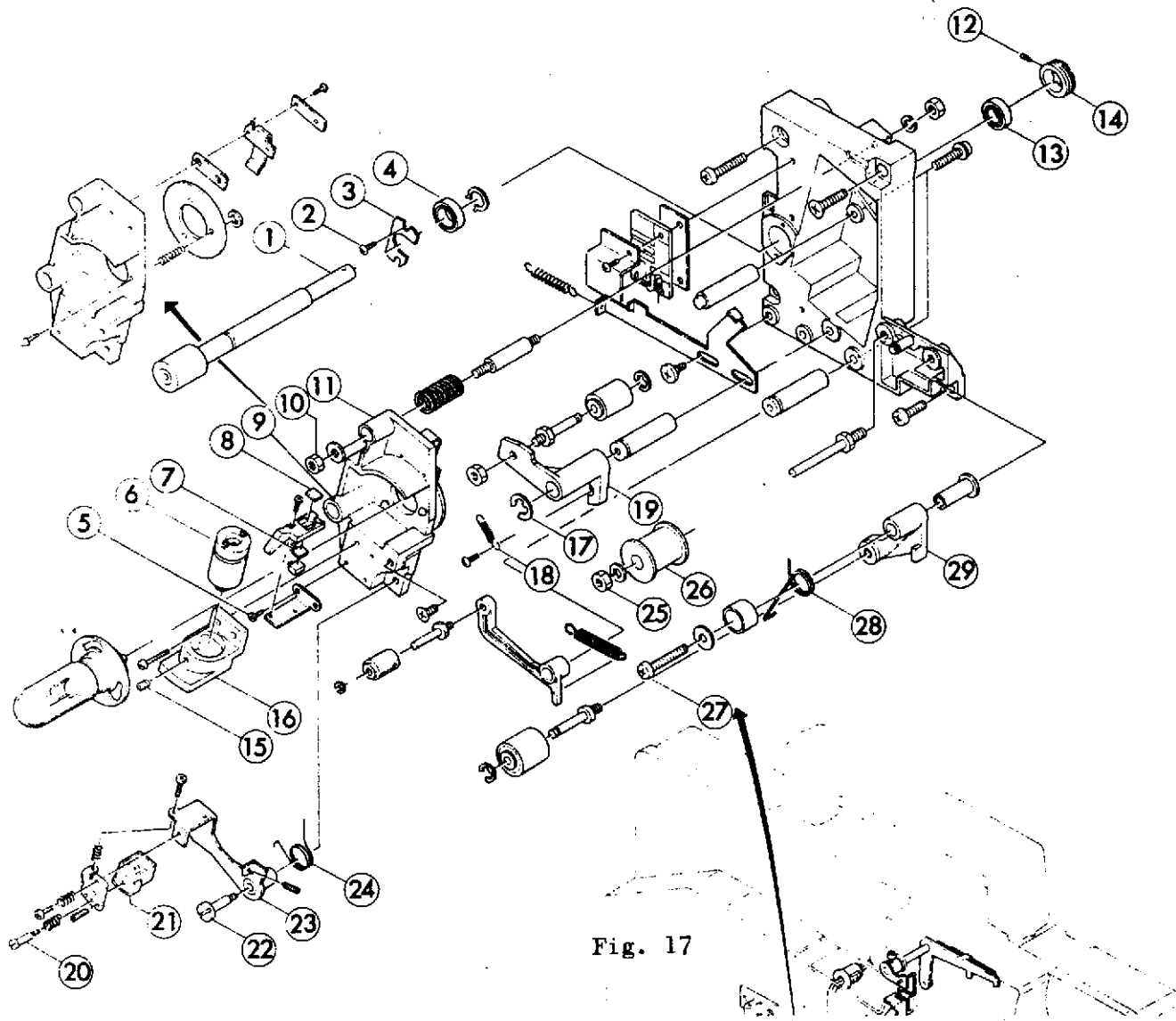

Fig. 17

Illustrator No.	Parts No.	Parts Name	
1	P412107	軸組立フライホイール	Shaft fly wheel assy
2	6M60200401	トラス小ネジ M620-4	Screw truss M620-4
3	P412103	押エ板ボールベアリング	Pressing plate bearing
4	6B20801201	ボールベアリング L-1280ZZ	Ball bearing SSL-1280ZZH
5	6M71200405	ナベ小ネジ M7120-4	Screw pan M7120-4
6	4P31862	サウンドレンズ組立品	Sound lens assy
7	5S4PD520UA	シリコンフォトダイオード	Photo diode PD-520UA
8	P412099	カバーフォトダイオード	Cover photo diode
9	6M70200401		Screw pan M720-4
10	6NM19040F	特殊ナット M4.0	Special nut M4.0
11	P412050B	ホルダエキサイタランプ	Holder exciter lamp
12	6MT0200305	止メネジ M20-3	Set screw M20-3
13	6B20601201	ボールベアリング SSL-1260ZZ	Ball bearing SSL-1260ZZ
14	P412722	ナットホルダフライホイール	Ring nut sound drum.
15	6MT4300305	六角穴止メネジ M30-3	Set screw hexagon M30-3

3. Disassembly

- (1) Remove Fig. 17-1,4 by detaching Fig. 17-2,3.
- (2) Remove Fig. 17-13 by loosening Fig. 17-12 and detaching Fig. 17-14.
- (3) Remove Fig. 17-26 by detaching Fig. 17-25.
- (4) Remove Fig. 17-29 by detaching Fig. 17-27,28.
- (5) Remove Fig. 17-19 by detaching Fig. 17-18,17.
- (6) After ends of lead wires of Fig. 17-21 are unsoldered, remove Fig. 17-23 by detaching Fig. 17-24,22.
- (7) Remove Fig. 17-21 by detaching Fig. 17-20x2.
- (8) Remove Fig. 17-11 by detaching Fig. 17-9,10.
- (9) After Fig. 17-5x2 are detached, remove Fig. 17-7 by detaching Fig. 17-8.
- (10) Remove Fig. 17-6 by loosening Fig. 17-15.

Note: Above (1) - (4) four steps can be done without dismounting of Sound Base Plate.

Do not remove Fig. 17-16 as it is impossible to restore it to the original position without using special tool.

4. Assembly

Follow the reverse way of the above steps, paying attention to the following point.

- (1) Adjust the position of Fig. 17-6,7,11,21,26. (Refer to X-1)

16	P412233	ホルダサウンドレンズ	Holder sound lens
17	6QEA0060	Eリング ER-6	E-ring ER-6
18	4P55549	バネパッドローラ	Spring pad roller
19	P412056 C	レバーパッドローラ	Lever pad roller
20	P412095 B	ネジヘッド	Screw head
21	4E42473	録音再生ヘッド WY-020	Sound head MH-16
22	4P54451	セレクタレバー軸	Selector lever shaft
23	P412093 B	レバー組立ヘッド	Lever head assy
24	4P55540	バネヘッドレバー	Spring head lever
25	6NML9030F	特殊ナット M4.0	Special nut M3.0
26	P414947	制動ローラ(1)	Brake roller 3 assy
27	6M60402501	ナベ小ネジ M740-20	Screw truss M640-25
28	4P55547	バネ制動ローラ(2)レバー	Spring brake roller 2
29	P412049C	レバー制動ローラ(2)	Lever brake roller 2

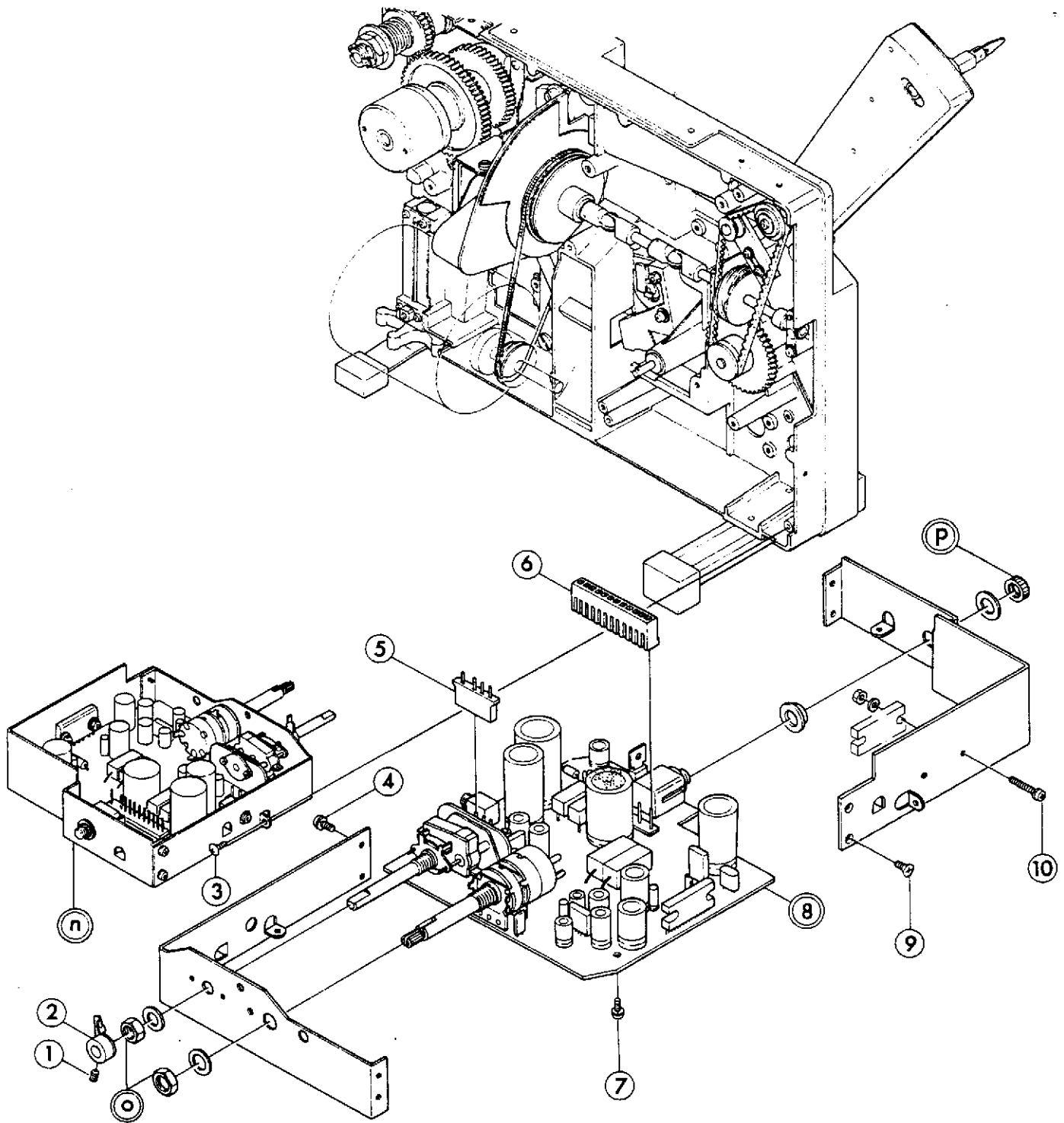

Fig. 18

Illustration No.	Parts No.	Parts Name	
1	6M70300401	六角穴止メネジ M30-4	Screw pan M730-4
2	P412207	組立レバー(2) M-O切換	Lever (2) M-O switch assy
3	6M7A300601	トラス小ネジ M630-6	Screw sems-A M730-6
4	6M80300601	ナベ小ネジセムスA M730-6	Screw M830-6
5	5N204122	4Pコネクタ S-I 2502	4P connector S-I 2502 2
6	4P8CL0041	11Pコネクタ 5065-11	11P connector cord
7	6777300608	ナベ小ネジセムスA M730-6	Screw T730-6
8	4P8CL0008	アンプ組立品	Amplifier assy
9	6777300608	平小ネジ M830-6	Screw T730-6
10	6777301208	ナベ小ネジセムスA M730-12	Screw T730-12

R. AMPLIFIER

1. Disassembly

- (1) Remove Fig. 1-3, 8, 9, 15.
- (2) Remove Fig. 18-5, 6.
- (3) Remove (n) in Fig. 18 by detaching Fig. 18-3x3.
- (4) After Fig. 18-1, 2 are detached, remove (o) in Fig. 18 by turning it counterclockwise.
- (5) Remove Fig. 18-10x2.
- (6) Remove (p) in Fig. 18 by turning it counterclockwise.
- (7) Remove Fig. 18-7x3.
- (8) Remove Fig. 18-8 by detaching Fig. 18-4x2, 9x2.

2. Assembly

Follow the reverse way of the above steps.

II. ADJUSTMENT

S. TAKE-UP REEL ARM

Take-up Reel Arm of 16-CL has following two functions, which can be adjusted at a time with the below-mentioned adjustment.

- * Function to take up film.
- * Function to give a sufficient back-tension to rewind film safely and smoothly.

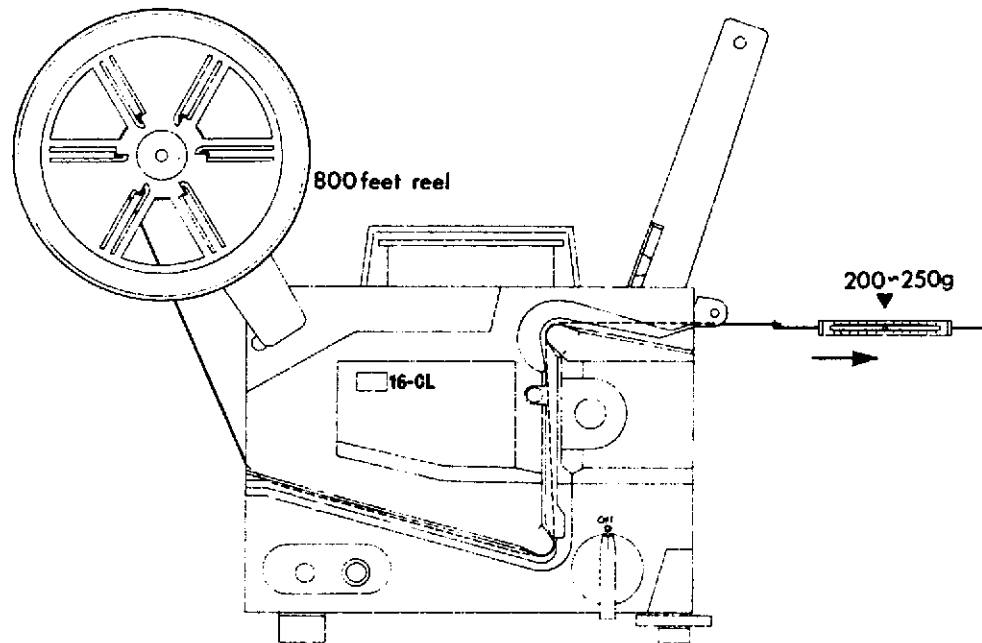

Fig. 19

1. Measurement:

- (1) As illustrated in Fig. 19, set Main Knob (Fig.1-22) at "OFF" position. And wind film on attached 800 ft Reel through Channel, and turn the reel for about 10 times by hand.
- (2) While pulling out the film in the direction of the arrow illustrated in Fig. 19, measure the tension by a tension gauge. The tension is to be 200-250gr.

2. Adjustment:

- (1) When Fig. 2-4 is damaged or stained with oil, etc., replace it.
- (2) Adjust the take-up tension of Fig. 2-4 by changing the tension of Fig. 2-6.
- (3) If Fig.2-16 is stained with oil, etc., remove stains.

T. REWINDING MECHANISM

Rewinding mechanism of 16-CL makes it possible to rewind the film through Channel quickly without any film damage as well as Reel-to-reel rewinding.

This rewinding mechanism consists of Feed Reel Arm, Delay Device (Delay Circuit, Magnet Clutch, etc.) and Slipping Mechanism.

16-CL is designed to rewind film with 70-80% lower torque than the normal torque only for 3-4 sec. after motor starts rewinding in order to prevent film damage. (Hereinafter this 3-4 sec. period is called "Delay Time".)

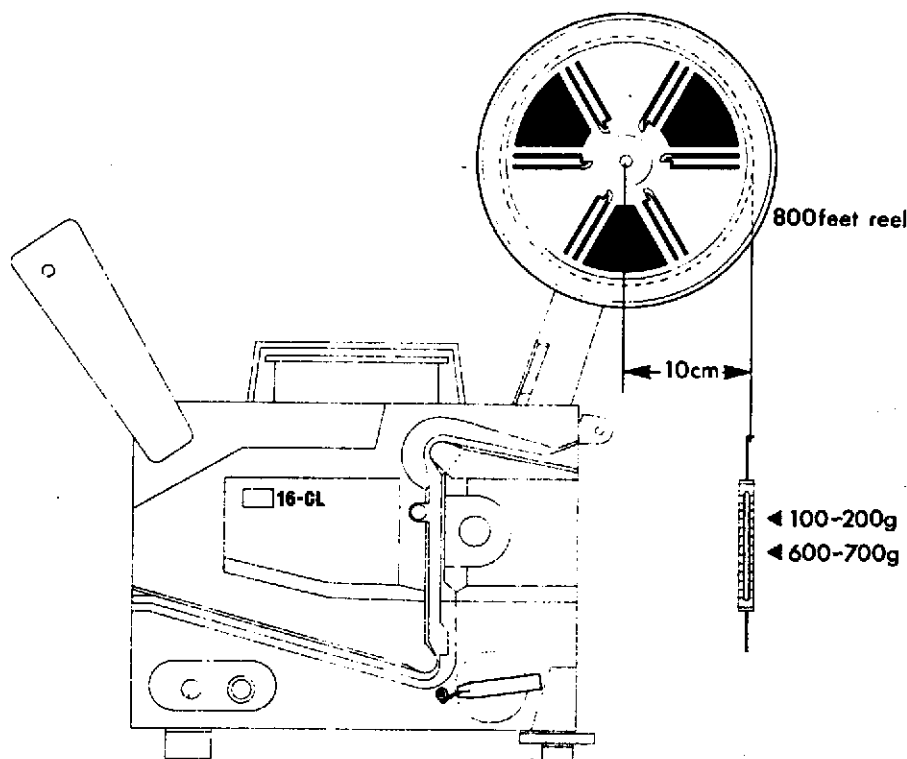

Fig. 20

1. Measurement:

- (1) As shown in Fig. 20, wind film on attached Reel until the diameter of wound film comes to 20cm.
- (2) Set Main Knob at "⊙" position and measure the tension as illustrated in Fig. 20.

The rewinding tension is to be the following:

- * 100-200gr. during the delay time of 3-4 sec.
- * 600-700gr. after this period.

2. Adjustment:

- (1) Adjust the tension of Fig. 3-4 by changing the position of Fig. 3-5 so that it may not slip.
- (2) Adjustment of clutch friction during the delay time of 3-4 sec:
 - * Fix the position of Fig. 22-2 by tightening Fig. 22-4 to keep 0.3mm clearance between Fig. 22-1 and 2.
 - * Rewinding tension is limited by the clutch friction, which is electrically controlled by R22 (Specified value: 560 ohms, Fig. 23). Large value of R22 results in less friction.
- (3) Adjustment of Delay Time:
 - * Delay time of 3-4 sec. is originally decided by the delay circuit and no adjustment is requested.
 - * When replacing the parts, be sure to use specified spare parts.
- (4) Adjustment of clutch friction after the delay time:
 - * Loosen Fig. 21-1 by turning it counterclockwise.
 - * Change the pressure of Fig. 21-3 by turning Fig. 21-2 in order to adjust the tension to 600-700gr. (Refer to Fig. 20)
 - * After adjustment is completed, be sure to lock Fig. 21-1,2 by turning Fig. 21-1 clockwise.

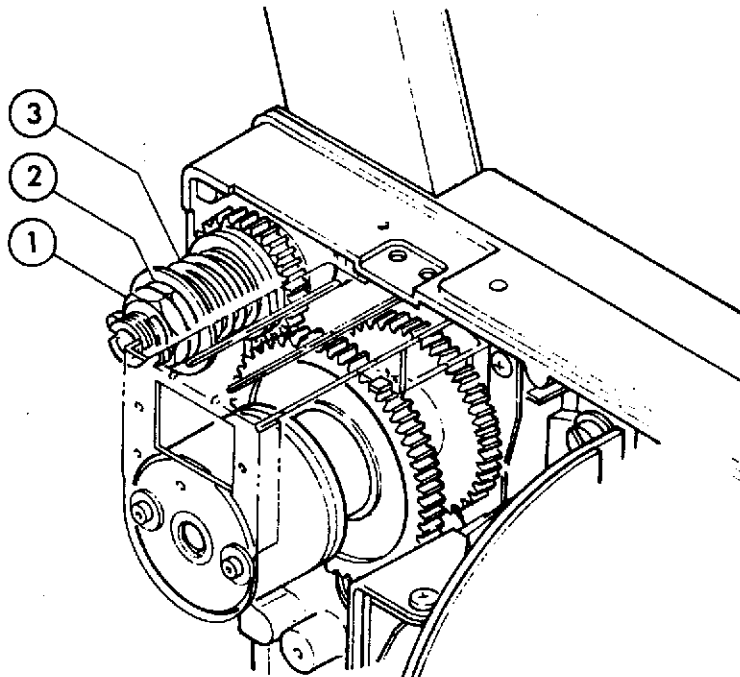

Fig. 21

Illustration No.	Parts No.	Parts Name	
1	4P55599	ナット摩擦板	Nut friction plate
2	4P55599	ナット摩擦板	Nut friction plate
3	4P55600	バネ摩擦板	Spring friction plate

3. Magnet Clutch:

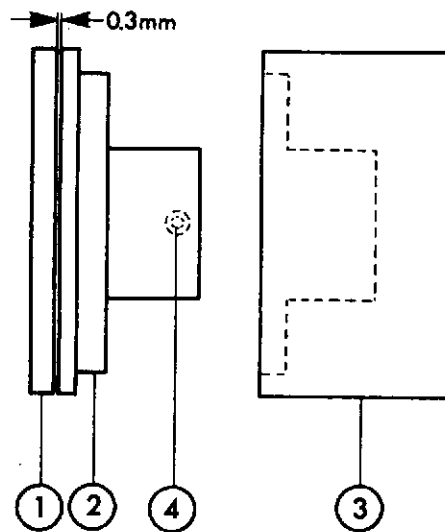

Fig. 22

Illustration No.	Parts No.	Parts Name	
1		クラッチ板	Clutch plate
2		ローター	Rotor
3		マグネット	Magnet
4	6MT4400305	六角穴止メネジ M40-3	Set screw hexagon M40-3

Magnet Clutch works in accordance with applied voltage to the clutch as follows:

- (1) Approx. 12V (for the delay time of 3-4 sec.):

Due to Delay Circuit, attractive force of Fig. 22-3 is weaker than regular force. And, for smooth and safe rewinding, slip occurs between Fig. 22-1 and 2 so that the rewinding tension may come to 100-200gr.

- (2) 37V (after the delay time):

As attractive force comes to the regular level, Fig. 22-1 rotates together with Fig. 22-2 without slip. In this instance, the tension depends on the pressure of Fig. 21-3.

4. Delay Circuit:

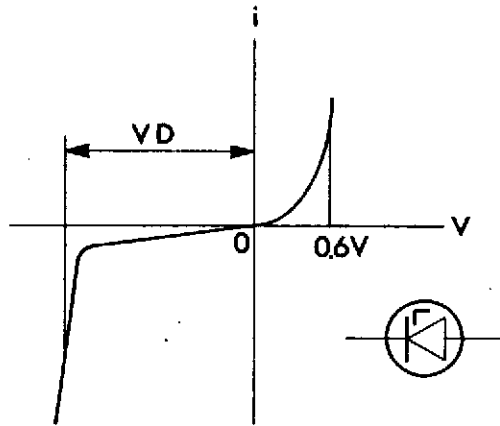
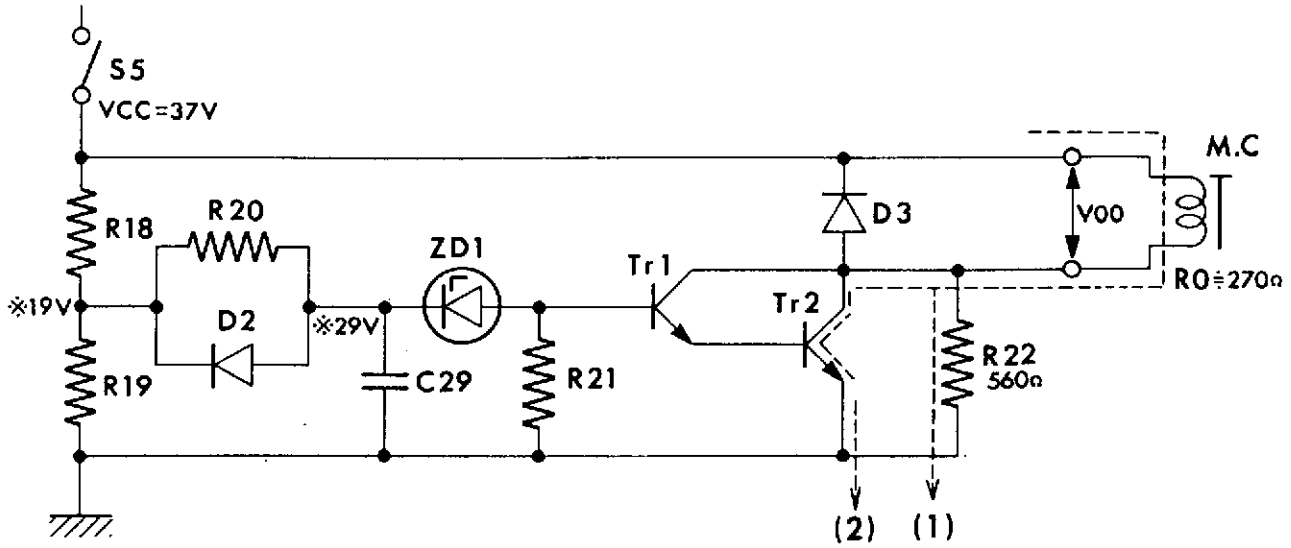

Fig. 23

The nature of Zener Diode is put to use in Delay Circuit.

- Zener Diode:
- * Current flows in forward direction.
 - * Current does not flow in reverse direction when applied voltage is lower than a certain level which is called "Zener Voltage (VD)".
 - * Current starts to flow in reverse direction when applied voltage exceeds the Zener Voltage (VD).

Immediately after S-5 is switched on, most of current flow through R22 (Route (1)).

At this time, voltage applied to Magnet Clutch (Voo) is about 12V.

(Voo is calculated as $V_{oo} = V_{cc} \times \frac{R_o}{R_o + R22}$).

After S-5 is switched on, C29 is charged with the current through R20 and when the terminal voltage of C29 exceeds the Zener Voltage of ZD1, current starts to flow through ZD1, Tr1 and Tr2.

The current, which flows through R22 during the delay time, turns to flow through Tr2.

In the end, all current flow through Tr2 as the Equivalent Resistance of Tr2 comes to nearly zero.

At this time, Voo is calculated as $V_{oo} = 37 \times \frac{270}{0 + 270} = 37V$,

i.e., Vcc of 37V is supplied to Magnet Clutch.

16-CL is so designed that it takes about 3-4 seconds to increase Voo from 12V to 37V (Delay Time).

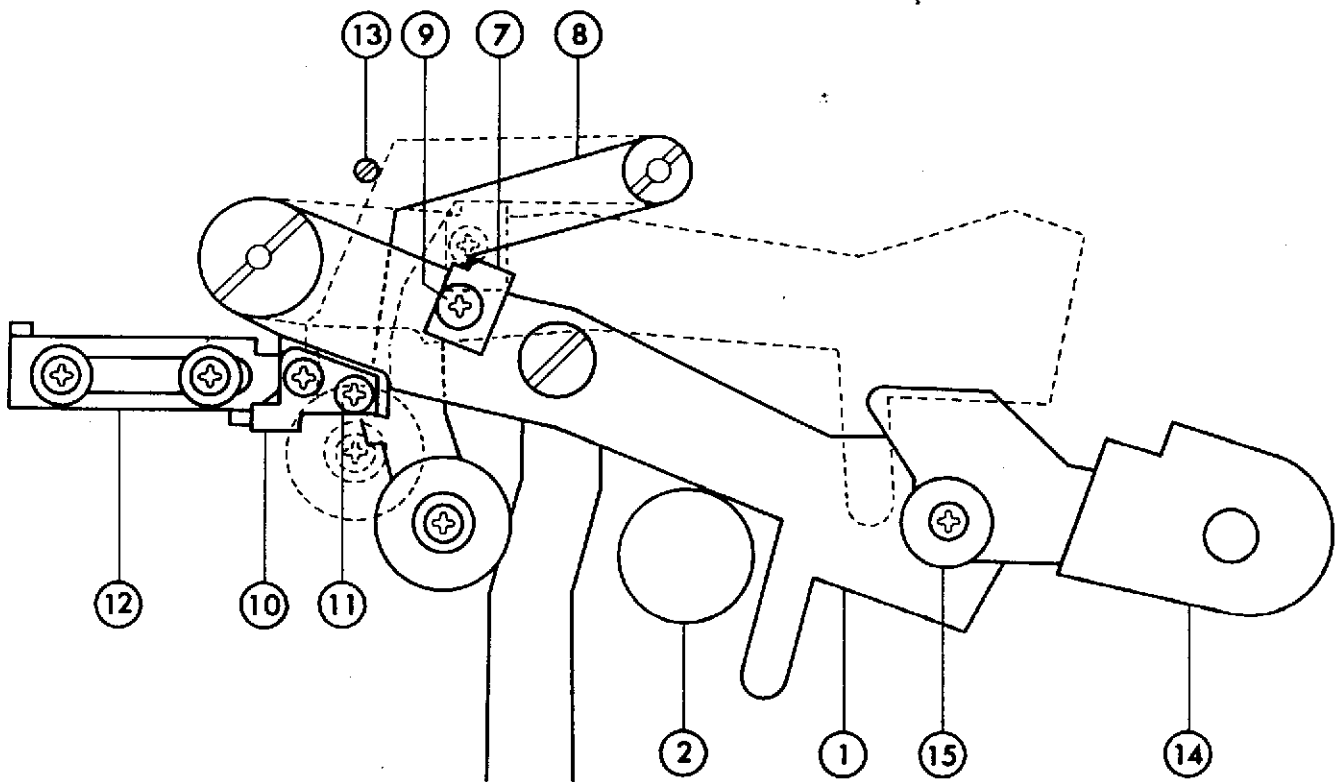

Illustration No.	Parts No.	Parts Name	
1	4P31827B	レバースプロケットシュー	Lever sprocket shoe
2		メタルスプロケット	Metal sprocket
3	4P31836C	連桿(1)	Link 1
4	P412173	カム連桿(1)	Cam link 1
5	P412166B	ホルダリンク(3)	Holder link 3
6	6M7B400801	ナベ小ネジセムスB M740-8	Screw sams-B M740-8
7	P412344	押エ板レバーガイドローラ(2)	Plate guide roller 2
8	P412157	レバー組立ガイドローラ(2)	Lever guide roller 2
9	6M60300601	トラス小ネジ M630-6	Screw truss M630-6
10	P412216B	ストッパガイドローラ(2)	Stopper guide roller 2
11	6M60250401	トラス小ネジ M625-4	Screw truss M625-4
12	P412204C	ストッパレバーガイドローラ(2)	Stopper lever roller 2
13	4P55791	ピンアームロック	Screw cover machine
14	4P31886	カバーガイドローラ(1)	Cover guide roller 1
15	4P55571	間座取付板ガイドローラ(1)	Washer holder roller 1
16	P412123	ホルダ(1)スイッチカム	Holder (1) switch cam

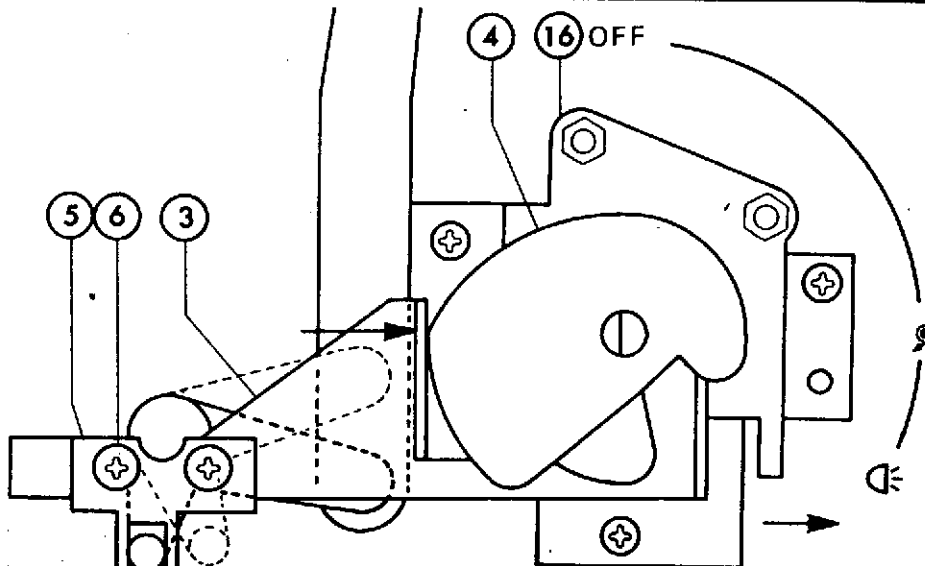

Fig. 24

U. LEVER

When Main Knob is set at "☉" or "☾" position, levers in 16-CL are pressed to each specified direction only by springs and do not interfere each other. So movable rollers at "☉" or "☾" keep correct position even after long use. Therefore, no adjustment of levers interlocked with Link (1) is requested except for Fig. 24-3,5,7,10.

1. Adjustment:

Check and adjust levers in the following order.

- (1) Location of Lever Sprocket Shoe (Fig. 24-1) when Main Knob is set at "☉" position:

- * Set Main Knob at "☉" position.
- * Fix Fig. 24-5 with Fig. 24-6x2, pushing Fig. 24-3 towards Fig. 24-4 and Fig. 24-5 towards the opposite direction of Fig. 24-4.
- * And after Main Knob is turned several times, make certain that there is no excessive clearance than 0.4mm between Fig. 24-1 and 2 at "☉" position.

- (2) Location of Lever Sprocket Shoe (Fig. 24-1) when Main Knob is set at "OFF" or "☾" position:

- * After the adjustment (1) is completed, set Main Knob at "OFF" position.
- * Fix Fig. 24-7 by tightening Fig. 24-9 at the position that Fig. 24-8 may slightly touch Fig. 24-13.
- * Location of Lever Sprocket Shoe at "☾" position can be automatically adjusted with the above steps.

- (3) Location of Stopper Guide Roller 2 (Fig. 24-10):

- * Fig. 24-8 forms the upper film loop, and Fig. 24-10 sets Fig. 24-8 free from Fig. 24-12.
- * Adjust the position of Fig. 24-10 by moving it to right or left so that, when turning Main Knob clockwise from "OFF", Main Knob may be held in "☉" position just after film perforation fits onto the tooth of First Sprocket (Fig. 8-5).

- (4) When attaching Fig. 24-14, adjust the position of Fig. 24-14 so that it may not touch 2000 ft Reel when Main Knob is set at "OFF" position.

- (5) Turn Fig. 24-15 counterclockwise so that the tension on Fig. 24-14 may come to 50-80gr. (Refer to F-2)

Note: If tension on Fig. 24-14 is not enough, film gets out of First Sprocket and it causes the length of upper film loop to be shortened.

- (6) When Fig. 24-16 is removed or replaced, fix Fig. 24-16, pushing it in the direction of the arrow illustrated in Fig. 24.

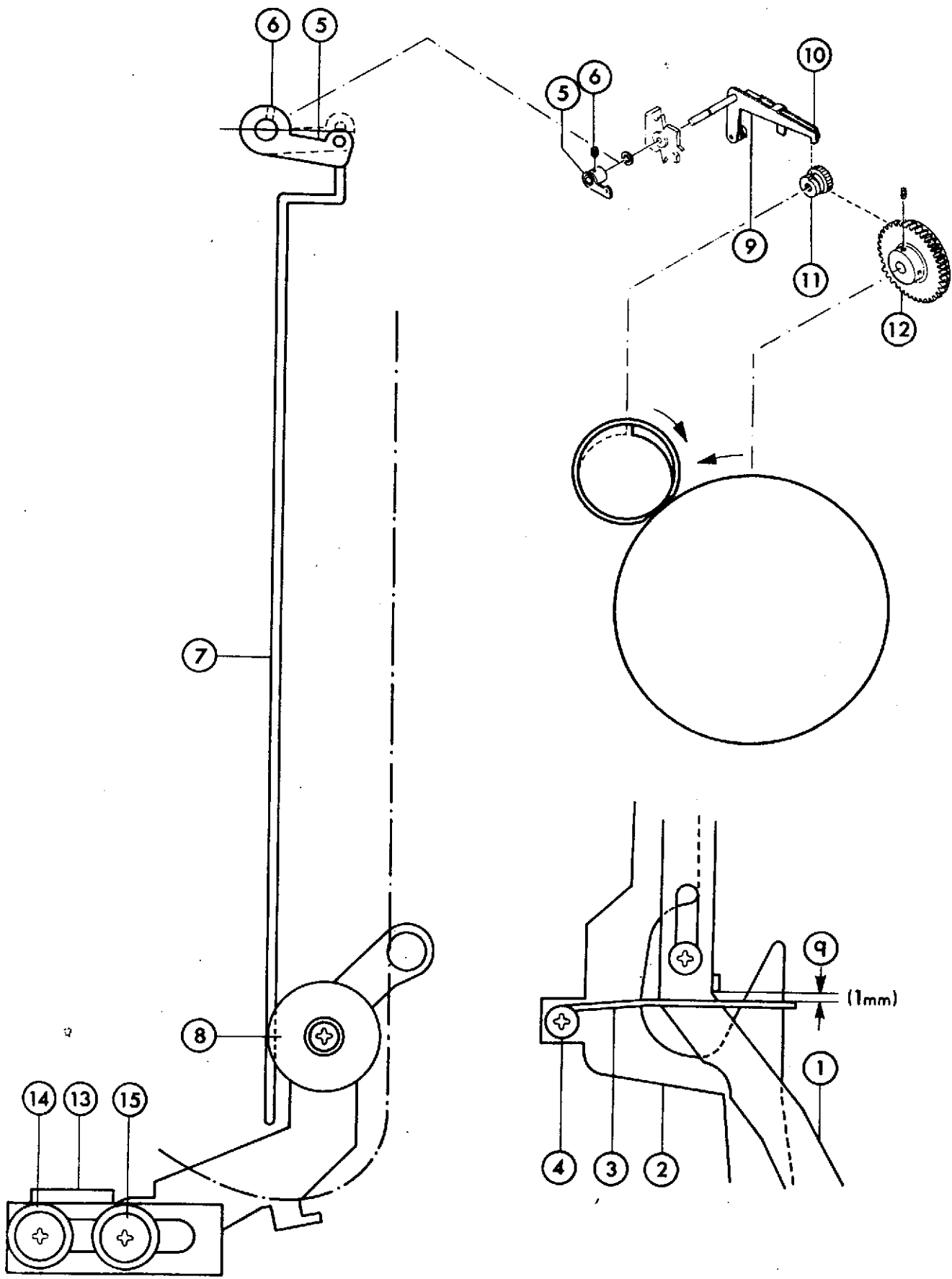

Fig. 25

V. LOOP RESTORER

Loop Restorer works as under:

- * The length of lower Film Loop is shortened.
- * Fig. 25-7 is pushed up by film.
- * Free-end of Fig. 25-5 is pushed up by Fig. 25-7.
- * Claw of Fig. 25-9 moves upwards.
- * Fig. 25-11 is set free from the claw of Fig. 25-9 and at the same time Fig. 25-10 pushes Fig. 25-11. Then Fig. 25-11 rotates slightly.
- * Fig. 25-11 touches Fig. 25-12 which is rotating, and rotates one revolution.
- * Fig. 25-1, which is interlocked with Fig. 25-11, is pushed down.
- * Fig. 25-8, which is interlocked with Fig. 25-1, is pushed down and reforms an adequate loop.

1. Adjustment:

(1) Spring Link 1 (Fig. 25-3):

- * Set Main Knob at "⊙" position.
- * Adjust the position of Fig. 25-3 to keep approx. 1mm distance in (q) in Fig. 25 and fix Fig. 25-3 with Fig. 25-4.
- * Make certain that the distance (q) in Fig. 25 is maintained after Loop Restorer works several times.

(2) Holder Link (2) Assy (Fig. 25-5):

- * Shorten the length of the lower film loop by pulling up the upper film loop by finger, while feeding the film.
- * Adjust the position of Fig. 25-5 so that film may touch the lower end of Fig 25-7 before Fig. 25-8 starts rotating and that loop restorer may work smoothly.
- * In practice, push Fig. 25-5 up to the highest position and fix Fig. 25-6 slightly.
- * Shorten the length of lower film loop by finger so that film may be about to touch Fig. 25-8.
- * Then bring down Fig. 25-7 by hitting Fig. 25-5 slightly with screwdriver, etc. to the position that Loop Restorer starts working, and fix Fig. 25-6.

- * If Loop Restorer does not work at the time Fig. 25-7,8 vibrate even after the said adjustment, firstly adjust Fig. 25-7 so that it may smoothly move.
- * And loosen Fig. 8-14 and adjust the position of Fig. 8-12 (Sprocket) by turning it clockwise or counterclockwise. (Refer to H-1)
- * Be sure to check the function of Loop Restorer at both "M" and "0" reproductions.

Note: Loop Restorer should start working when about 20gr. pressure is given to the lower end of Fig. 25-7.

(3) Plate Guide Roller 3 (Fig. 25-13):

- * Fig. 25-8 forms the lower film loop when Main Knob is turned from "OFF" to "●" positions.
- * Adjust the position of Fig. 25-13 so that Fig. 25-8 may locate at the lowest position in order to form sufficient lower film loop.
- * In practice, adjust Fig. 25-13 by turning Fig. 25-14x2 and fix it with Fig. 25-15x2 at the position that Fig. 25-13 locates at the lowest position and that Fig. 25-13 moves smoothly.
- * Check and adjust the position of Fig. 25-13 so that, when turning Main Knob from "OFF" to "●", Fig. 25-8 may be set free after film is engaged in Sprocket.

Illustration No.	Parts No.	Parts Name	
1	4P31849	リンク(1)ループセッタ	Link (1) loop setter
2	4P31850B	リンク(1)スプロケットシュー	Link (1) sprocket shoe
3	4P55592	バネリンク(1)スプロケットシュー	Spring link 1
4	6M60300601	トラス小ネジ M630-5	Screw truss M630-6
5	P412129	ホルダ組立リンク(2)	Holder link (2) assy
6	6M70300401	六角穴止メネジ M30-3	Screw pan M730-4
7	P412202	リンク(2)ループセッタ	Link (2) loop setter
8	P412209	ガイドローラ(3)	Guide roller 3
9	P412352	レバー組立ループセッタ	Lever loop setter assy
10	P412352	レバー組立ループセッタ	Lever loop setter assy
11	P412237	摩擦車(2)ループセッタ	Friction wheel 2
12	P412270	ウォームギヤ(1)組立品	Worm gear (1) assy
13	P412206B	押エ板レバーガイドローラ(3)	Plate guide roller 3
14	4P55575	間座押エ板ガイドローラ(3)	Washer guide roller 3
15	6M7A400801	トラス小ネジ M640-6	Screw sems A M740-8

W. CLAW SECTION

1. Adjustment:

- (1) Adjust the attaching position of Fig. 12-14 so that Fig. 12-25 may smoothly rotate without end-play to (r) direction.
- (2) Adjust the pressure of Fig. 12-29 or replace Fig. 12-16,29 so that Fig. 12-16 may closely contact with Fig. 12-19 and may smoothly move.
- (3) Adjust the pressure of Fig. 12-30 so that Fig. 12-28 may always contact with Fig. 12-26.
- (4) Measure the tension to (s) direction in Fig. 12 at the attaching position of Fig. 12-18 by a tension guage.

Adjust the pressure of Fig. 12-30 so that the said tension may be 300gr.

The measurement and adjustment should be done without attaching Fig. 12-16.

- (5) Adjust the protrudent length of tip of Fig. 12-18 from Fig. 12-6 to be 1mm. Then Fig. 12-18 should be at the center of film perforations.
- (6) Adjust the attaching position of Fig. 12-5 or bend (y) in Fig. 12 so that momentums of a picture in the both directions may be equal. Then Fig. 12-1 should not only closely contact with (y) in Fig. 12 but also smoothly move.
- (7) Adjust the timing between Fig. 12-18 and 24 so that Fig. 12-24 may intercept the projection light when Fig. 12-18 feeds film. Make certain that picture does not flow.
- (8) Fig. 12-17,18 should be replaced as a unit because Fig. 12-18 is fixed to Fig. 12-17 tightly with adhesive.
- (9) Stroke of Fig. 12-18 is to be 7.65-7.67mm.

Use undeveloped film for check and adjustment of the stroke.

Just before Fig. 12-18 starts feeding the film, protrudence of Fig. 12-18 from Fig. 12-6 should be maximum, and two tips of Fig. 12-18 should be closest to the lower edge of film perforations. And when two tips of Fig. 12-18 go into and out film perforations, they should not touch film perforations.

To adjust the stroke, change the attaching position of Fig. 12-16 by enlarging its center hole with a reamer or file.

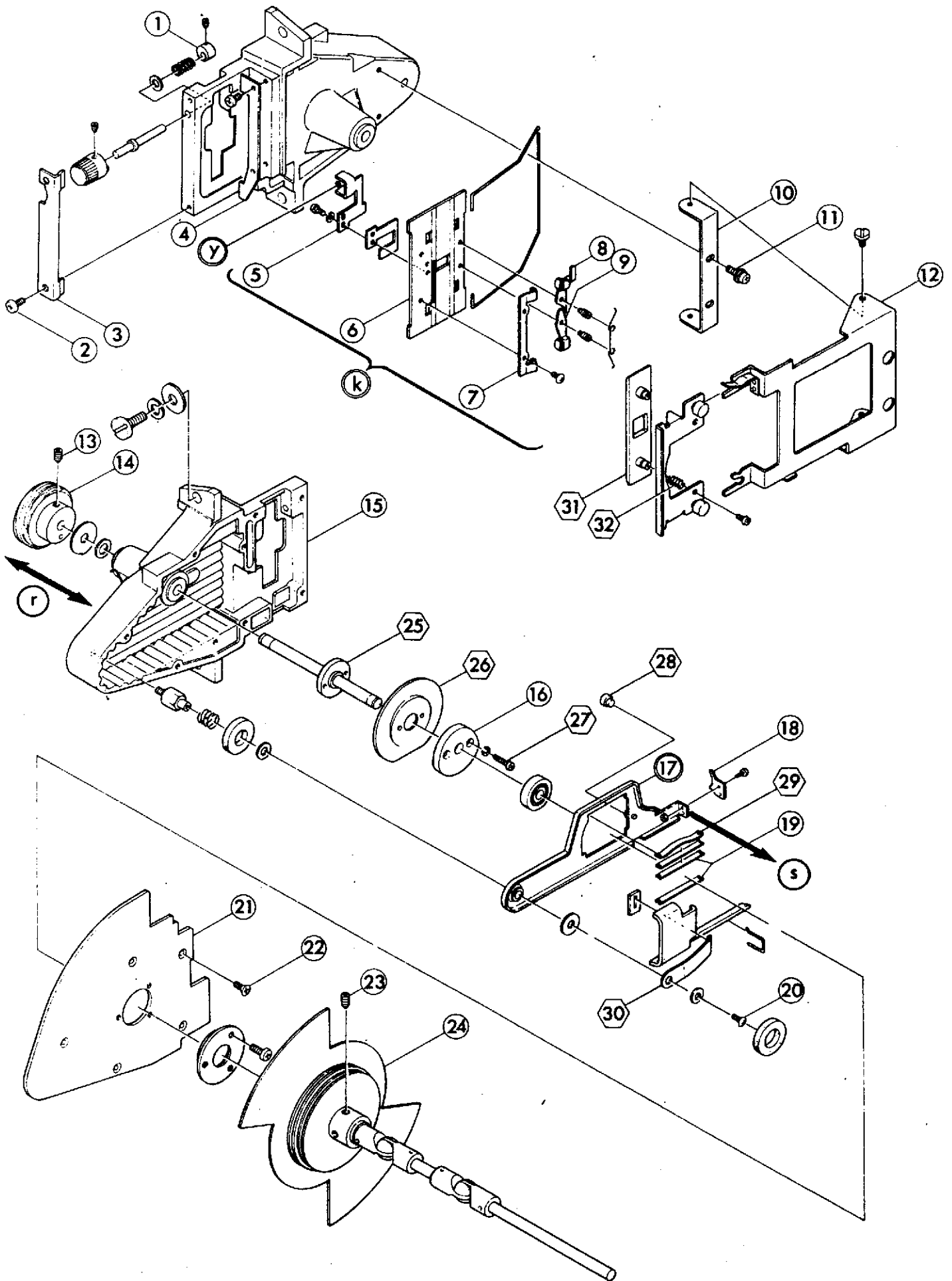

Fig. 12

For example, when the position of Fig. 12-16 is changed by $1/100\text{mm}$, the stroke of Fig. 12-18 becomes longer or shorter by $4/100\text{mm}$ (4 times of changed distance).

Shorter stroke than the proper one causes film jumping, and longer stroke causes loud feeding mechanism noise.

- (10) When attaching Fig. 12-21, apply Liquid Gasket (semidrying type) on contacting surfaces of Fig. 12-21,15.
- (11) When attaching Fig. 12-4, adjust the position of Fig. 12-4 so that Fig. 12-6 may closely contact with Fig. 12-4 and move smoothly.
- (12) When attaching Fig. 12-7, adjust the position of Fig. 12-7 so that the center of aperture opening of Fig. 12-6 may coincide correctly with that of film frame, using standard test film such as SMPTE TEST FILM 16RT RP20 (REGISTRATION TARGET).
- (13) Fig. 12-8,9 should work independently without any interference. So keep about 0.3mm clearance between Fig. 12-8 and 9 when film is loaded between Fig. 12-7 and 8,9.
- (14) Adjust Fig. 12-8,9,12 so that Fig. 12-8,9 may move as follows:

When Main Knob is set at "OFF" position, Fig. 12-8,9 move in the opposite direction of Fig. 12-7 for easy film loading.

When Main Knob is set at "●" or "◁" position, Fig. 12-8,9 move towards Fig. 12-7 to press the film-side.

X. SOUND BASE PLATE

1. Adjustment:

Adjust Sound Base Plate as follows:

(1) Location of Brake Roller 1 (Fig. 26-1):

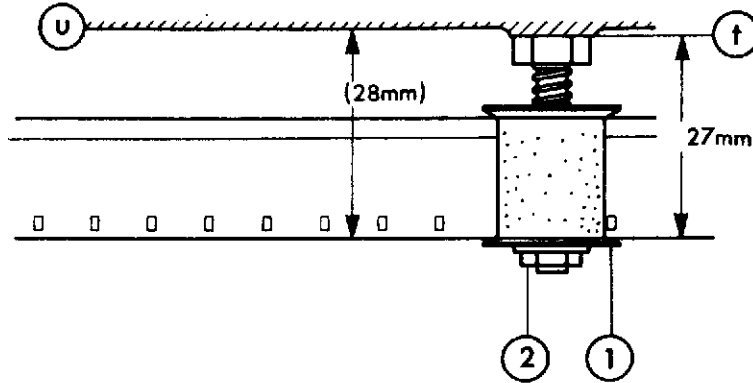

Fig. 26

Illustration No.	Parts No.	Parts Name	
1	P414947	制動ローラ(1)	Brake roller 3 assy
2	6NM19030F	特殊ナット M4.0	Special nut M3.0

Adjust the position of Fig. 26-1 to keep 27mm distance from the perforation-side end of film to the attaching mount of Fig. 26-1 ((t) in Fig. 26).
(To claw section and both sprockets, above 27mm distance is applied.)

In practice, adjust the position of Fig. 26-1 by turning special Nut M4.0 so that the distance from the perforation-side end of film to Base Frame ((u) in Fig. 26) may come to 28mm.

Note: Fig. 26-1 also functions as Impedance Roller and maladjustment of Brake Roller 1 gives bad influence upon Sound Quality (Wow & Flutter, etc.).

(2) Adjustment of Bazz Track:

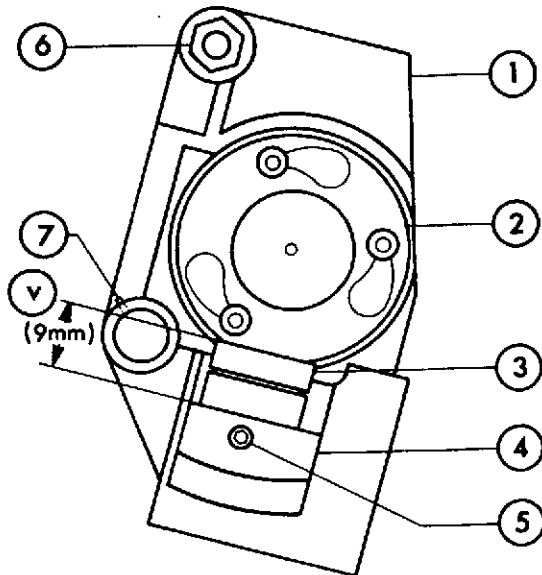

Fig. 27

Set the volume control at maximum position, and run a Bazz Test Film such as SMPTE TEST FILM (P16BT BUZZ TRACK).

Loosen Fig. 27-7 and adjust the position of Fig. 27-1 by turning Fig. 27-6 clockwise or counter-clockwise so that the level of output power may be minimized.

After the adjustment, tighten Fig. 27-7 and fix it by applying adhesive.

Illustration No.	Parts No.	Parts Name	
1	P412050	ホルダエキサイタランプ	Holder exciter lamp
2	4E41580	エキサイタランプ KE-04 4V-0.75A	Exciter lamp KE-04 4V-0.75A
3	4P31862	サウンドレンズ組立品	Sound lens assy
4	P412233	ホルダサウンドレンズ	Holder sound lens
5	6MT4300305	六角穴止メネジ M30-3	Set screw hexagon M30-3
6	6NM19040F	特殊ナット M4.0	Special nut M4.0
7	6M7020040	止メネジ M20-2.5	Screw pan M720-4

(3) Adjustment of Azimuth for Optical Reproduction:

Load 7,000Hz Test Film such as SMPTE TEST FILM (P16SFA SOUND FOCUSING) and set Main Knob at "●" position.

First, adjust the protrudent length of Fig. 27-3 from Fig. 27-4 to be about 9mm ((v) in Fig. 27).

Adjust the position of Fig. 27-4 by turning Fig. 27-3 so that the maximum output power may be obtained, and fix Fig. 27-3 by tightening Fig. 27-5.

Do not move Fig. 27-4 as it is originally fixed at correct position, using standard optical axis gauge.

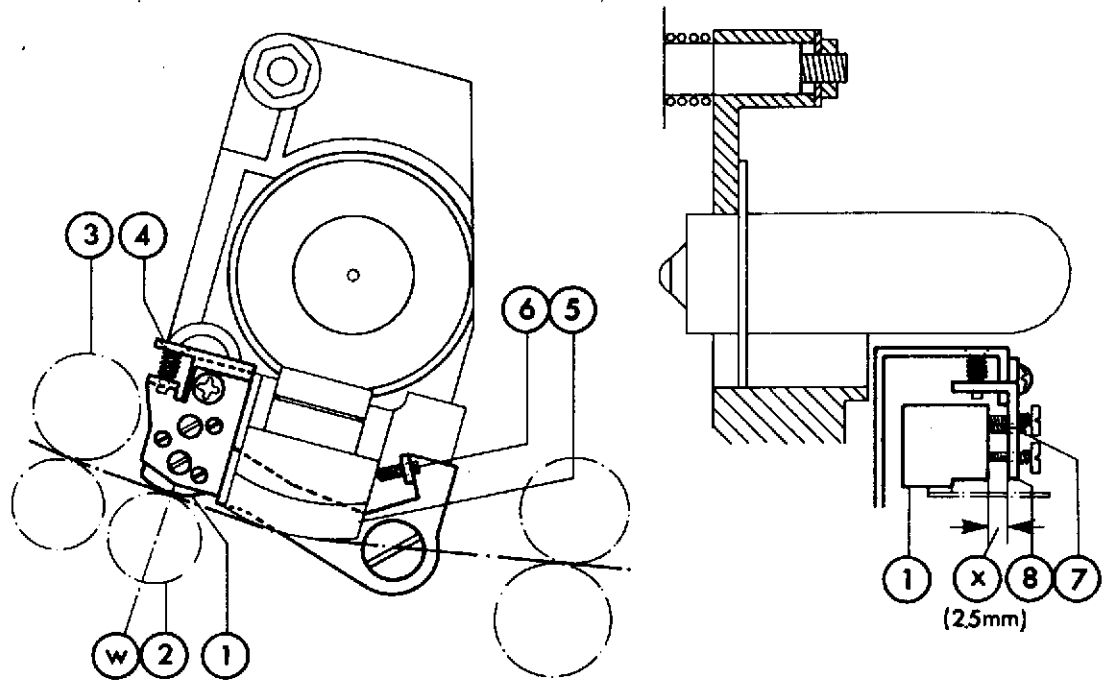

Fig. 28

Illustration No.	Parts No.	Parts Name	
1	4E42473	録音再生ヘッド WY-020	Sound head MH16
2	P412114	パッドローラ組立品	Pad roller assy
3	P412107	軸組立フライホイール	Shaft fly wheel assy
4	6M71200701	ナベ小ネジ M712-7	Screw pan M712-7
5	P412251	フィルムガイドホルダサウンドレンズ	Film guide sound lens
6	6M71200701	止メネジ M02-6	Screw pan M720-7
7	6MT0200601	止メネジ M02-6	Set screw M02-6
8	P412543	取付板ヘッド	Holder head

(4) Adjustment of Azimuth of Magnetic Recording/Playback Head:

- * Adjust the position of Fig. 28-1 so that Fig. 28-1 may position about 0.2mm lower from the assumed film path.

In practice, put a plastic ruler on Fig. 28-3 and 5, and adjust Fig. 28-1 by turning Fig. 28-6 so that Fig. 28-1 may slightly touch the ruler.

Next, move Fig. 28-1 about 0.2mm towards Fig. 28-2 by turning Fig. 28-6 counterclockwise.

Note: Unless Fig. 28-1 is fixed at proper position, it causes the below-mentioned troubles and gives bad influence upon Sound Quality (Wow/Flutter, Frequency Response, etc.).

- (a) Film sags
- (b) Untouch or unstable head-touch of Sound Track

So use best care to keep proper position of Fig. 28-1.

- * Adjust the position of Fig. 28-1 by turning Fig. 28-4 so that the center of Fig. 28-1 may coincide with the center line of Fig. 28-2 ((w) in Fig. 28).
- * Adjust the distance between Fig. 28-1 and 8 ((x) in Fig. 28) to be about 2.5mm by turning Fig. 28-7x3, and load a film.

Readjust the position of Fig. 28-1 by turning Fig. 28-7x3 slightly so that Fig. 28-1 may locate at the correct position against magnetic sound track.

Make certain that Fig. 28-1 may not interfere with picture.

- * Running 7,000Hz Test Film such as SMPTE TEST FILM (M16AL AZIMUTH ALIGNMENT, 7,000HZ), adjust the position of Fig. 28-1 by turning Fig. 28-7x3 so that the maximum output power may be achieved.

After the adjustment, fix Fig. 28-7x3 with adhesive.

III. TROUBLE SHOOTING

TAKE-UP & FEED REEL ARMS

Case	Checking Point	Step	Ref.
Take-up torque is insufficient	Belt Take-up Arm (Fig.2-59)	If Fig.2-59 is defective, replace it.	B, S
	Brake Spring Take-up (Fig.2-50)	If the pressure of Fig.2-50 is insufficient, increase it.	B
	Shaft Take-up Assy (Fig.2-58)	If the friction of Fig.2-58 is not proper, replace it.	S
	V Belt Take-up (Fig.2-11)	If the tension of Fig.2-11 is insufficient, increase it	B
	Rewind Square Shaft Assy (Fig.3-3)	If the friction of Fig.3-3 is not proper, adjust it by Fig.3-5 or replace Fig.3-4.	C
Film hangs down in front of the Projection Lens during projection or when projection is stopped.	Synchronous Belt 206 (Fig.3-4)	If the tension of Fig.3-4 is insufficient, increase it.	C
	Brake Spring Rewind (Fig.3-12)	If the pressure of Fig.3-12 is insufficient, increase it.	Fig.3
	(b) in Fig.4	If (b) in Fig.4 sticks to the shaft, remove stains from them.	Fig.4
Rewinding torque is insufficient.	Synchronous Belt 206 (Fig.3-4)	If the tension of Fig.3-4 is insufficient, increase it.	C
	Brake Spring Rewind (Fig.3-12)	If the pressure of Fig.3-12 is insufficient, increase it.	Fig.3
	Take-up Arm Assy (Fig.2-1)	If the rewinding friction is too strong, reduce it.	S
	Magnet Clutch (Fig.4-9)	Adjust the slip of Fig.4-9.	T
	Spring Friction Plate (Fig.21-3)	If the pressure of Fig.21-3 is insufficient, increase it.	T

CLAW SECTION & MACHINE FRAME

Case	Checking Point	Step	Ref.
Film Jumping	Claw Assy (Fig.12-17)	Adjust the position of Fig.12-18 against Fig.12-6.	W
		Adjust the pressure of Fig.12-30.	W
	Triangle Cam (Fig.12-16)	Adjust Fig.12-19 so that Fig.12-16 may closely contact with Fig.12-19 and also smoothly move.	W
	Triangle Cam Shaft Assy (Fig.12-25)	Adjust the position of Fig.12-14 so that Fig.12-25 may closely contact with Fig.12-15 and also smoothly rotate.	W
	Aperture Plate (Fig.12-6)	Check the flatness of Fig.12-6. If not flat, replace it.	Fig. 12
	Pressure Plate Assy (Fig.12-31)	Adjust the pressure of Fig.12-31 by changing the pressure of Fig.12-32.	W
		Adjust the position of Fig.12-12 so that Fig.12-31 may keep correct position against Fig.12-6.	Fig. 29
Film Side Pressure (1),(2) (Fig.12-8,9)	Adjust the spring effects of Fig.12-8,9 and the relation between them.	W	
Picture Flow	Shutter (1) Assy (Fig.12-24)	Adjust the timing between Fig.12-24 and 18.	W
Film Flow	Claw 2 (Fig.12-18)	Adjust the protrudent length of tip of Fig.12-18 from Fig.12-6 to be 1mm.	W
		Adjust Fig.12-18 to keep correct position against film perforation. If Fig.12-18 is damaged, replace it.	W Fig. 12
	Triangle Cam (Fig.12-16)	If the claw does not have specified stroke, adjust the attaching position of Fig.12-16 or replace it.	W
	Film Side Pressure (1),(2) (Fig.12-8,9)	Adjust the spring effects of Fig.12-8,9 and the relation between them.	W Fig. 29
	Pressure Plate Assy (Fig.12-31)	Make certain that Fig.12-31 closely contacts with Fig.12-6.	W

CLAW SECTION & MACHINE FRAME (Cont'd)

Case	Checking Point	Step	Ref.
Loud Feeding Noise	Triangle Cam (Fig.12-16)	Adjust the stroke of claw by changing the attaching position of Fig.12-16 or by replacing it.	W
	Claw 2 (Fig.12-18)	Adjust Fig.12-18 so that Fig.12-18 may make a right angle with film perforation by bending the free-end of Fig.12-17.	W
	Slide Plate Claw (Fig.12-19)	Adjust Fig.12-19 so that Fig.12-16 may closely contact with Fig.12-19 and also smoothly move.	W
	Spring Claw (Fig.12-30)	Adjust the pressure of Fig.12-30.	W
Masking	Masking Guide (Fig.12-5)	Adjust Fig.12-5 so that Fig.12-1 may closely contact with (y) in Fig.12 and also smoothly move.	W
Film Scratching	Aperture Plate, etc. (Fig.12-6), etc.	Check all parts which contact with loaded film. They should be neither injured nor stained.	
Upper Film Loop increases in length	Claw 2 (Fig.12-18)	If claw does not feed the film smoothly because of short protrudent length of tip of Fig.12-18, adjust the protrudent length to be 1mm.	W
Upper Film Loop decreases in length	Lever Guide Roller 2 (Fig.24-8)	Adjust Fig.24-8 to work properly.	U
	Cog First Sprocket (Fig.8-5)	Adjust Fig.8-5 so that Fig.8-5 may coincide with the center of film perforation.	U
Lower Film Loop decreases in length	Claw 2 (Fig.12-18)	Adjust the protrudent length of tip of Fig.12-18 from Fig.12-6 to be 1mm.	W
	Link (2) Loop Setter (Fig.25-7)	Adjust Loop Restorer so that it may work properly.	O

PROJECTION LAMP & LENS

Case	Checking Point	Step	Ref.
Lamp does not light	Lamp (Fig.13-1)	If lamp itself is defective, replace it.	Fig.13
	Lamp Socket QEX-7 (Fig.13-2)	If Fig.13-2 has insufficient contact, replace it.	Fig.13
	Lamp Switch S4	If S4 is defective, replace it.	Fig.15 30 31
	Lamp Switch S6 (Fig.15-4)	If Fig.15-4 is defective, replace it.	Fig.15 30 31
	Transformer (1) Assy (Fig.15-3)	If Fig.15-3 is defective, replace it.	P
Dark Image	Lamp (Fig.13-1)	If brightness is not enough due to long-use, replace Fig.13-1.	Fig.13
	Lamp Socket QEX-7 (Fig.13-2)	Adjust the position of lamp by moving Fig.13-2. If the terminal voltage of Fig.13-2 is less than the rated value, check Fig.15-3, etc. and replace the defective parts.	Fig.13
Uneven Screen Brightness	Lamp Socket QEX-7 (Fig.13-2)	Adjust the position of Fig.13-2 so that most bright and leveled screen brightness may be achieved.	Fig.13
Uneven Screen Focusing	Aperture Plate (Fig.12-6)	Adjust the position of Fig.12-6 so that Fig.12-6 may be attached to Fig.12-15 properly and also film may be pressed to Fig.12-6 properly by Fig.12-31. (Film should closely contact with Fig.12-6)	Fig.12
	Holder Projection Lens (Fig.13-12)	If correct optical axis cannot be achieved due to damaged Fig.13-12, replace it.	Fig.13

MOTOR & TRANSFORMER

Case	Checking Point	Step	Ref.
Projector does not run.	Power Cord, Main Fuse (F1)	If Power Cord or Main Fuse is defective, replace it.	Fig. 30 31
	Transformer (1) Assy (Fig.15-3)	If the terminal voltage of Fig.15-3 which is applied to motor is less than the rated value (100V), replace it.	"
	Motor Switch (S1, S2, S3)	If motor switch is defective, replace it.	"
	Starting Condenser (CM1, CM2)	If starting condenser or resistor is defective, replace it.	"
	Relay (RY)	If relay is defective, replace it.	"
	Motor	If motor is defective (insufficient torque, broken wire, etc.), replace it.	0
Projector runs slowly.	Transformer (1) Assy (Fig.15-3)	If the terminal voltage of Fig.15-3 which is applied to motor is less than the rated value (100V), replace it.	Fig. 30 31
	Motor	If motor torque is insufficient, replace it.	0
	Pulley (1) Motor (Fig.14-7)	If slip occurs between Fig.14-1 and 7, adjust it.	0
	V Belt Main 3M375 (Fig.14-1)	If the tension of Fig.14-7 is too tight, adjust it.	0
	Claw Section, etc.	Adjust the load at main parts such as Claw Section, if over-loaded.	
Projector does not run inversely.	Motor Switch (S2, S3)	If motor switch is defective, replace it.	Fig. 30 31

SOUND

Case	Checking Point	Step	Ref.
Neither Optical nor Magnetic Film can be reproduced.	Power Cord, Fuse (F1)	If power cord or fuse is defective, replace it.	Fig.30 31
	Amplifier Fuse (F2)	If amplifier fuse is defective, replace it.	"
	Transformer (1) Assy (Fig.15-3)	If the terminal voltage of Fig.15-3 which is applied to Amplifier is less than the rated voltage (29V) due to broken wire, etc., replace Fig.15-3.	"
	Speaker 8 ohms (Fig.4-6)	If Fig.4-6 is defective, replace it.	Fig.4
	Connector (CN1-5,7,8; CN2-1,2,3,4,5), Switch (SW1-2, SW2-1)	Check the conduction of connectors and switches. If not conduct, replace it.	Fig.31 32
	Amplifier	Check the voltages in comparison with the voltage checking points. If the unusual voltage would be measured, replace amplifier.	Fig.29
	REC1	If REC1 is defective, replace it.	Fig.32
Optical Film cannot be reproduced.	Exciter Lamp (Fig.27-2)	If Fig.27-2 is defective, replace it.	
	Fuse (F3), Connector (CN1-9,10,11), Switch (SW1-3, SW2-2)	Check the conduction of fuse, connectors and switches. If not conduct, replace it.	Fig.31 32
	REC2, Exciter Lamp Circuit	If REC2 or exciter lamp circuit is defective, repair or replace it.	Fig.32
	Amplifier	Check the voltages in comparison with the voltage checking points. If the unusual voltage would be measured, adjust or replace amplifier.	Fig.29
	Sound Lens (Fig.27-3)	If Fig.27-3 is dusty or defective, brush away dust or replace it. If Fig.27-3 is out of position, adjust it.	X
	Silicon Photo Diode (Fig.17-7)	If Fig.17-7 is dusty or defective, brush away dust or replace it. If Fig.17-7 is out of position, adjust it.	Q
	Knob M-0 Switch (Fig.1-7)	If Fig.1-7 is defective, replace it.	A, R

SOUND (Cont'd)

Case	Checking Point	Step	Ref.
Output level is low at Optical reproduction.	Amplifier	Check the voltages in comparison with the voltage checking points. If the unusual voltage would be measured, adjust or replace amp.	Fig. 29
	Sound Lens (Fig.27-3)	If the attaching position of Fig.27-3 is not proper, adjust it by using 7,000Hz Test Film. Remove stains from the surface of sound lens.	X
	Exciter Lamp (Fig.27-2)	If the attaching position of Fig.27-2 is not correct, adjust it. If Fig.27-2 is defective, replace it.	X
Magnetic Film cannot be reproduced.	Sound Head WY-020 (Fig.28-1)	If Fig.28-1 is defective (broken wire, etc.), replace it.	X
	Canceling Coil L1	If canceling coil is defective, replace it.	Fig. 32
	Connector (CN2-3,4)	Check the conduction of connectors. If not conduct, replace it.	Fig. 31 32
	Knob M-0 Switch (Fig.1-7)	If Fig.1-7 is defective, replace it.	A,R
	Amplifier	Check the voltages in comparison with the voltage checking points. If the unusual voltage would be measured, adjust or replace amp.	Fig. 29
Output Sound is low at Magnetic reproduction	Sound Head WY-020 (Fig.28-1)	If Fig.28-1 is worn out by long use, replace it.	X
	Amplifier	Check the voltages in comparison with the voltage checking points. If the unusual voltage would be measured, adjust or replace amp.	Fig. 29
Amplifier Noise	Canceling Coil L1 (Magnetic Reproduction)	If canceling coil is out of position, adjust it.	Fig. 32
	Silicon Photo Diode (Fig.17-7) (Optical Reproduction)	If Fig.17-7 vibrates, adjust amp. so as not to vibrate.	Q
	Amplifier	If parts in amplifier is defective, replace it.	

SOUND (Cont'd)

Case	Checking Point	Step	Ref.
Wow & Flutter (Magnetic & Optical reproduction)	Sprocket (Fig.8-12)	If Fig.8-12 touches film perforation-side, adjust the position of it. If Fig.8-12 has defective such as distortion or disfigurement, replace it.	E,X
	Shaft FlyWheel Assy (Fig.17-1)	If Fig.17-1 has defective such as disfigurement or eccentricity, replace it.	Q
		If there is end-play in Fig.17-1, adjust it by turning Fig.17-14.	Q
		If there is unnecessary clearance between Fig.17-1 and Fig.17-4,13 due to defect of Fig.17-4 or 13, replace Fig.17-4 or 13.	Q
		If Fig.17-1 does not rotate smoothly, adjust Fig.17-14 or replace Fig.17-14,13.	Q
	Worm 2 (Fig.11-4)	If Fig.11-4 has disfigurement, replace it.	L
		If there is end-play in Fig.11-4, adjust it by moving the position of Fig.11-5.	L
		If Fig.11-4 unnecessarily moves in right-angled direction against axis, replace Fig.11-3,7.	L
	Worm Gear (2) Assy (Fig.8-8)	If Fig.8-8 has defective such as distortion or disfigurement, replace it.	E
	Fly Wheel Spring (Fig.16-14)	If the pressure of Fig.16-14 is insufficient, increase it.	Q
	Belt Take-up Arm (Fig.2-4)	If take-up tension is unstable, replace Fig.2-4.	B
	V Belt Take-up (Fig.2-11)	If the tension of Fig.2-11 is not enough and Fig.2-11 slips, increase the tension of Fig.2-11.	B
	Brake Roller 1 (Fig.26-1)	If Fig.26-1 does not rotate smoothly, adjust it.	X
If Fig.26-1 has eccentricity, replace it.		X	
(1) in Fig. 14	If vibration of motor and Fig.14-9 are too big, adjust or replace them.	0	

SOUND (Cont'd)

Case	Checking Point	Step	Ref.
Wow & Flutter (Magnetic Reproduction)	Sound Head WY-020 (Fig.28-1)	If position of Fig.28-1 is not correct, adjust the position by turning Fig.28-6.	X
	Pad Roller Assy (Fig.28-2)	If Fig.28-2 is defective, replace it.	X
		If Fig.28-2 does not rotate smoothly or the pressure to Fig.28-1 does not become stable, adjust it.	X
Wow & Flutter (Optical Reproduction)	Silicon Photo Diode (Fig.17-7)	If Fig.17-7 vibrates, adjust amplifier so as not to vibrate.	Q

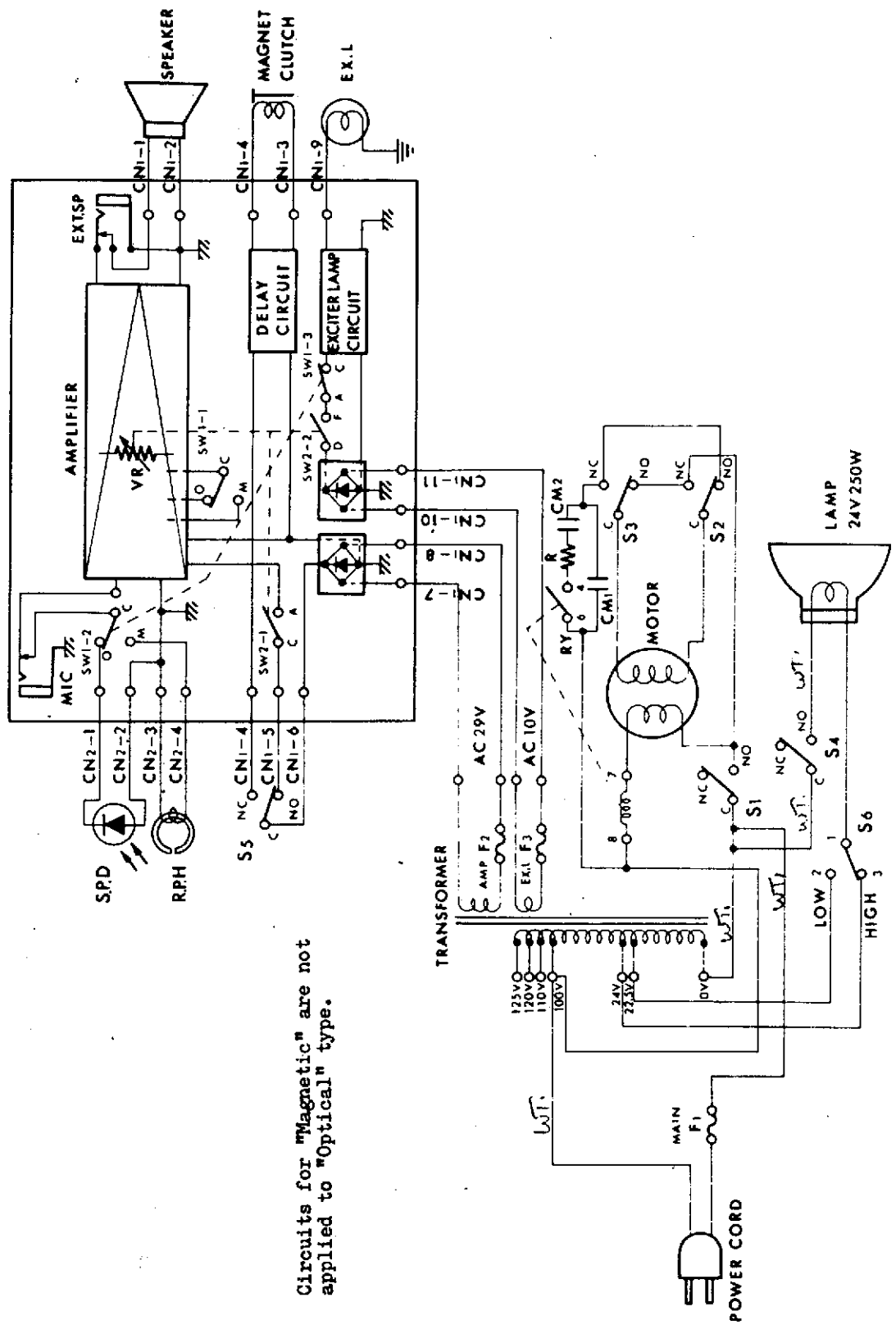

Circuits for "Magnetic" are not applied to "Optical" type.

SCHEMATIC DIAGRAM FOR MACHINE FOR ELMO 16-CL (M-O & O) E31007

ELECTRIC PARTS LIST

E30983

Item	Parts No.	Parts Name	Circuit Diagram No.	Item	Parts No.	Parts Name	Circuit Diagram No.
IC	5ALD3115	IC (LD3115)	IC1	200K Ω	5R1C002541	C film fix R. 200K Ω ½W	R5
	5ALD3141	(LD3141)	IC2				
Tr	5ATA7210P	(TA7210P)	IC3	30PF	5DQ0310511	Ceramic con. 30PF/50WV	C20
	5S12SC945	Transistor (2SC945)	Tr1	47PF	5DQ4700511	47PF/50WV	C6
D	5S12SC1098	(2SC1098)	Tr2	500PF	5DQ0520511	500PF/50WV	C1
	5S2RD62E	Zener diode (RD6.2E)	D1	1000PF	5DJ0130511	Polyest film 1000PF/50WV	C9 C23
REC	5S2SR1K2	Si diode (SR1K-2)	D2	2000PF	5DJ0230511	2000PF/50WV	C2
	5S2S1RBA20	Si rectifier (S1RBA20)	REC 1 REC2	4700PF	5DJ4720511	4700PF/50WV	C8
VR	5R4Z0014A1	VR 10K A-type+10K B-type	VR	6800PF	5DJ6820511	6800PF/50WV	C26
				0.01MF	5DJ0140511	0.01MF/50WV	C11
0.47 Ω	5R5B047K71	Metal film R. 0.47 Ω 2W	R16	0.022MF	5DJ2230511	0.022MF/50WV	C14
1.5 Ω	5R1C015141	C film fix R. 1.5 Ω ¼W	R17	0.033MF	5DJ3330511	0.033MF/50WV	C12 C13
5.1 Ω	5R2B051J81	Cement R. 5.1 Ω 5W	R23 R24	0.1 MF	5DJ0150514	0.1MF/50WV	C25
22Ω	5R1C022042	C film fix R. 22Ω ¼W	R15	0.15MF	5DJ1540511	0.15MF/50WV	C27
100Ω	5R5B001271	Metal film R. 100 Ω 2W	R25	1MF	5DB0163501	Al elect con. 1MF/35WV	C10 C19
560 Ω	5R5B056171	560 Ω 2W	R22	4.7MF	5DB4753502	4.7MF/35WV	C21
1 K Ω	5R5B001371	1K Ω 2W	R26	10MF	5DG0170111	Ta solid con. 10MF/10WV	C3
1.5 K Ω	5R1C001341	C film fix R. 1K Ω ¼W	R18	47MF	5DB4760111	Al elect con. 47MF/10WV	C7
	5R1C015241	1.5K Ω ¼W	R14		5DB01863J1	100MF/6.3WV	C15 C16
1.8 K Ω	5R5B018261	Metal film R. 1.8K Ω 1W	R9	100MF	5DB0182501	100MF/25WV	C4 C5 C17 C18
2 K Ω	5R1C002341	C film fix R. 2K Ω ¼W	R1		5DB0180511	100MF/50WV	C24
3 K Ω	5R1C003341	3K Ω ¼W	R19	220MF	5DB2270111	220MF/10WV	C29
5.6 K Ω	5R1C056241	5.6K Ω ¼W	R10		5DB2272501	220MF/25WV	C22
10 K Ω	5R1C001441	10K Ω ¼W	R6 R7 R12	1000MF	5DB0193501	1000MF/35WV	C28
12 K Ω	5R1C012342	12K Ω ¼W	R3		5DB0190511	1000MF/50WV	C30 C33
18K Ω	5R1C018342	18K Ω ¼W	R4	3300MF	5DB3380111	3300MF/10WV	C32
27K Ω	5R1C027341	27K Ω ¼W	R20		5DB3381601	3300MF/16WV	C31
50K Ω	5R1C005441	50K Ω ¼W	R21				
51K Ω	5R1C051341	51K Ω ¼W	R8				
100K Ω	5R1C001541	100K Ω ¼W	R2 R11 R13				

*Metal film R. Metal film fixed resistor * C film fix R. Carbon film fixed resistor * con. condenser * Polyester Polyester * Al elect. Aluminum electrolytic * Ta Tantalum

STANDARD VALUE OF PRESSURE

When measuring pressures, set Main Knob at "P" position.
 When measuring pressure at (e), put two sheets of films between Sprocket and Roller Sprocket. And measure it, while pulling out films.

a.	(P412350)	45 ± 10 gr.	h.	(P410607)	80 ± 20 gr.
b.	(P412349)	230 ± 70 gr.	i.	(P412114)	250 ± 50 gr.
c.	(P412345)	50 ± 10 gr.	j.	(P412112)	50 ± 20 gr.
d.	(P412346)	55 ± 15 gr.	k.	(P412368)	370 ± 70 gr.
e.	(P412338)	350 ± 100 gr.	l.	(P412339)	200 ± 50 gr.
f.	(P412209)	40 ± 20 gr.	m.	(P412112)	370 ± 100 gr.
g.	(P412114)	50 ± 10 gr.	n.	(4P31886)	65 ± 15 gr.

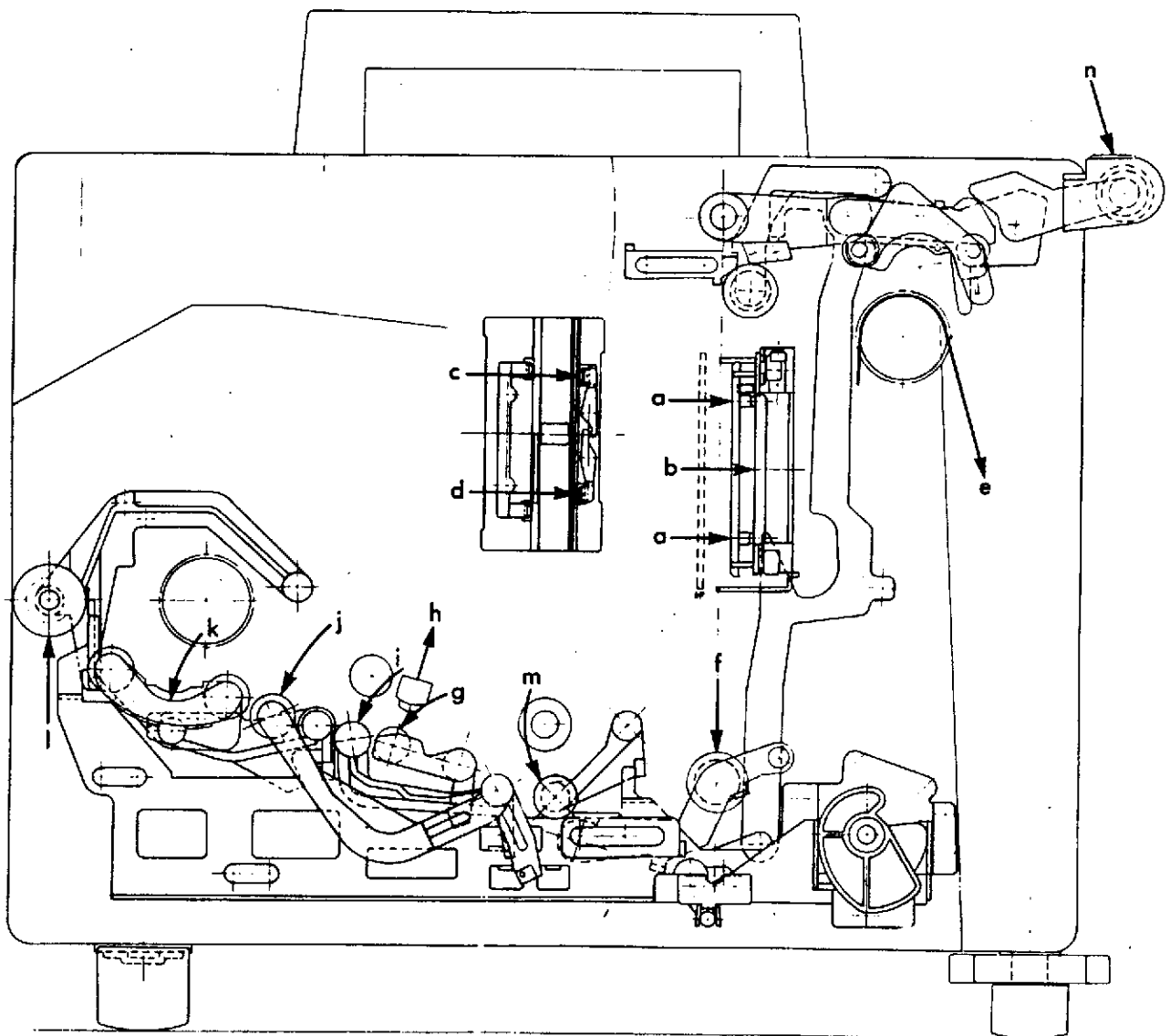

Fig. 29

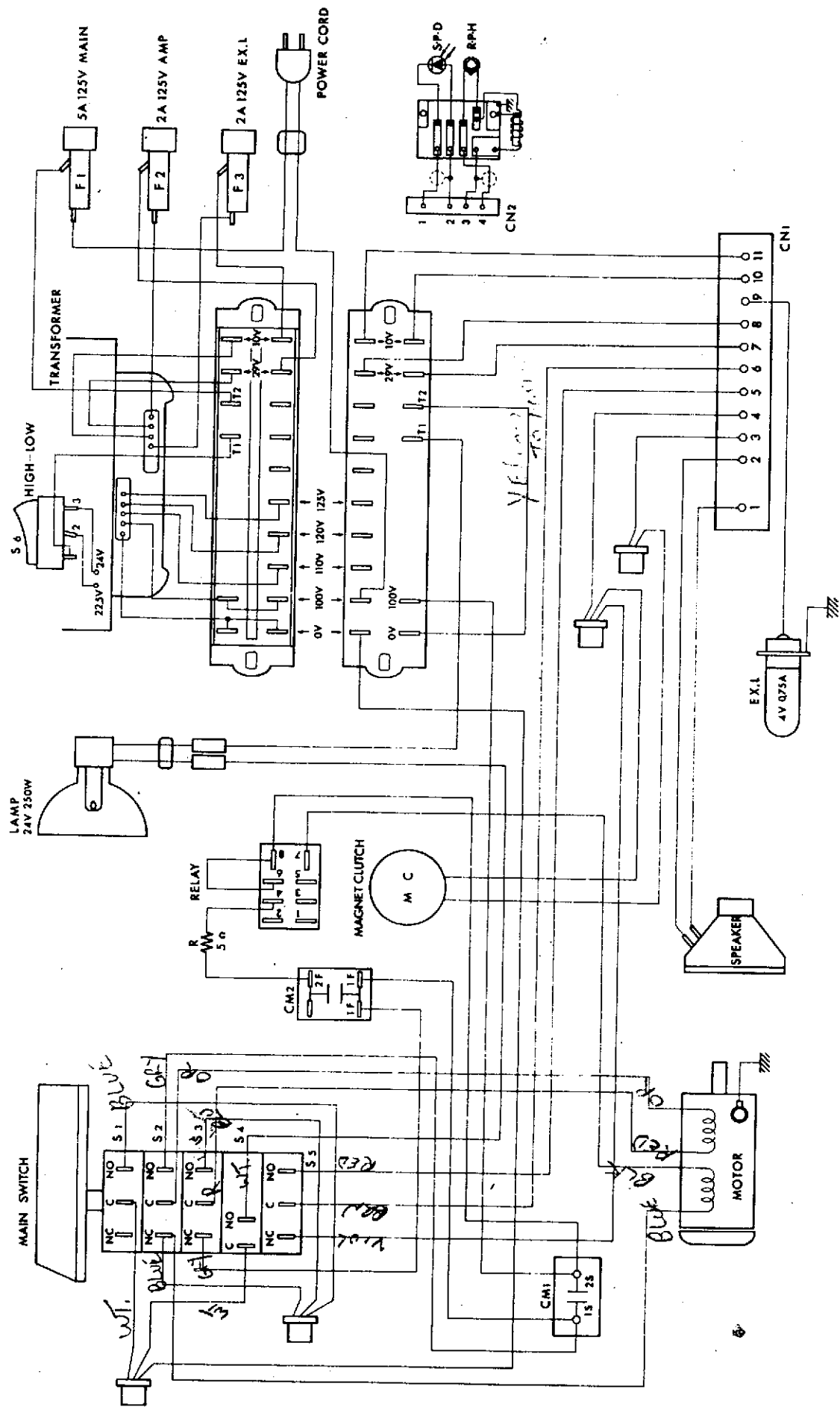

Fig. 30 Connecting diagram for machine for 16-CL

F 31005

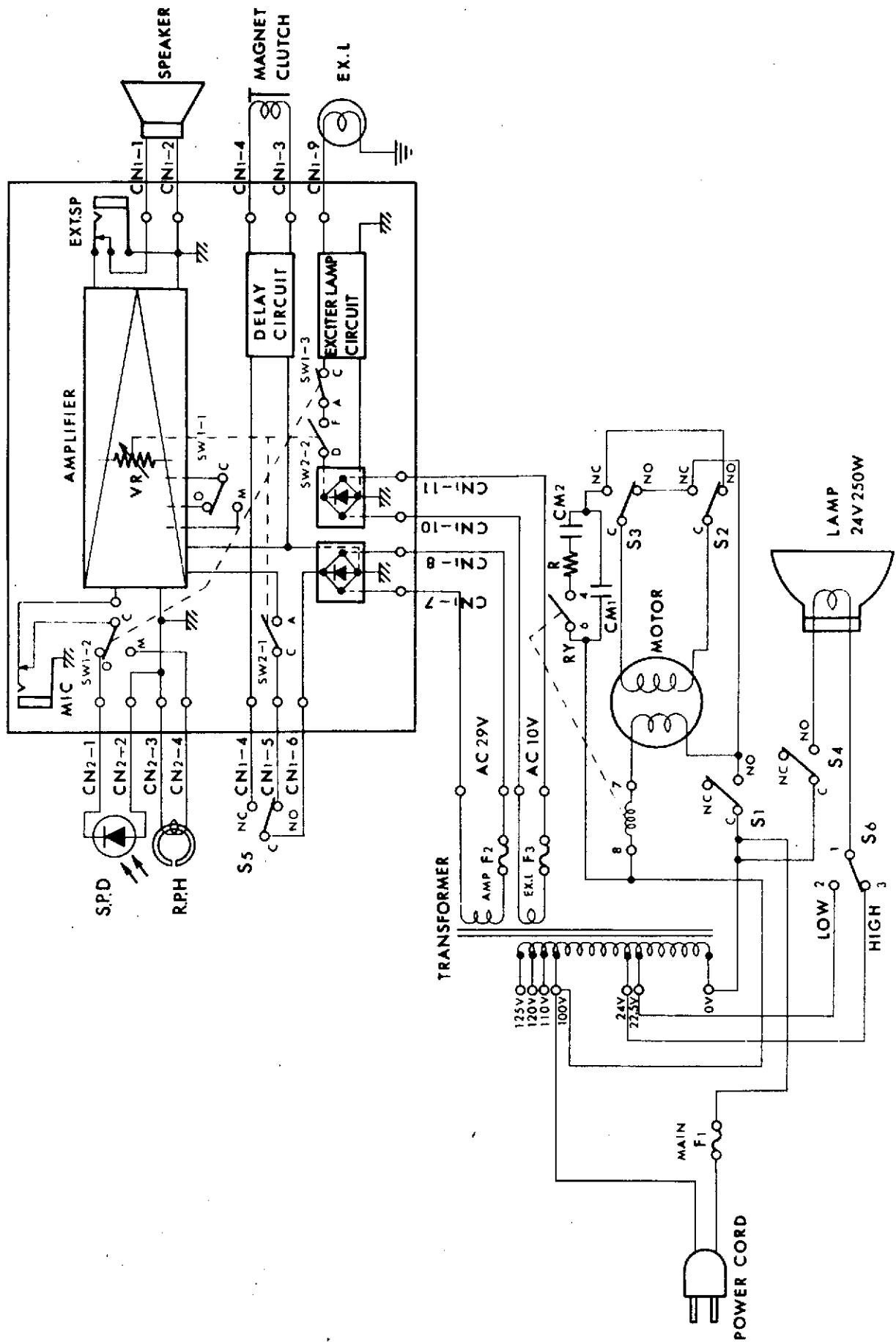
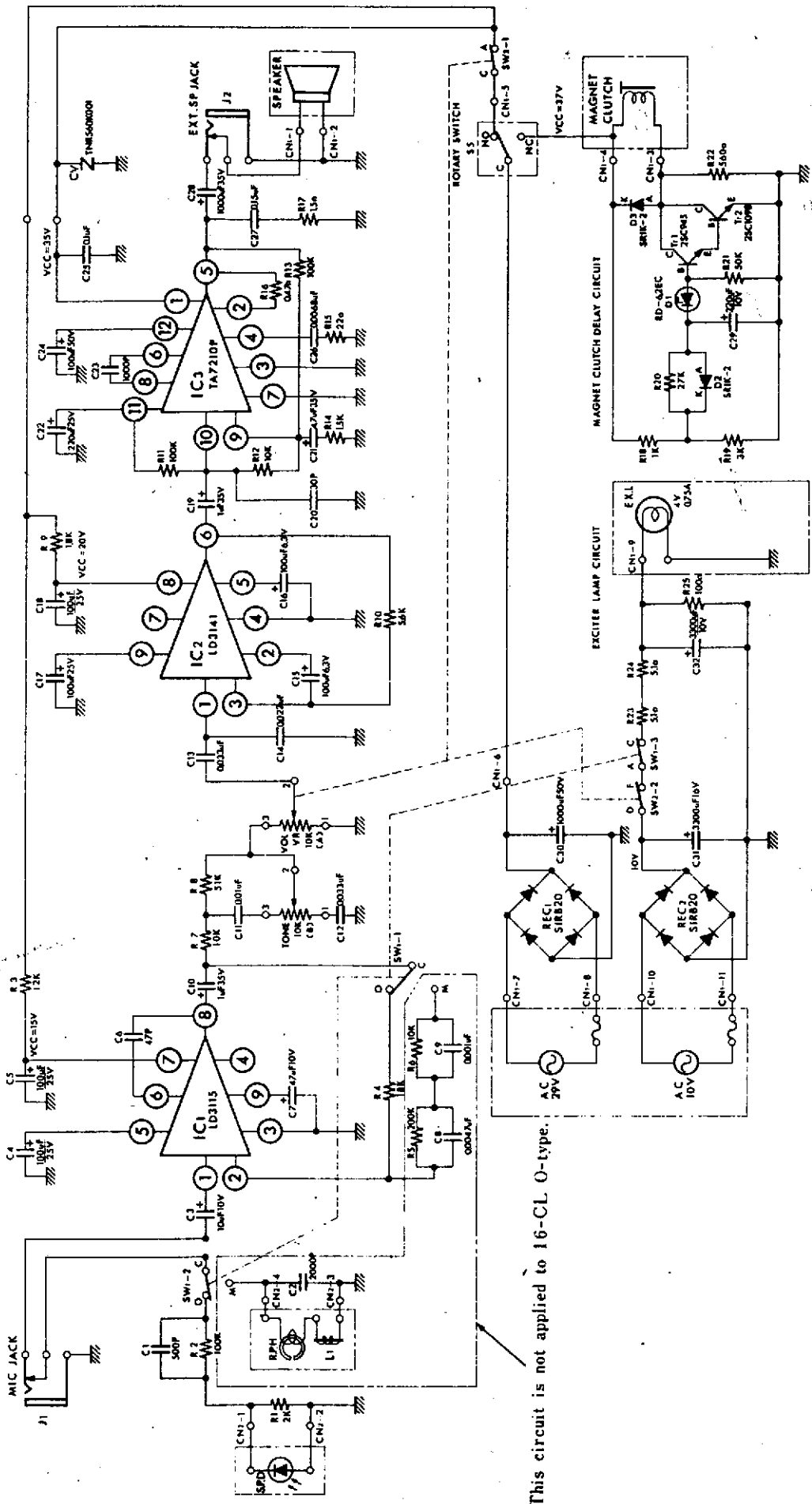

Fig. 51 Schematic diagram for machine for 16-CL

E31007

EXC LAMP POSS. IC4

See BLUE SK-1



This circuit is not applied to 16-CL O-type.

Fig. 32 Schematic diagram for amplifier for 16-CL

E30983

*Measure the voltage at each checking point by Vacuum-tube Voltmeter.

Values surrounded by \square are specified voltages measured under following steps.

1. Turn Volume Control Knob fully clockwise.
2. Set Tone Control Knob at the center position.
3. Apply 4.8mV-400Hz signal oscillated by Oscillator to Mic. receptacle (Fig.33,J2).
4. Set Volume Control Knob so that the output level measured by Vacuum-tube Voltmeter may be 11.5dB lower than its maximum level.

If use a Tester instead of Vacuum-tube Voltmeter, be sure to use one whose internal impedance is more than 1 Kohms/volt at AC.

*Other voltages mentioned in this circuit diagram are DC voltages when no signal is applied. If use a Tester, be sure to use one whose internal impedance is more than 10 Kohms/volt at DC.

*If the internal impedance is less than the above-mentioned value, proper value would not be measured.

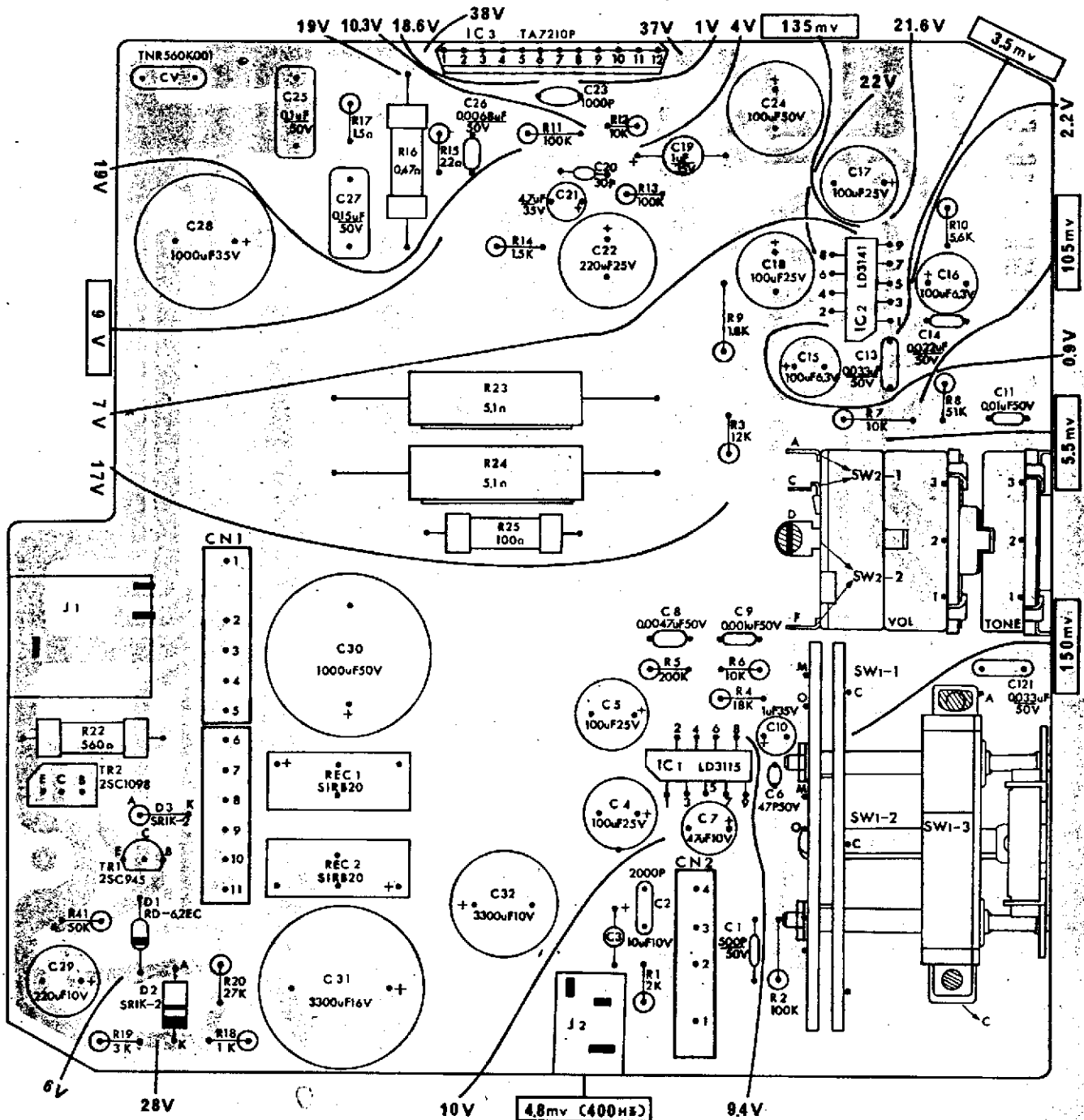
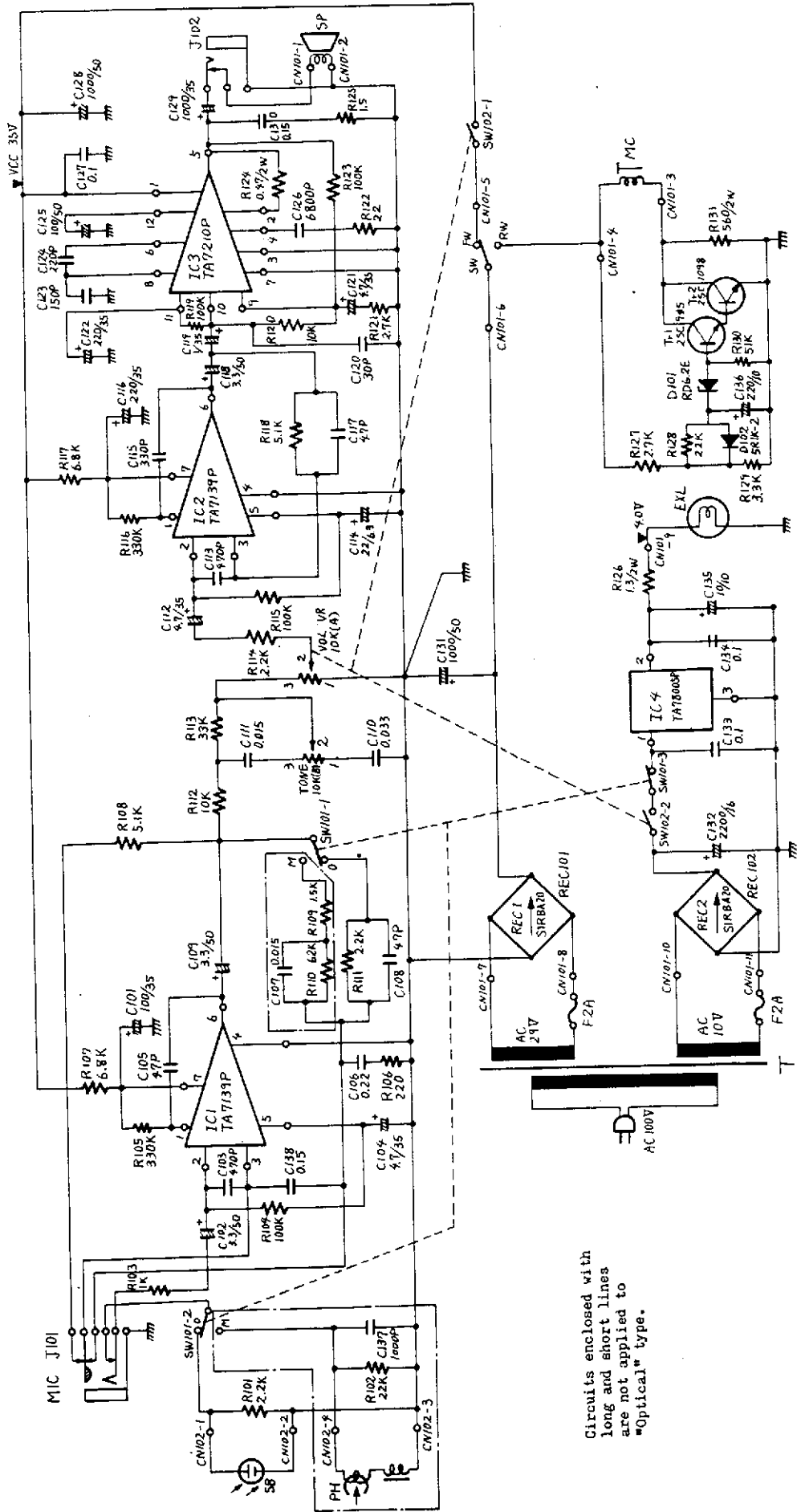

Fig. 33 Amplifier circuit plate for 16-CL

E20454



Circuits enclosed with long and short lines are not applied to "Optical" type.

SCHMATIC DIAGRAM FOR AMPLIFIER FOR ELMO 16-CL (M-080) E31503
(NEW TYPE E20667 printed)

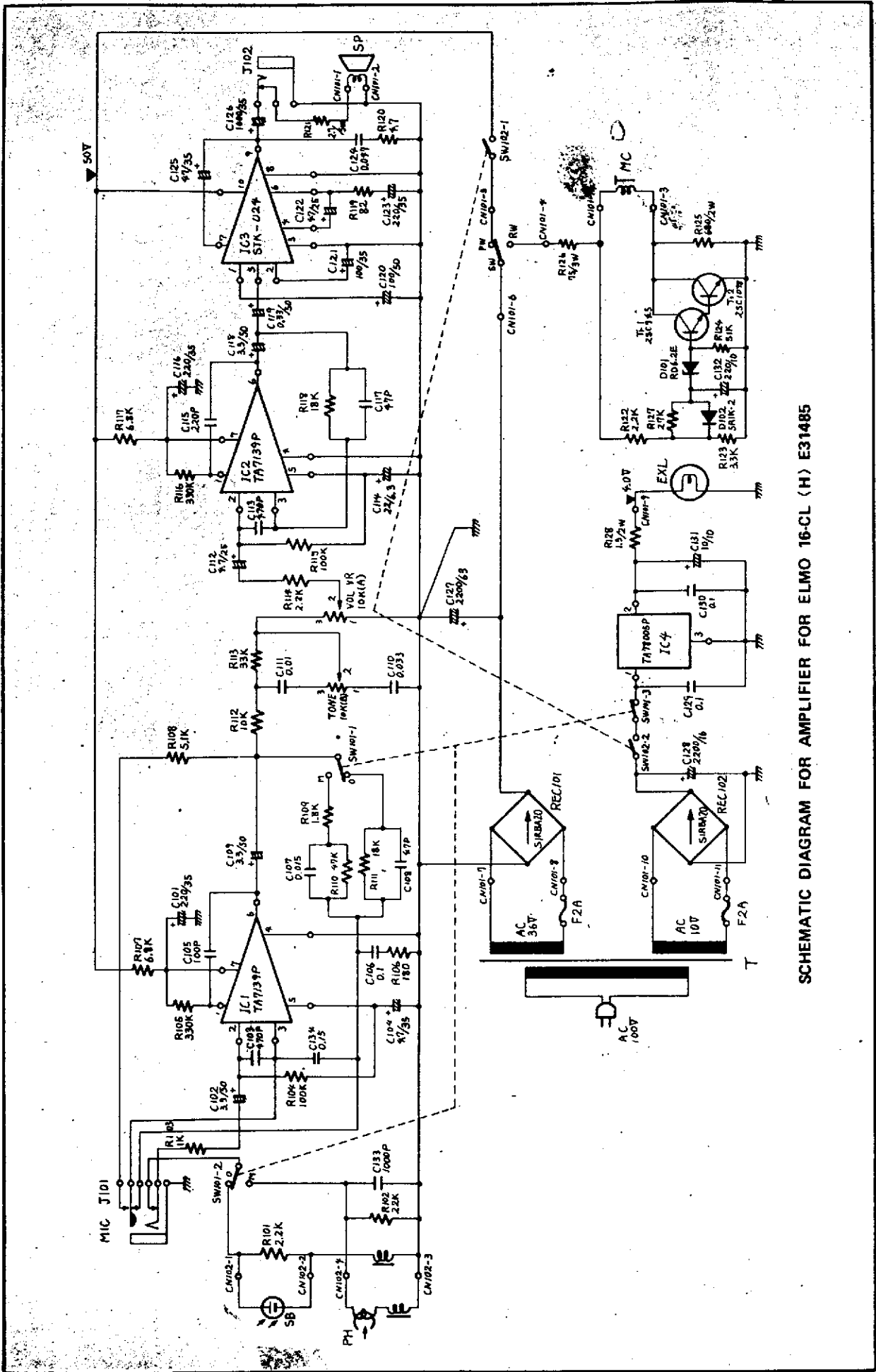

SCHEMATIC DIAGRAM FOR AMPLIFIER FOR ELMO 16-CL (H) E31485

