

*16mm*  
**CHANNEL LOADING  
SOUND PROJECTOR**

**ELMO**

**16-CL / 16-CL**  
OPTICAL

**Instruction Manual**

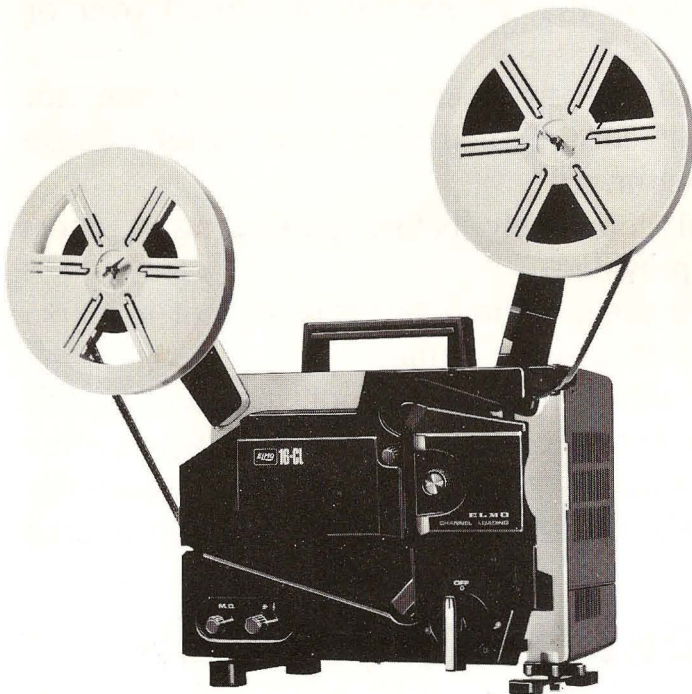

# IMPORTANT SAFEGUARDS

When using your photographic equipment, basic safety precautions should always be followed, including the following:

1. Read and understand all instructions.
2. Close supervision is necessary when any appliance is used by or near children. Do not leave appliance unattended while in use.
3. Care must be taken as burns can occur from touching hot parts.
4. Do not operate appliance with a damaged cord or if the appliance has been dropped or damaged — until it has been examined by a qualified serviceman.
5. Do not let cord hang over edge of table or counter or touch hot surfaces.
6. If an extension cord is necessary, a cord with a suitable current rating should be used. Cords rated for less amperage than the appliance may overheat. Care should be taken to arrange the cord so that it will not be tripped over or pulled.
7. Always unplug appliance from electrical outlet when not in use. Never yank cord to pull plug from outlet. Grasp plug and pull to disconnect.
8. Let appliance cool completely before putting away. Store cord in a manner provided.
9. To protect against electrical shock hazards, do not immerse this appliance in water or other liquids.
10. To avoid electric shock hazard, do not disassemble this appliance, but take it to a qualified serviceman when some service or repair work is required. Incorrect reassembly can cause electric shock hazard when the appliance is used subsequently.

**SAVE THESE INSTRUCTIONS**

Congratulations and thank you on joining the large nation-wide family of ELMO 16-CL sound projector owners.

You have selected a precision-engineered projector that will give you the quality picture and sound reproduction you expected from ELMO. However, to enjoy your ELMO projector be sure to read this entire manual for important, helpful information.

## CONTENTS

Major parts descriptions .....	2
Preparation for projection .....	4
Film threading .....	6
Projection .....	8
Various projections .....	9
When using extension speaker .....	10
Public address system .....	11
Rewinding .....	12
Maintenance .....	13
Replacing lamp and fuse .....	17
Trouble-shooting hints .....	20
Accessories .....	22
Specifications .....	25

### PLEASE NOTE

The instructions in this manual apply to Model 16-CL MO (Optical/magnetic reproduction), to Model 16-CL O (Optical reproduction only) and to Model 16-CL(H) (Optical/magnetic reproduction).

Note information as applies to specific model.

# Major parts descriptions

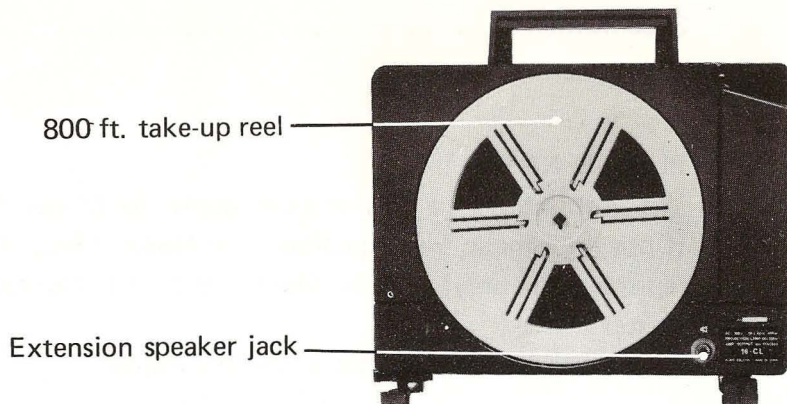
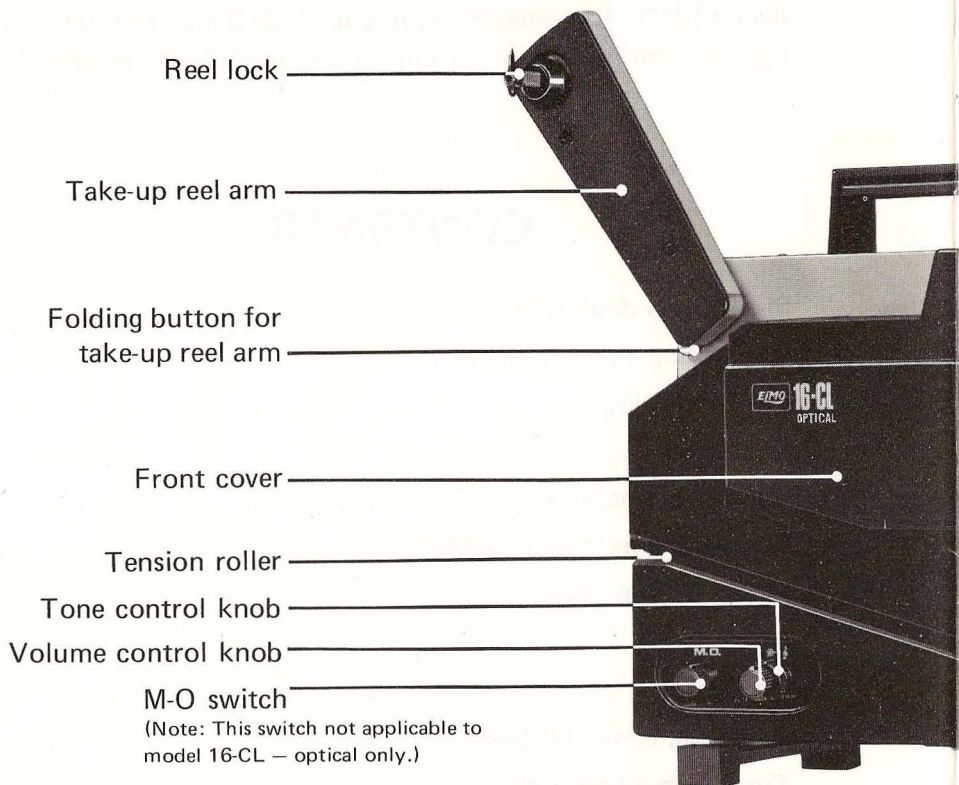

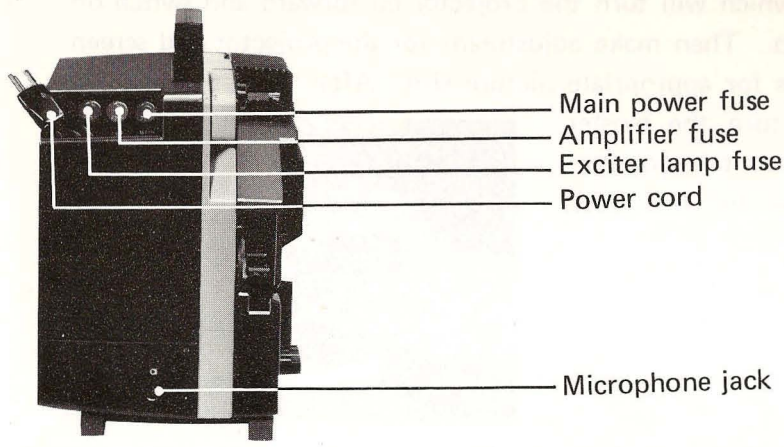
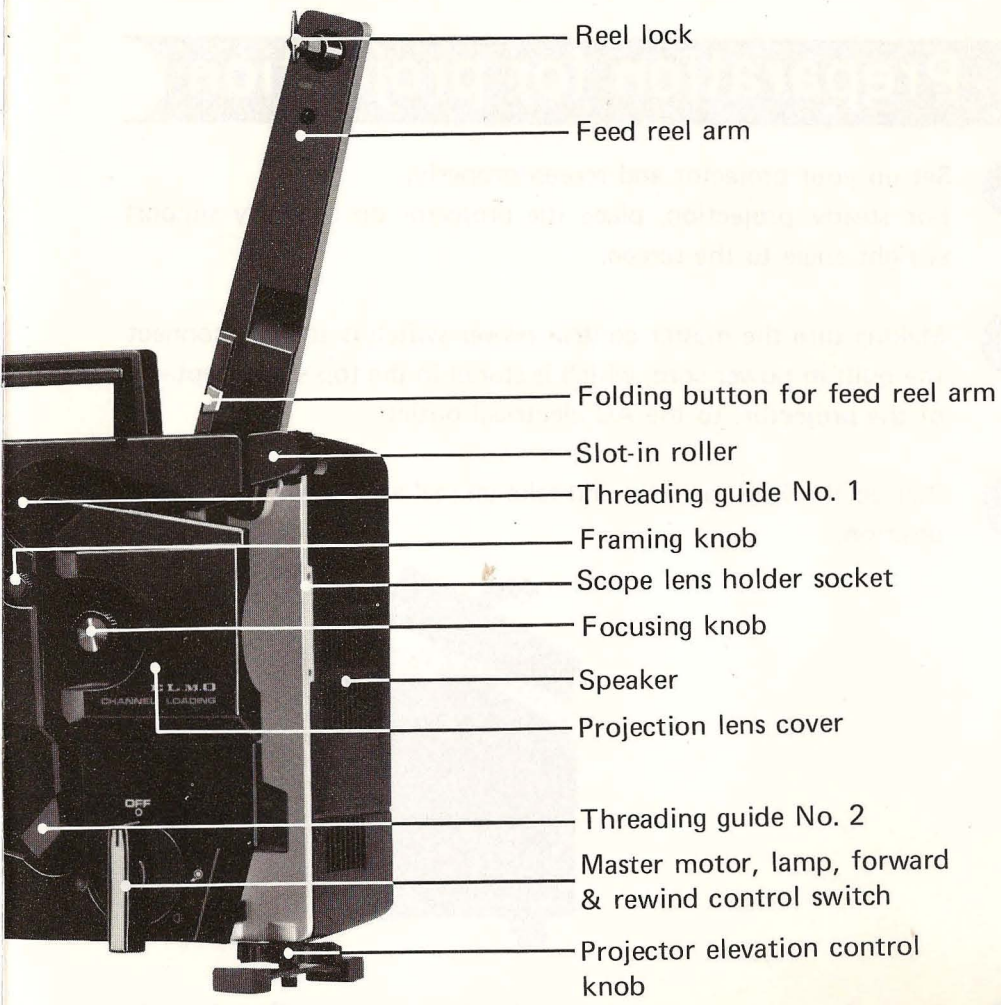

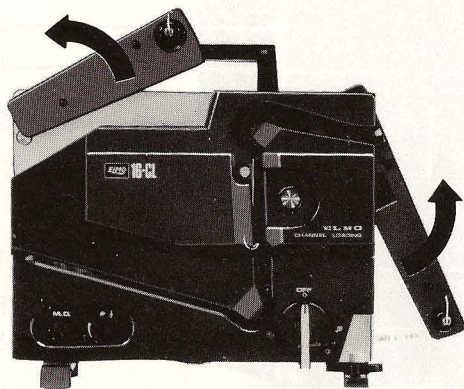

# Preparation for projection

- 1** Set up your projector and screen properly.  
For steady projection, place the projector on a sturdy support at right angle to the screen.
- 2** Making sure the master control power switch is at OFF, connect the built-in power cord, which is stored in the top side receptacle of the projector, to the AC electrical outlet.
- 3** Pull up the feed reel arm and take-up reel arm to maximum stop position.



- 4** Turn the master control switch clockwise to  through , which will turn the projector on forward and switch on the lamp. Then make adjustment for the projector and screen positions for appropriate picture size. After the set-up is completed, turn the master control switch counter-clockwise to OFF position.

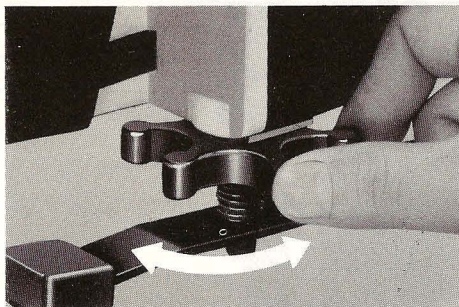

- 5** Install the take-up reel 240m (800ft.), which is stored on the rear of the projector, on the rear reel spindle. The reel capacity of the projector is max. 600m (2,000ft.). Also install the feed reel on the front reel spindle. At this time, be sure to set the reel in correct position by turning down the reel locks.

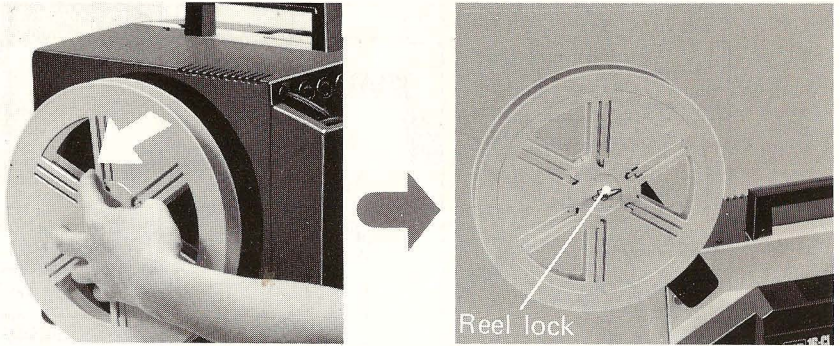

- 6** Set the M-O switch in accordance with the film to be projected. Set it to M position for magnetic sound film and O position for optical sound film, respectively.

**Note:** Not applicable to 16-CL optical model.

Optical sound film

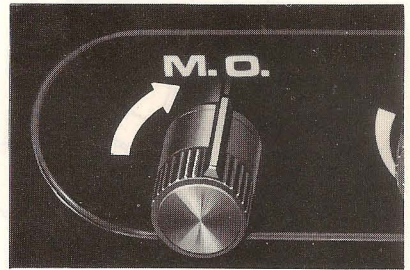
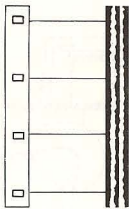

Magnetic sound film

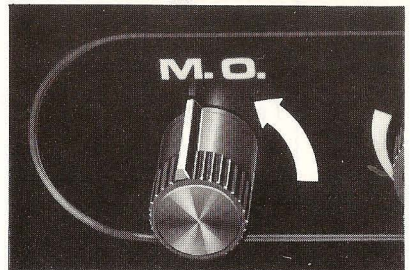
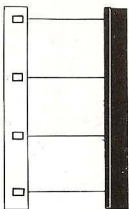

# Film threading

- 1 Hold the tip of the film leader between thumb and index finger – then pull the leader first through the slot-in roller, next over the No. 1 and No. 2 rollers and finally over the tension roller.

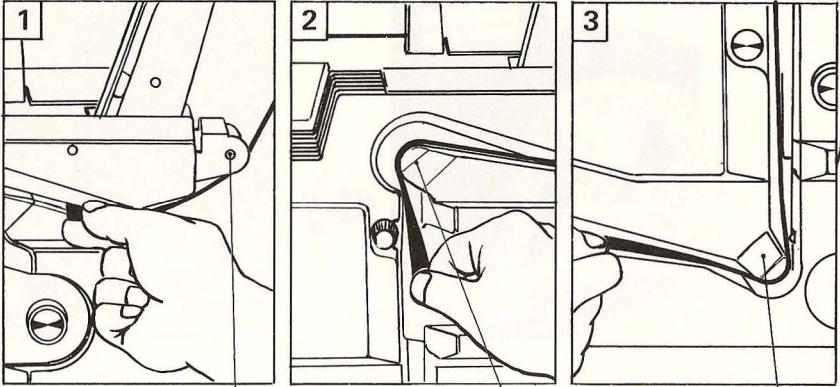

Slot-in roller    Threading guide No.1    Threading guide No.2

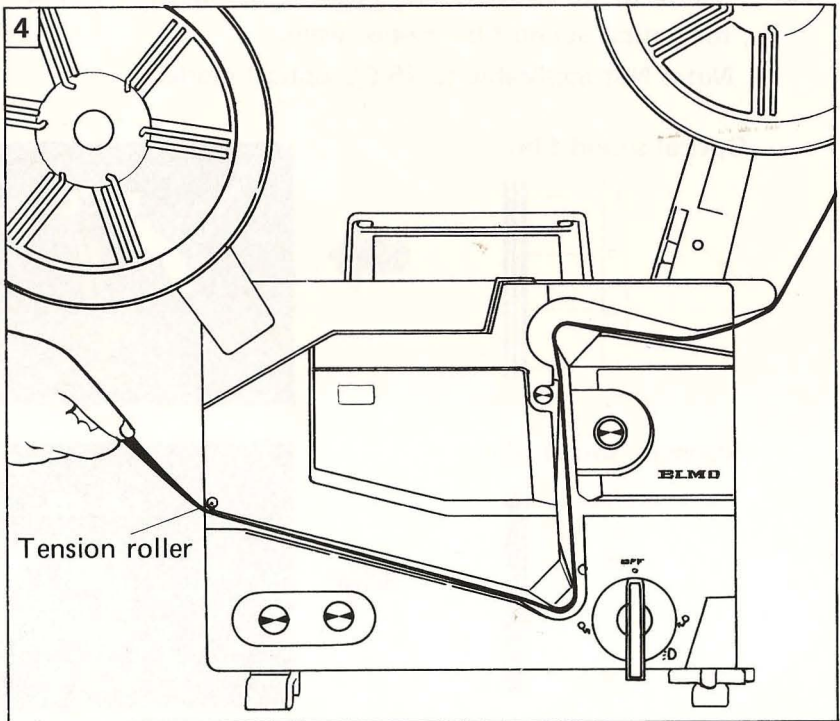

Tension roller



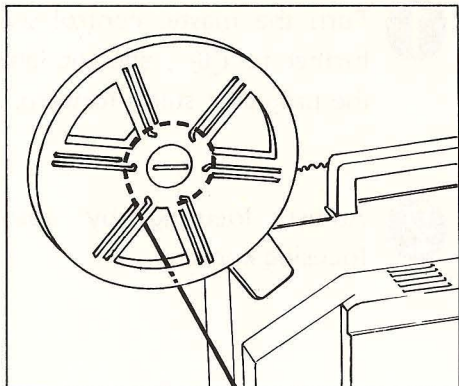

- 2** After the film threading is completed, wind the leader on the take-up reel.

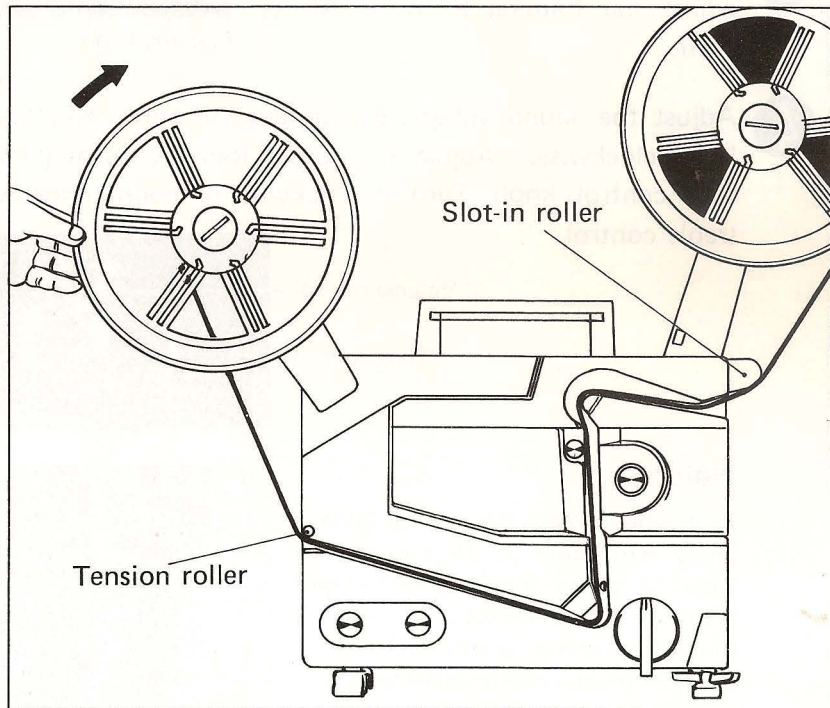

- 3** Make sure the film is properly threaded through the channel by turning the take-up reel clockwise with hand.



# Projection

1 Turn the master control switch clockwise to  , then turn it further to  , and the lamp is switched on and simultaneously the projector starts forward.

2 Adjust focusing by turning the focusing knob.

3 If a frame line appears on the screen, adjust the framing knob to left or right.

4 Adjust the sound volume by turning the outer volume control knob clockwise. Adjust the sound tone by turning the inner tone control knob: Turn it clockwise or counterclockwise for treble control.

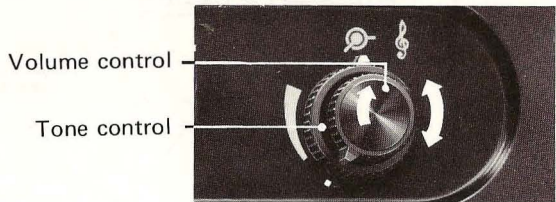
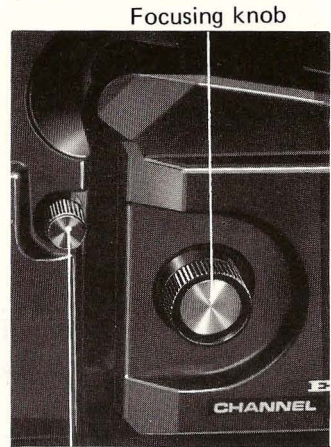



## Note:

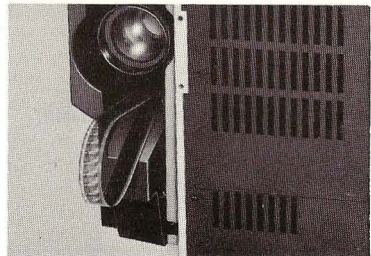

If the film breaks during projection, a safety mechanism of the projector removes the broken film from the film path automatically. In the event a film breaks, turn the projector to OFF and then remove the broken film for splicing.



# Various projections



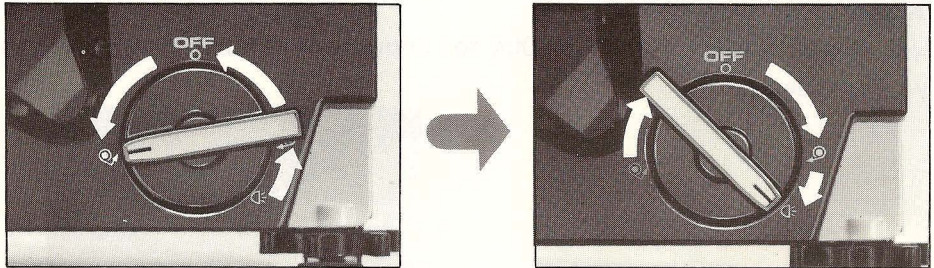

## ■ Quick review

This feature is used to see specific frames you wish to review. Turn the control switch counter clock-wise from  all the way to  and the film is quickly rewound through the gate. Then turn the control switch to OFF, as soon as you get the desired frame for re-projection.

After making sure the film has stopped, turn the control switch from OFF all the way to  through .



### Note:

- 1 When the operation switch is set to  from OFF, the projector may start rewinding only after a few seconds' pause depending on the film volume on the reel to be rewound. This is not a fault but safety mechanism for rewinding. The projector is designed to increase motor torque gradually for the protection of film.
- 2 When the operation switch is turned from  to OFF, the film may stop with some length of slackened loop. In such a case, wind up the loose portion by turning the take-up reel clockwise by hand and then turn the operation switch to .
- 3 Be sure not to turn the operation switch from OFF to  before the film is brought to a complete stop.

## ■ When using extension speaker

In the event you have occasion to use an accessory extension speaker for a large audience in a large auditorium, connect the speaker jack to the receptacle at the rear of the projector. This procedure will automatically shut off the built-in speaker circuit.

Extension speaker jack

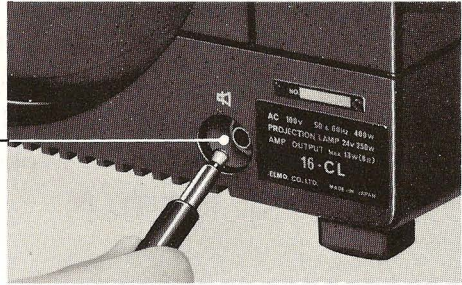

### Note:

Use optional adapter cord SC-004 for connecting Elmo extra speaker to your projector.

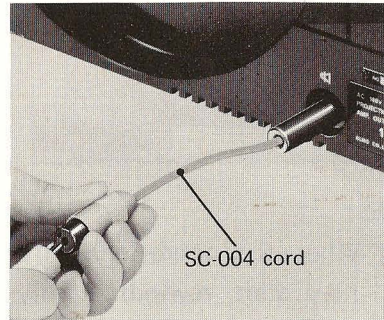

Elmo extra speaker (A)



---

## ■ Public address system

---

You can utilize your ELMO sound projector as a public address system during projection when an accessory microphone is inserted into the microphone jack at the rear left side of the projector. Use the microphone with an impedance of 500 ~ 10k. Public address through a microphone during projection supercedes the sound from the projected film.

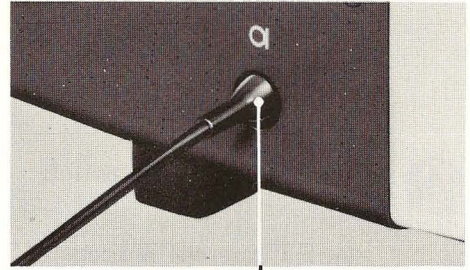
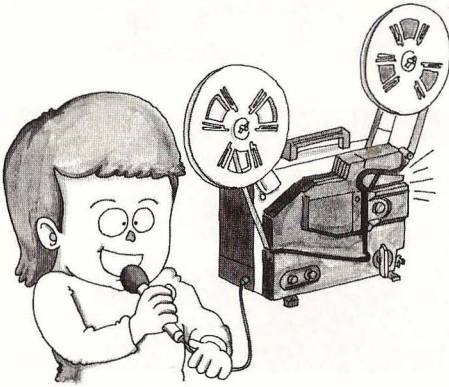

Microphone jack

---

## ■ HIGH-LOW lamp switch

---

The switch is originally set to High position.

With the switch set to Low, a little lower voltage is applied to the lamp to prolong the lamp service life. When especially bright image is required, set the switch to High to apply the rated voltage to the lamp. (Refer to How to remove and install lamp cover, page 13.)

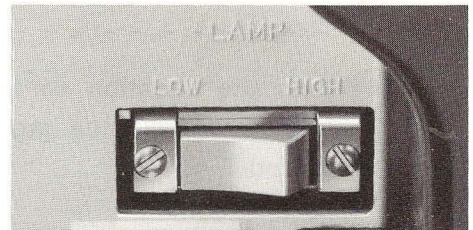

# Rewinding

- When the projection is completed, rewind the film as follows.

- 1** Insert the film end into the slot of the front reel hub.

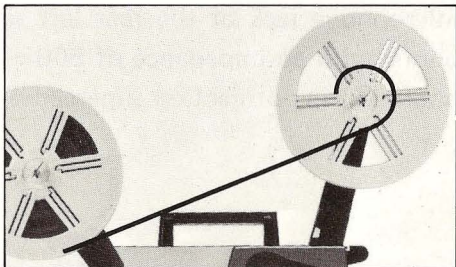

- 2** Turn the operation switch to .

In this case the projector may start rewinding only after a few seconds' pause depending on the length of film on the reel to be re-wound. The projector is designed to increase motor torque gradually for the protection of film.

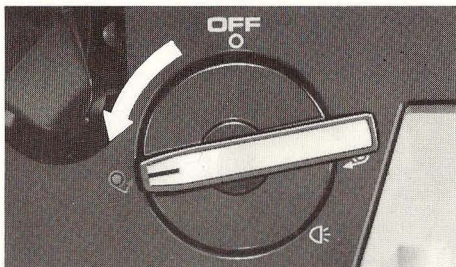

- 3** After the film is rewound, turn the operation switch to OFF.

## ■ Stowing

Disconnect the power cord first.

- 1** Fold the front and rear arms by depressing the folding buttons.
- 2** Return the power cord and take-up reel to their stowing receptacles.
- 3** Turn the elevation control knob fully counterclockwise. Never transport the projector with the elevation leg extended.

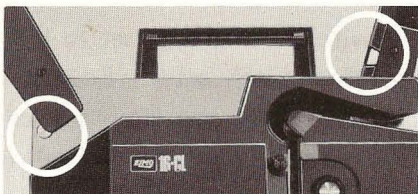

# Maintenance

Clean the film channel and lens prior to projection; accumulation of dust and film particles in the film channel gate will scratch the film and decrease the projected image quality.

## ■ How to remove and install covers

### ● Projection lens cover

To remove, hold the cover as shown in the picture and pull it out toward yourself. To install, align the guides at the lower side and push the upper part of the cover into place as shown in the picture.



Guide

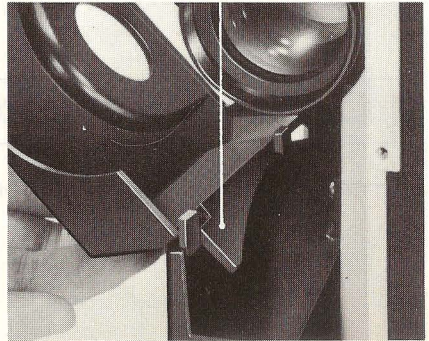

### ● Front cover

To remove, hold the cover as shown in the picture and pull it out toward yourself.

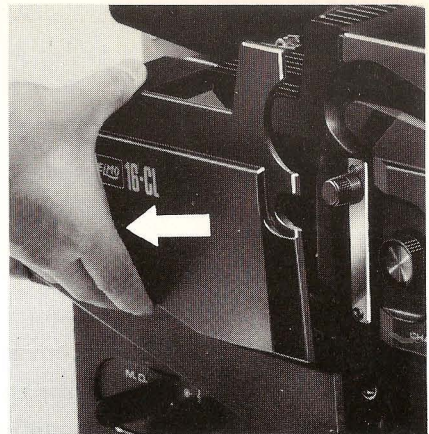

Continued on page 14

To install the cover, align the framing knob with the cover notch and the guide pins at the upper left and lower right with the corresponding holes and push the cover into position.

(Cover shown in reverse)

Cover notch

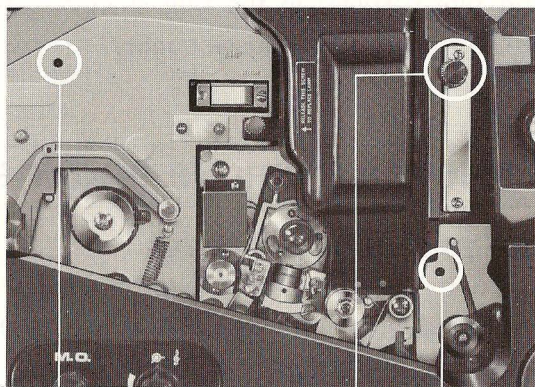
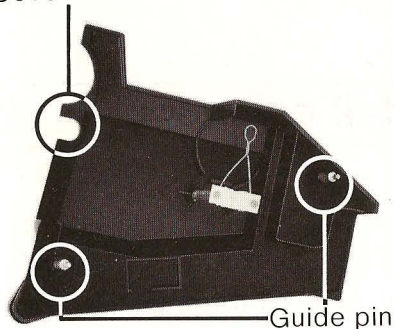

Guide pin hole

Framing knob

Guide pin hole

## ■ Cleaning film gate

Be sure to remove the film from the channel when cleaning the film gate.

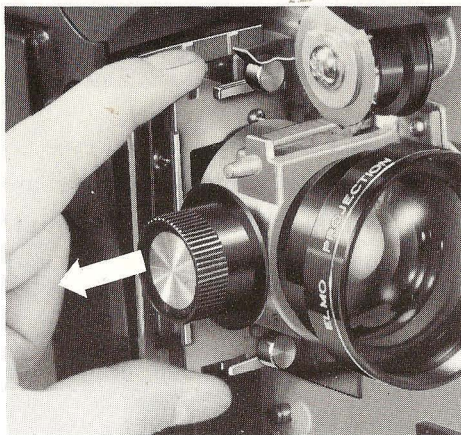

Remove the projection lens cover.

Hold the pressure plate as shown in the picture and pull it out toward yourself, and the pressure plate can be removed.



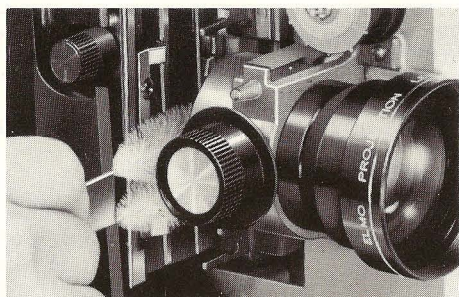
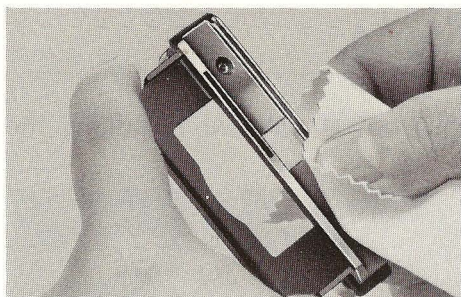

Use the stiff cleaning brush (supplied) to clean film channel gate, then wipe clean with lint-free cloth.

After the cleaning is over, align the two pins at the upper and lower parts of the pressure plate holder with the corresponding slots on the pressure plate base and push it back to place.

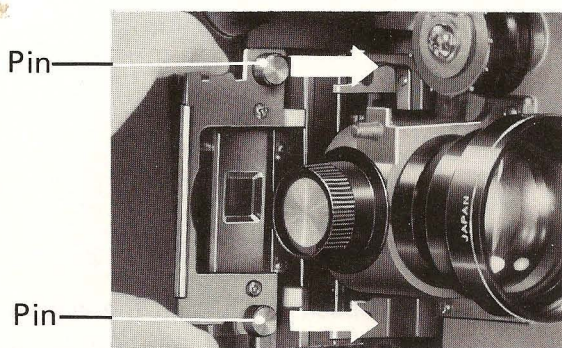

## ■ Cleaning rollers, solar battery and sound lens

Brush off the rollers, solar battery and sound lens with the clean soft brush supplied.

### Note:

If a dust adheres to sound lens or solar battery, the tone quality or volume will be decreased.

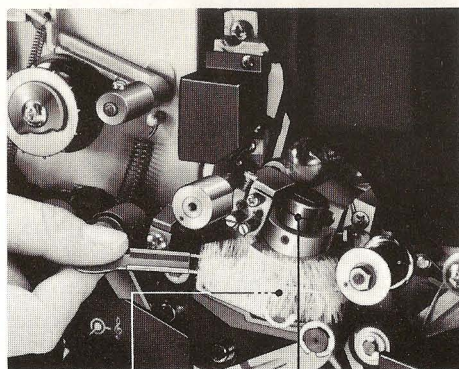

Solar battery

Sound lens

## ■ Cleaning projection lens

To remove the projection lens, pull it out straight while pulling the focusing knob toward yourself.

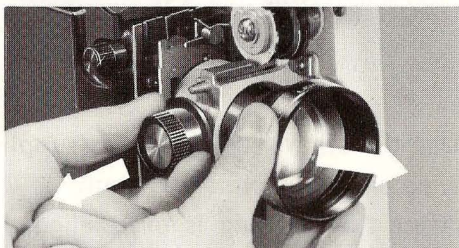

To remove the dust, wipe the lens surface gently with soft, clean, lint-free cloth.

Groove



To put the lens back, push it all the way to position while pulling the focusing knob toward yourself, and pull it until a click is heard. This click sound means that the pin at the end of the focusing knob is positively inserted into the groove of the lens holder.

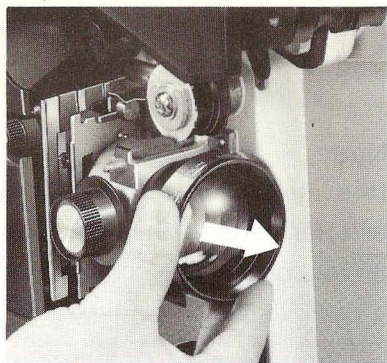
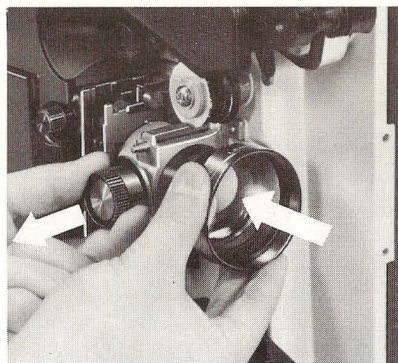

Make sure the lens can move back and forth by turning the focusing knob.

# Replacing lamp and fuse

**BE SURE TO DISCONNECT THE POWER CORD WHEN REPLACING LAMP AND FUSE.**

## ■ Replacing projection lamp

The type of projection lamp to be replaced is JCR24V-250W or ANSI ELC or Osram 64653.

- 1 Remove the front cover.
- 2 Remove the lamp cover by loosening the screws counterclockwise.

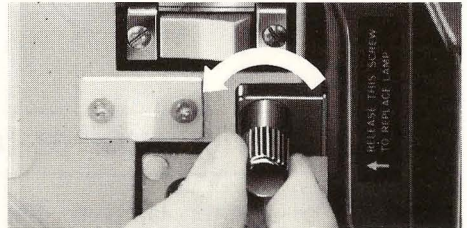

- 3 Eject the blown lamp by pushing down the ejector lever to the left.

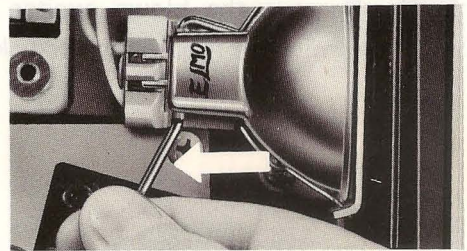

It is advisable to keep a spare projection lamp handy for immediate replacement, should an unexpected break or burn-out develop during projection.

A spare projection lamp can be stored on the back side of the front cover.

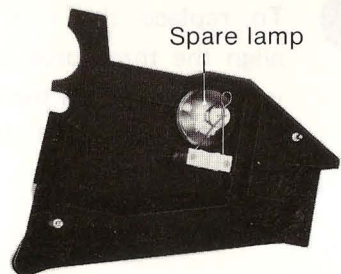

- 4** To replace a new lamp, push it into the socket as shown in the picture. At this time, be sure to insert the lamp firmly into its socket. If it is inserted halfway into the socket, the optimum projection performance can't be achieved or the socket may be burned out.

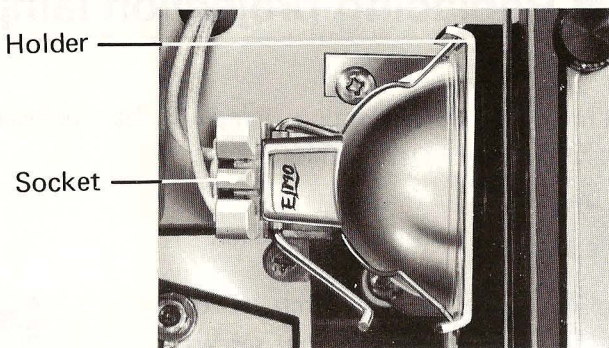

## ■ Replacing exciter lamp

The type of exciter lamp to be replaced is KE-04 or ANSI BRK.

- 1** Remove the blown exciter lamp by turning its head counterclockwise.

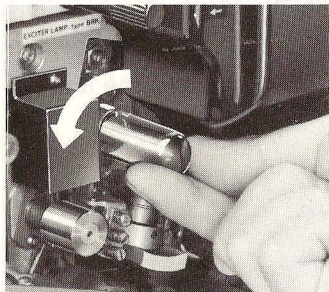

- 2** To replace the new exciter lamp, align the three prongs on the socket with the holes on the lamp flange and turn the lamp head clockwise until it locks into place.

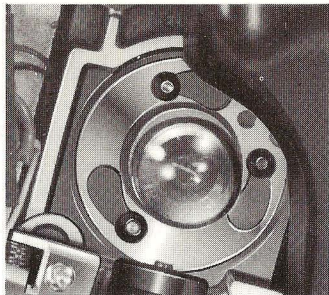

## ■ Replacing fuse

To remove the fuse holders, turn the holder heads counterclockwise with a Philips head screwdriver.

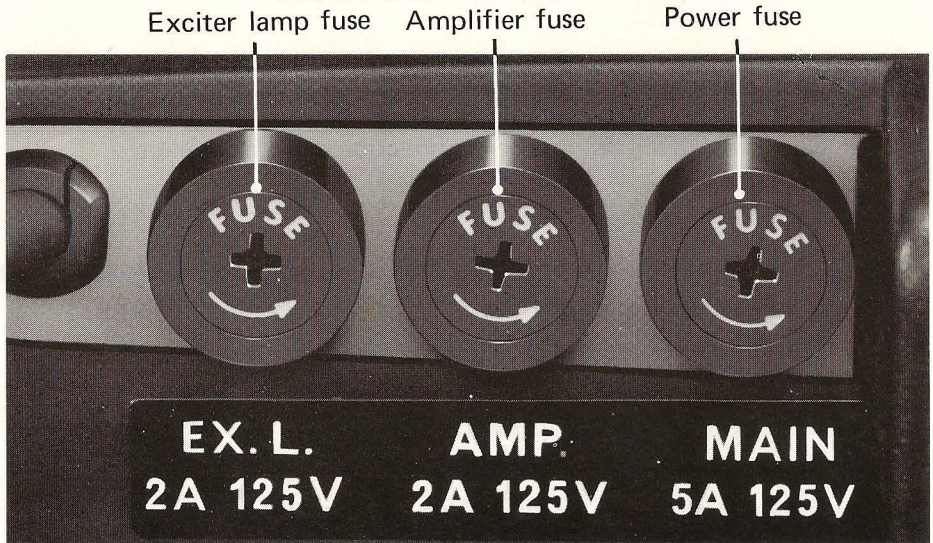

### IMPORTANT

Use the fuse with specified value for each of the three as indicated above.

- Check the exciter lamp fuse for blow-out when no sound is reproduced when projecting optical sound film. At this time, be sure also to check the exciter lamp filament for blow-out.
- Check the amplifier fuse for blow-out when no sound is reproduced when projecting either magnetic or optical film.
- When the power (main) fuse is blown out, no power is supplied to any part of the projector. Check the power (main) fuse for failure when the projector does not operate even with the power cord properly connected and the operation switch set to 

# Trouble-shooting hints

When the motor fails to operate:

- Check the power cord for proper connection.
- Check the power (main) fuse for blow-out.

When the lamp is not lit on:

- Check the lamp filament for blow-out.
- Check the lamp for proper connection with its socket.



When no sound is reproduced:

- Check the M-O switch for the correct position corresponding to the film type used. (Not applicable to 16-CL optical)
- Check the exciter lamp if lighted (only in case of optical sound film).
- Check the exciter lamp fuse for blow-out.
- Check the amplifier fuse for blow-out.
- Does a dust adhere to sound lens or solar battery?

When the image can't be properly focused:

- Check the projection lens for correct alignment, with the pin at the rear of the focusing knob, with the groove in the projection lens.

When the loop restorer operates continuously during projection:

- This may result from the damaged perforations of several frames, which make the slack length of the film between the two sprockets so short that no loop can be restored. In such a problem, turn the operation switch to OFF and turn it again all the way to  through 

## When changing the projection speed from 24 fps to 18 fps or to change electric current cycles (50Hz – 60Hz)

- The projector is originally fixed for 24 fps. operation.  
To change to 18 fps., remove the rear cover by loosening four screws and change the projection speed as shown in the picture.
- Electric current cycles are adjusted at the factory for specific destined countries. But to change electric current cycles (50Hz ~ 60Hz) remove the rear cover by loosening four screws and change the belt position as indicated.

### Note:

One belt is utilized to change electric cycles or projection film speed. When belt is used to change electric current cycles, the same belt cannot be used for change of film speed – or vice versa.

The power cord should be detached from electric outlet **WITHOUT FAIL**, before removing rear cover.

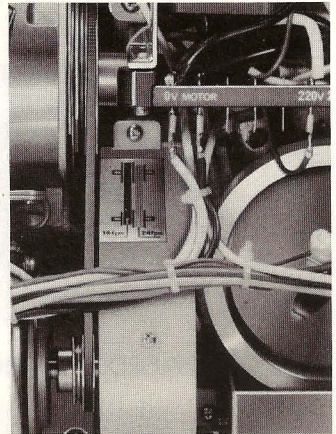

## When changing voltage

When changing voltage, the power cord should be detached from electric outlet – **WITHOUT FAIL**.

After removing rear cover, take out the connection wire and plug it into the indicated voltage terminal to be used.

There is a single voltage model projector available to comply with electrical regulations in specific countries. For this model, the above instructions are not applicable.

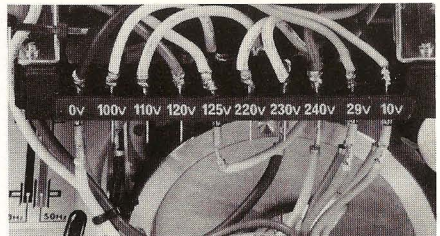

# Accessories

## ■ Scope lens

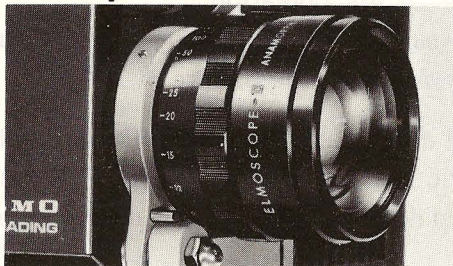

This lens is used for projecting Cinemascope movies. It can be installed in front of the projection lens simply by mounting it on the accessory socket of the projector. The projected image is horizontally magnified twice.

## ■ Zoom lens F1.7 $f = 50 \sim 100\text{mm}$



This wide range zoom lens eliminates the necessity of moving projector to or from screen for desired size of picture.

## ■ Telephoto projection lens F1.8 $f = 75\text{mm}$



This telephoto lens is for projection in a large auditorium.

## ■ Wide-angle projection lens F1.8 12.5mm



This is a unique super wide-angle lens for 16mm film projection and very effective when combined with a daylight projection device in schoolroom or display window etc.



## ■ Wide-angle projection lens F1.4 20mm



This wide-angle lens is designed for projection in a small room.

## ■ Conversion lens



This attachment lens converts the focal length of the projection lens to either x0.8 or x1.25, i.e., the standard 50mm lens plus this accessory serves as a 40mm wide-angle lens or by reversing it a 63mm telephoto lens. You can make use of it when the projected image is too small or large.

## ■ Zoom converter



When this converter is used with the projection lens, the focal length is converted continuously from x0.8 to x1.25. Using it, you can vary the size of the projected image without changing the projector-to-screen distance.

## PROJECTION DISTANCE AND IMAGE SIZE

The projection distance refers to the distance between the film plane and the screen.

		In meter.										In feet.											
												(L: Length, W: Width)											
		3	5	7	10	15	20	25	30	40	50	60	10	15	20	30	50	70	90	110	130	160	190
Standard lens (F1.2, 50mm)	L	0.4	0.7	1.0	1.4	2.1	2.9	3.6	4.3	5.8			1.4	2.1	2.9	4.3	7.2	10.1	13.0	15.8	18.7		
	W	0.6	0.9	1.3	1.9	2.9	3.8	4.8	5.8	7.7			1.9	2.9	3.8	5.8	9.6	13.5	17.4	21.2	25.1		
Standard lens with Conv. lens (x 0.8)	L	0.5	0.9	1.2	1.8	2.7	3.6	4.5	5.4				1.8	2.7	3.6	5.4	9.0	12.6	16.2	19.8			
	W	0.7	1.2	1.7	2.4	3.6	4.8	6.0	7.2				2.4	3.6	4.8	7.2	12.0	16.9	21.7	26.5			
Standard lens with Conv. lens (x 1.25)	L	0.3	0.6	0.8	1.1	1.7	2.3	2.9	3.4	4.6	5.6		1.1	1.7	2.3	3.4	5.8	8.1	10.4	12.7	15.0	18.4	
	W	0.4	0.8	1.1	1.5	2.3	3.1	3.8	4.6	6.2	7.5		1.5	2.3	3.1	4.6	7.7	10.8	13.9	17.0	20.1	24.7	
Standard lens with Elmo scope lens	L	0.4	0.7	9.9	1.4	2.1	2.9	3.6	4.3	5.8			1.4	2.1	2.9	4.3	7.2	10.0	13.0	15.8	18.7		
	W	1.1	1.9	2.7	3.8	5.8	7.7	9.6	11.5	15.4			3.8	5.8	7.7	11.5	19.3	27.0	34.7	42.4	50.1		
Telephoto lens (F1.8, 75mm)	L	0.3	0.5	0.7	0.9	1.4	1.9	2.4	2.9	3.8	4.8	5.8	0.9	1.4	1.9	2.9	4.8	6.7	8.6	10.6	12.5	15.4	18.3
	W	0.4	0.6	0.9	1.3	1.9	2.6	3.2	3.8	5.1	6.4	7.7	1.3	1.9	2.6	3.8	6.4	9.0	11.6	14.1	16.7	20.6	24.4
Wide-angle lens (F1.4, 20mm)	L	1.1	1.8	2.5	3.6	5.4							3.6	5.4	7.2	10.8	18.0						
	W	1.5	2.4	3.4	4.8	7.2							4.8	7.2	9.6	14.5	24.1						

## ■ Twin extension speakers ES-1000



High performance extension speakers with a 10" (25 cm) woofer and a tweeter. Stores conveniently in one portable case.

Rated input: 10W (Max. 15W)  
16 ohms

## ■ Carrying case with speakers



The carrying case incorporates 2 x 16.5 cm diameter dynamic speakers and is especially useful for projection in a large auditorium.

## ■ Daylight projection mirror and Translucent screen

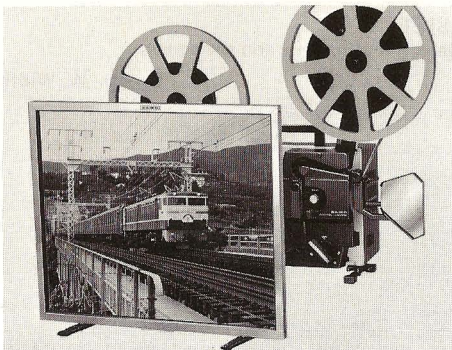

This accessory mirror provides a clear projection image in a bright area in combination with a special translucent screen. Two types of screen (80 x 60 cm, 52 x 39 cm) are available.

# Specifications

	16CL MO	16CL O
Power source	Single phase AC 50Hz and/or 60Hz	
Reel capacity	Max. 600m (2000ft) by accessory reel. 240m (800ft) standard reel with automatic take-up	
Projection speed	24fps. (18fps. is also available by model.)	
Usable film	16mm optical/ magnetic sound and silent film	16mm optical sound and silent film
Projection lens	Elmo F1.2 50mm	
Projection lamp	24V-250W halogen lamp with cold mirror (ANSI code ELC), High-Low brightness selection switch built-in.	
Motor	Induction motor	
Film loading	Elmo channel loading system	
Loop restorer	Automatic	
Rewinding	Quick-rewinding through the gate or reel-to-reel	
Reproduction	Optical/magnetic playback	Optical playback
Photoelectric element	Solar battery	
Exciter lamp	4V, 0.75A (Type KE-04, ANSI code BRK)	
Amplifier	All IC circuit	
Continuous power output (5%)	10W (8Ω)	
Music power output	15W (8Ω)	
Tone control	Adjustable	
Public address system	Available with an accessory microphone (500Ω – 10KΩ)	
Frequency response	50Hz ~ 7KHz	
Speaker	Buil-in, 12.5cm dia.	
Extension speaker	Extension speaker receptacle (8Ω) is provided.	
Dimensions	35 x 29 x 22cm (13.8 x 11.4 x 8.7 in.)	
Weight	14kg (30 lbs.)	

Specifications and designs are subject to change without prior notice.

# ***ELMO* ELMO CO.,LTD.**

6, Kamiho-dori 1-chome, Mizuho-ku,  
Nagoya, 467, JAPAN  
Tel. 052-811-5131  
Fax. 052-811-5142

## **OVERSEAS SUBSIDIARY COMPANIES**

### **U.S.A.**

#### **Elmo Mfg. Corp.**

70 New Hyde Park Road, New Hyde Park, NY 11040-9980

Tel. 516-775-3200

Fax. 516-775-3297

21720 Nordhoff Street, Chatsworth, CA 91311-5826

Tel. 818-346-4500

Fax. 818-998-4186

### **Canada**

#### **Elmo Canada Mfg. Corp.**

44 West Drive, Brampton, Ontario, L6T 3T6

Tel. 416-453-7880

Fax. 416-453-2391

### **West Germany**

#### **Elmo (Europe) G.m.b.H.**

Karl-Rudolf-Str. 178, 4000, Düsseldorf

Tel. 0211-376051-53

Fax. 0211-376630