

DRAFTING PLOTTER

SERVICE

NOTES

DPX-3300

— SPECIFICATIONS —

Maximum plotting area	X-axis: 864 mm (34") x Y-axis: 594 mm (23-5/12")	Moving speed by Position keys	15 mm/sec. (slow), 60 mm/sec. (fast)
Maximum plotting speed	450 mm/sec. (18 in./sec.) in all direction	Power consumption	100VA (120 W)
Pen up/down speed	20 times/sec.	Ambient temperature	5°C to 40°C
Resolution (hard ware)	0.0125 mm/step (0.0004 in./step)	Ambient humidity	35% to 80% (No dew forming)
Resolution (soft ware)	0.025 mm/step (0.00098 in./step)	Dimensions	W: 1170 mm x H: 852 mm x D: 175 mm (46-1/12" x 33-7/12" x 6-11/12")
Paper size	841 mm x 594 mm (ISO A1) 34" x 22" (ANSI D)	Weight	40 kg/87.2 lbs
Paper setting	Electrostatic paper hold	— INTERFACE SPECIFICATION —	
Distance accuracy	±0.2% or less of travelling distance or ±0.1 mm (whichever is larger)	PARALLEL	: Centronics
Repeatability	±0.1 mm or less with same pen ±0.25 mm or less with different pen	Input signal	: STROBE (1 bit), DATA (8 bits)
Controls	DISPLAY RESET, 8 Pen select keys, DOWN, AUTO, LL, UR, ENTER P1, P2, 4 Directional keys, FAST, PAUSE, PAPER HOLD, PEN FORCE, RESET, BAUD RATE, DIP SW-1, DIP SW-2, POWER	Output signal	: BUSY (1 bit), ACK (1 bit)
Dip switches	Font, Mode, Protocol	Signal level	: TTL level
LED indicators	X-Y coordinate display, PEN DOWN, AUTO, ERROR, POWER, PAUSE, PAPER HOLD, SERIAL/PARALLEL	Transfer system	: Asynchronous
Pens used	8 pens	SERIAL	: RS-232C
		Transfer system	: Asynchronous, Full-duplex data communication
		Baud rate	: 50, 75, 110, 134.5, 150, 200, 300, 600, 1200, 1800, 2400, 3600, 4800, 7200, 9600
		Stop bit	: 1 or 2 bits
		Parity check	: Odd, Even, None
		Data bit	: 7 or 8 bits
		Connector	: DB-25S

— TOP VIEW —



— SIDE VIEW —

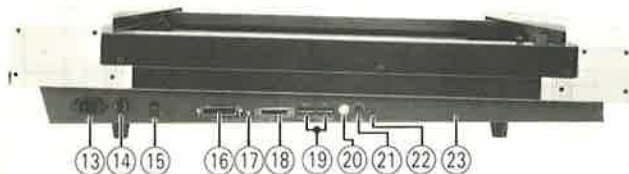

— PANEL VIEW —

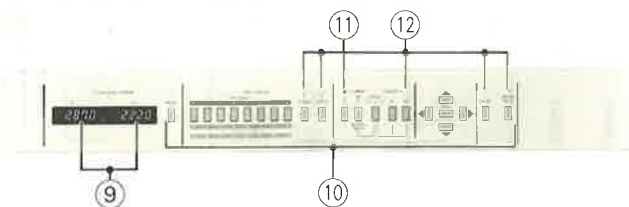

①	22025316	Motor cover
②	12479187	Button (Black)
③	7582721000	Pen stock Ass'y
④	22215517	Front panel
⑤	22345303	Panel protector
⑥	22355364	Drawing table
	22025760	Electrostatic board
⑦	22025317	Y-rail cover
⑧	22215518	Rear panel
⑨	15029184	LED GL3D507B
⑩	22485116	Button
	13129715	Switch SKHCAA110A
⑪	15029201	LED GL-3HY1 (Yellow)
⑫	15029110	LED GL-3AR1 (Red)
⑬	13429708	AC Inlet
⑭	12199515	Fuse holder for 100V, 220V, 240V
	12199551	Fuse holder for 117V
	12559106	SGA-2A for 100V
	12559302	MGC2A for 117V
	12559513	CEE-1AT for 220V, 240V
⑮	13149116	Power switch
⑯	13429189	36 pin Parallel connector
⑰	15029200	LED SPR-54MVW (Red & Green)
⑱	13429190	25 pin Serial connector
⑲	13169662	Dip SW DYS-8
⑳	13169658	DIGITAL switch
㉑	13279817	Potentiometer (1 Kohm)
㉒	13169665	Tact switch (Reset)
㉓	22815559	Chassis

— BLOCK DIAGRAM —

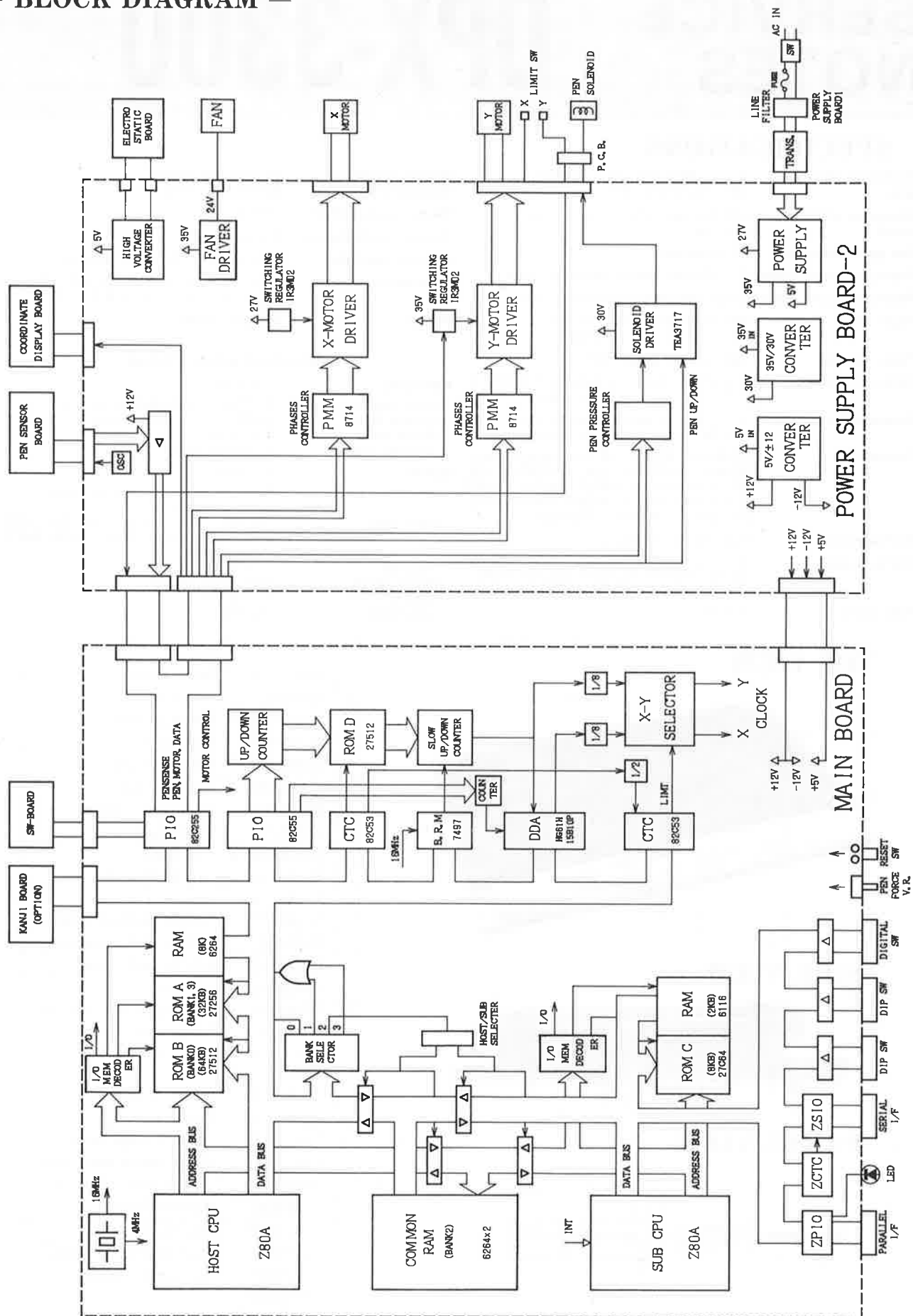

— IC DATA —

TC4584BP
HEX SCHMITT TRIGGER

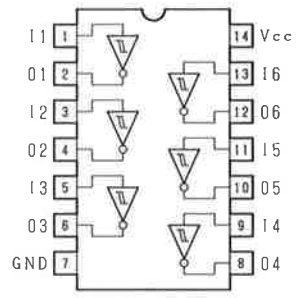

TL497ACN

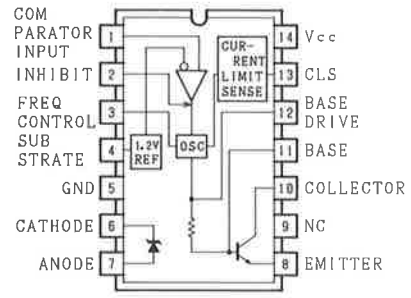

HD75188P

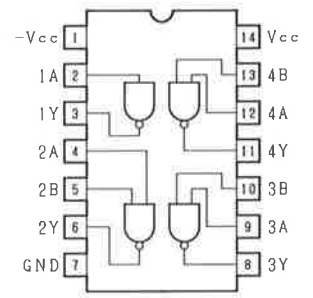

IR2C07
7-Segment
LED Display Driver

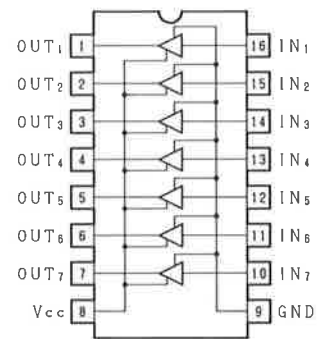

TC4077BP
QUAD EXCLUSIVE-NOR GATE

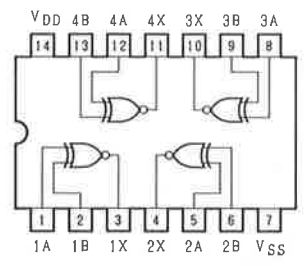

TC4001BF
QUAD 2-INPUT
POSITIVE NOR GATE

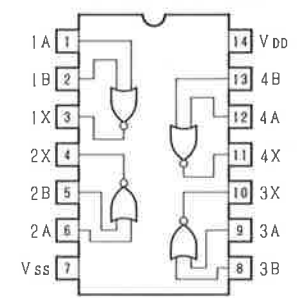

Logic : $X = A + B$

HD75189P

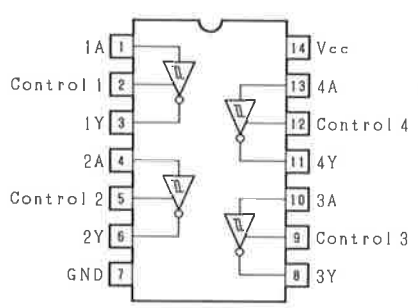

M74LS20P
Dual 4-input
Positive NAND Gates

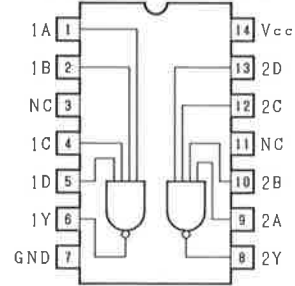

Logic : $Y = A \cdot B \cdot C \cdot D$

TC74HC08P
QUAD 2-INPUT AND GATE

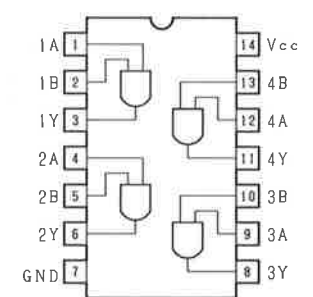

Logic : $Y = A \cdot B$

IR2C30
7-Unit 100mA
Transistor Array

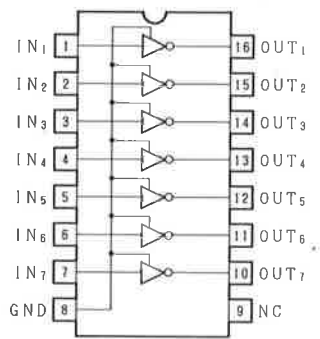

TC74HC51P
DUAL 2-WIDE 3-INPUT, 2-WIDE
2-INPUT AND-OR-INVERT GATES

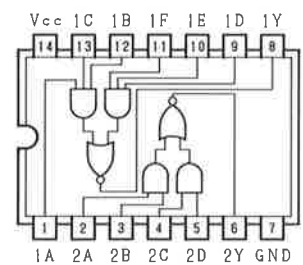

Logic :
 $1Y = (1A \cdot 1B \cdot 1C) + (1D \cdot 1E \cdot 1F)$
 $2Y = (2A \cdot 2B) + (2C \cdot 2D)$

TC74HC32P
QUAD 2-INPUT OR GATE

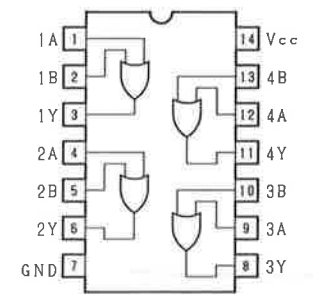

Logic : $Y = A + B$

— IC DATA —

TC74HC10P
TRIPLE 3-INPUT NAND GATE

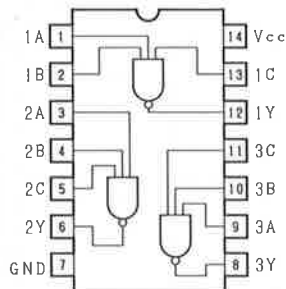

Logic : $Y = \overline{A \cdot B \cdot C}$

TC4069UBP
HEX INVERTER

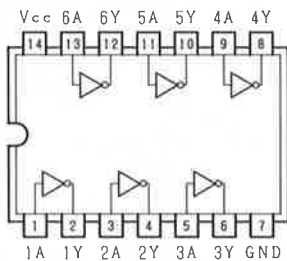

Logic : $Y = \overline{A}$

TC74HC125P
QUAD BUS BUFFER GATES
WITH 3-STATE OUTPUTS

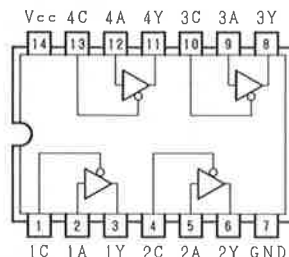

Logic : $Y = A$

SN74LS541N
NON INVERTED 3 STATE OUTPUTS

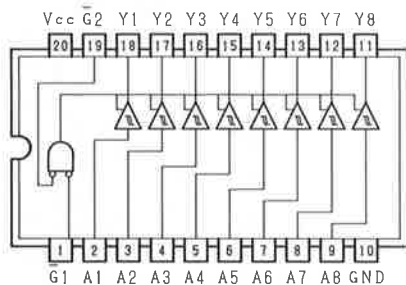

Logic : $Y = A$

HD7414P
HEX SCHMITT TRIGGER

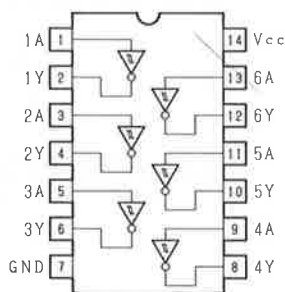

Logic : $Y = \overline{A}$

TC74HC04P
HEX INVERTER

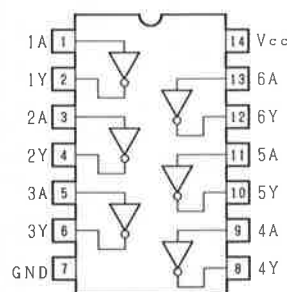

TC74HC04P
HEX INVERTER

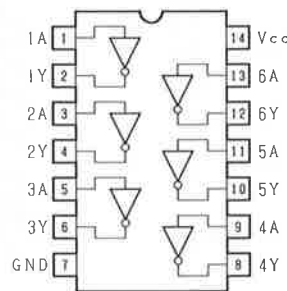

Logic : $Y = \overline{A}$

M74LS30P

8-input
Positive NAND Gate

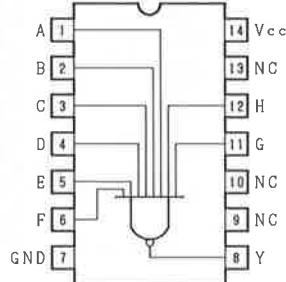

Logic : $Y = \overline{A \cdot B \cdot C \cdot D \cdot E \cdot F \cdot G \cdot H}$

1R3M02
Switching Regulator Control Circuit

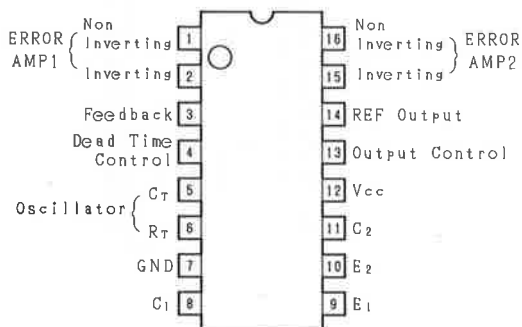

TC74HC04P
HEX INVERTER

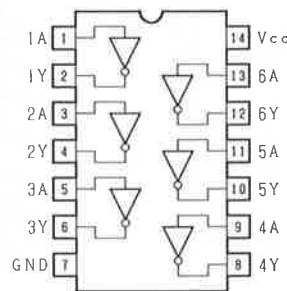

Logic : $Y = \overline{A}$

TC74HC02P
HD74LS02P
QUAD 2-INPUT NOR GATE

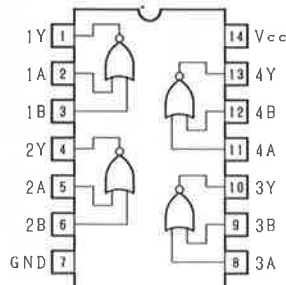

Logic : $Y = \overline{A+B}$

HD7406P
HEX INVERTER BUFFER/DRIVER
WITH OPEN COLLECTOR
HIGH VOLTAGE OUTPUT

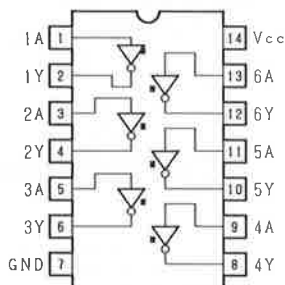

※: OPEN Collector
Logic : $Y = \overline{A}$

TC74HC00P
QUAD 2-INPUT NAND GATE

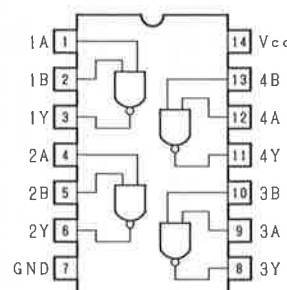

Logic : $Y = \overline{A \cdot B}$

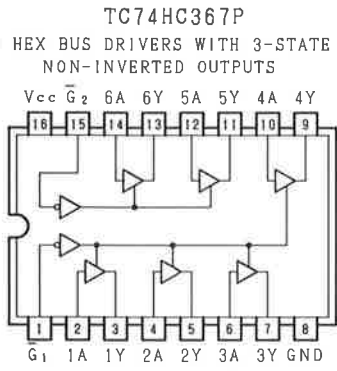

Logic: Y=A

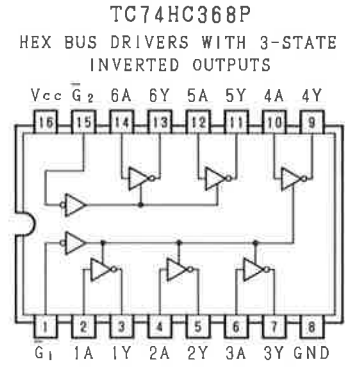

Logic: Y=A̅

SN7497
SYNCHRONOUS 6-BIT
BINARY RATE MULTIPLERS

Pin Configuration

Truth Table

STATE AND/OR RATE FUNCTION TABLE (See Note A)

CLEAR	ENABLE	STROBE	INPUTS						NUMBER OF CLOCK PULSES	UNITY/ CASCADE	OUTPUTS			NOTES	
			F	E	D	C	B	A			Y	Z	ENABLE		B
H	X	H	X	X	X	X	X	X	X	H	L	H	H	H	B
L	L	L	L	L	L	L	L	L	64	H	L	H	1	1	C
L	L	L	L	L	L	L	L	H	64	H	1	1	1	1	C
L	L	L	L	L	L	L	H	L	64	H	2	2	1	1	C
L	L	L	L	L	L	H	L	L	64	H	4	4	1	1	C
L	L	L	L	L	H	L	L	L	64	H	8	8	1	1	C
L	L	L	L	H	L	L	L	L	64	H	16	16	1	1	C
L	L	L	L	H	L	L	L	L	64	H	32	32	1	1	C
L	L	L	H	H	H	H	H	H	64	H	63	63	1	1	C
L	L	L	H	H	H	H	H	H	64	L	H	63	1	1	D
L	L	L	H	L	H	L	L	L	64	H	40	40	1	1	E

NOTE: A. H=high level, L=low level, X=irrelevant. All remaining entries are numeric counts.
 B. This is a simplified illustration of the clear function. The states of clock and strobe can affect the logic level of Y and Z. A low unity/cascade will cause output Y to remain high.
 C. Each rate illustrated assumes a constant value at rate inputs, however, these illustrations in no way prohibit variable rate inputs.
 D. Unity/cascade is used to inhibit output Y.
 E. $f_{out} = \frac{M \cdot f_{in}}{64} = \frac{(8+32) \cdot f_{in}}{64} = \frac{40 \cdot f_{in}}{64} = 0.625 f_{in}$

TC4528BF
DUAL MONOSTABLE MULTIVIBRATOR

Pin Configuration

Truth Table

INPUT	OUTPUT	NOTE
A B CD	Q Q̅	
F H H H	[Pulse]	OUTPUT PULSE
F L H L	H H	INHIBIT
H F H L	H H	INHIBIT
L F H L	[Pulse]	OUTPUT PULSE
* * L L	H H	INHIBIT

* Don't Care

TC74HC393P
DUAL 4-BIT BINARY COUNTERS

Pin Configuration

Truth Table

COUNT SEQUENCE (EACH COUNTER)

COUNT	OUTPUT			
	QD	QC	QB	QA
0	L	L	L	L
1	L	L	L	H
2	L	L	H	L
3	L	L	H	H
4	L	H	L	L
5	L	H	L	H
6	L	H	H	L
7	L	H	H	H
8	H	L	L	L
9	H	L	L	H
10	H	L	H	L
11	H	L	H	H
12	H	H	L	L
13	H	H	L	H
14	H	H	H	L
15	H	H	H	H

Positive logic: High input to clear resets all four outputs low

— IC DATA —

TC4024BF
7-STAGE BINARY COUNTER

Pin Configuration

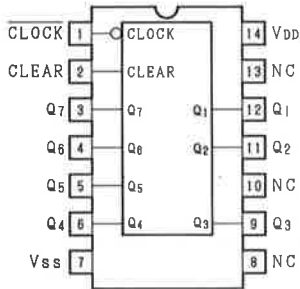

Truth Table

CLOCK	CLEAR	OUTPUT STATE
*	H	All Outputs = "L"
	L	No Change
	L	Advance to Next State

* Don't Care

TC74HC245P
OCTAL BUS TRANCEIVER
3-STATE, NON-INVERTING

Pin Configuration

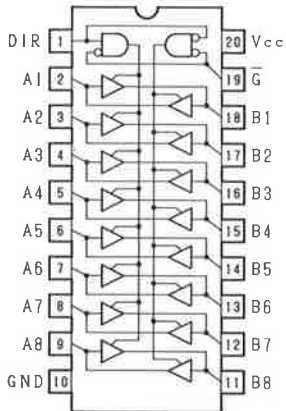

Truth Table

INPUTS		FUNCTION		OUTPUTS
\bar{G}	DIR	A BUS	B BUS	HC245
L	L	OUTPUT	INPUT	A = B
L	H	INPUT	OUTPUT	B = A
H	*	High impedance		Z

*:Don't care

Z:High impedance

TC4516
BINARY UP/DOWN COUNTER

Pin Configuration

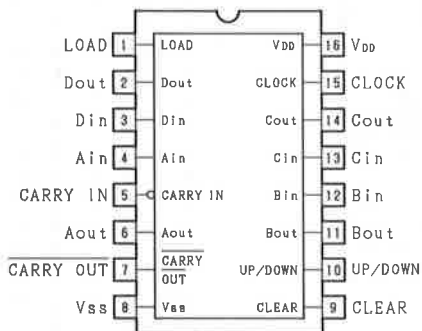

Truth Table

CARRY IN	UP/DOWN	LOAD	CLEAR	FUNCTION
H	*	L	L	NO COUNT
L	H	L	L	UP COUNT
L	L	L	L	DOWN COUNT
*	*	H	L	PRESET
*	*	*	H	CLEAR

* Don't Care

TC74HC138P
3-TO-8 LINE DECODER

Pin Configuration

Truth Table

INPUTS						OUTPUTS							SELECTED OUTPUT	
ENABLE			SELECT			$\bar{Y}0$	$\bar{Y}1$	$\bar{Y}2$	$\bar{Y}3$	$\bar{Y}4$	$\bar{Y}5$	$\bar{Y}6$		$\bar{Y}7$
G1	G2A	G2B	C	B	A									
L	*	*	*	*	*	H	H	H	H	H	H	H	H	NONE
*	H	*	*	*	*	H	H	H	H	H	H	H	H	NONE
*	*	H	*	*	*	H	H	H	H	H	H	H	H	NONE
H	L	L	L	L	L	L	H	H	H	H	H	H	H	$\bar{Y}0$
H	L	L	L	L	H	H	L	H	H	H	H	H	H	$\bar{Y}1$
H	L	L	L	H	L	H	H	L	H	H	H	H	H	$\bar{Y}2$
H	L	L	L	H	H	H	H	H	L	H	H	H	H	$\bar{Y}3$
H	L	L	H	L	L	H	H	H	H	L	H	H	H	$\bar{Y}4$
H	L	L	H	L	H	H	H	H	H	H	L	H	H	$\bar{Y}5$
H	L	L	H	H	L	H	H	H	H	H	H	L	H	$\bar{Y}6$
H	L	L	H	H	H	H	H	H	H	H	H	L	H	$\bar{Y}7$

* Don't Care

TC74HC374P
OCTAL D-TYPE FLIP FLOP
WITH 3-STATE OUTPUT
NON-INVERTING

Pin Configuration

Truth Table

INPUTS			OUTPUT
\bar{OE}	CK	D	Q
H	X	X	Z
L		X	Qn
L		L	L
L		H	H

X : Don't care
Z : High impedance
Qn: No Change

TC74HC74P
DUAL D FLIP FLOP
WITH PRESET AND CLEAR

Pin Configuration

Truth Table

INPUTS				OUTPUTS		FUNCTION
CLR	PR	D	CK	q	\bar{q}	
L	H	*	*	L	H	CLEAR
H	L	*	*	H	L	PRESET
L	L	*	*	H	H	—
H	H	L		L	H	—
H	H	H		H	L	—
H	H	*		Qn	$\bar{Q}n$	NO CHANGE

* Don't Care

— IC DATA —

TC74HC139P
DUAL 2-TO-4 LINE DECODER

Pin Configuration

Truth Table

ENABLE	SELECT		OUTPUTS				SELECTED OUTPUT
	\bar{G}	B	A	$\bar{Y0}$	$\bar{Y1}$	$\bar{Y2}$	
H	*	*	H	H	H	H	NONE
L	L	L	L	H	H	H	$\bar{Y0}$
L	L	H	H	L	H	H	$\bar{Y1}$
L	H	L	H	H	L	H	$\bar{Y2}$
L	H	H	H	H	H	L	$\bar{Y3}$

* Don't Care

TC74HC163P•M74LS163AP
SYNCHRONOUS PRESETTABLE
4-BIT BINARY COUNTER

Pin Configuration

Truth Table

INPUTS					OUTPUTS				FUNCTION
CLR	LD	PE	TE	CK	QA	QB	QC	QD	
L	*	*	*	\bar{f}	L	L	L	L	REST TO "0"
H	L	*	*	\bar{f}	A	B	C	D	PRESET DATA
H	H	*	L	\bar{f}	NO CHANGE				NO COUNT
H	H	L	*	\bar{f}	NO CHANGE				NO COUNT
H	H	H	H	\bar{f}	COUNT UP				COUNT
*	*	*	*	\bar{f}	NO CHANGE				NO COUNT

Note * : Don't Care
A, B, C, D: Logic Level of Data Inputs
Carry : CARRY = TE•QA•QB•QC•QD

TC74HC174P
HEX D-TYPE
FLIP FLOP WITH CLEAR

Pin Configuration

Truth Table

INPUTS			OUTPUT	FUNCTION
CLEAR	D	CLOCK	Q	
L	*	*	L	Clear
H	L	\bar{f}	L	—
H	H	\bar{f}	H	—
H	*	\bar{f}	Qn	No change

* : Don't Care

TC74HC175P
QUAD D-TYPE
FLIP FLOP WITH CLEAR

Pin Configuration

Truth Table

INPUTS			OUTPUTS		FUNCTION
CLEAR	D	CLOCK	q	\bar{q}	
L	X	X	L	H	CLEAR
H	L	\bar{f}	L	H	—
H	H	\bar{f}	H	L	—
H	X	\bar{f}	Qn	\bar{Qn}	NO CHANGE

X : Don't Care

TC40H244P
NONINVERTED
3-STATE OUTPUTS

Pin Configuration

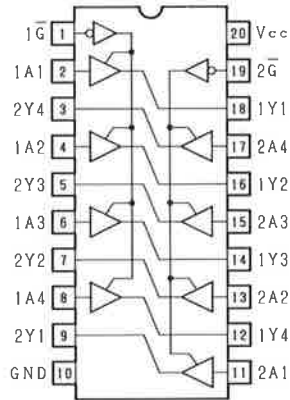

Truth Table

INPUTS		OUTPUTS
G	A _n	Y _n
L	L	L
L	H	H
H	*	Z

* : Don't Care
Z : High Impedance

TC74HC240P
INVERTED 3-STATE OUTPUTS

Pin Configuration

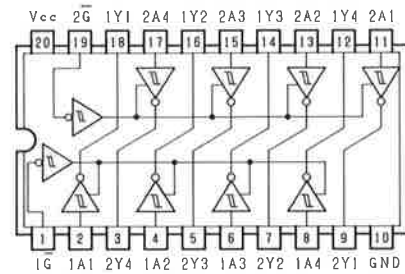

Truth Table

INPUTS		OUTPUTS
G	A _n	Y _n
L	L	H
L	H	L
H	*	Z

* : Don't Care
Z : High Impedance

TC74HC123P
RETRIGGERABLE
MONOSTABLE MULTIVIBRATORS

Pin Configuration

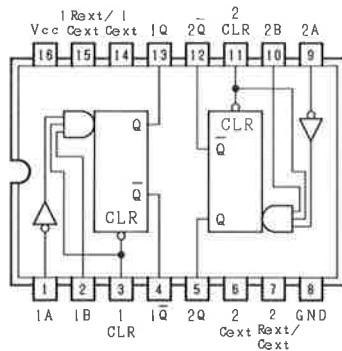

Truth Table

INPUTS		OUTPUTS	
CLEAR	A B	Q	Q
L	X X	L	H
X	H X	L	H
X	X L	L	H
H	L ↑	□	□
H	↓ H	□	□
↑	L H	□	□

X : Don't Care

M74LS156P
DUAL 2-LINE-TO-4-LINE
DECODERS/DEMULTIPLEXERS

Pin Configuration

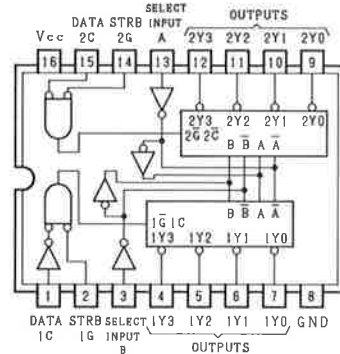

Truth Table

3-LINE-TO-8-LINE DECODER
OR 1-LINE-TO-8-LINE DEMULTIPLEXER

INPUTS			OUTPUTS								
SELECT	STROBE OR DATA		(0)	(1)	(2)	(3)	(4)	(5)	(6)	(7)	
C ¹	B	A	G ¹	2Y0	2Y1	2Y2	2Y3	1Y0	1Y1	1Y2	1Y3
X	X	X	H	H	H	H	H	H	H	H	H
L	L	L	L	L	H	H	H	H	H	H	H
L	L	H	L	H	L	H	H	H	H	H	H
L	H	L	L	H	H	L	H	H	H	H	H
L	H	H	L	H	H	H	L	H	H	H	H
H	L	L	L	H	H	H	H	L	H	H	H
H	L	H	L	H	H	H	H	H	L	H	H
H	H	L	L	H	H	H	H	H	H	L	H
H	H	H	L	H	H	H	H	H	H	H	L

1C = inputs 1C and 2C connected together
1G = inputs 1G and 2G connected together
H = high level, L = low level, X = irrelevant

— IC DATA —

MBM27C512-25

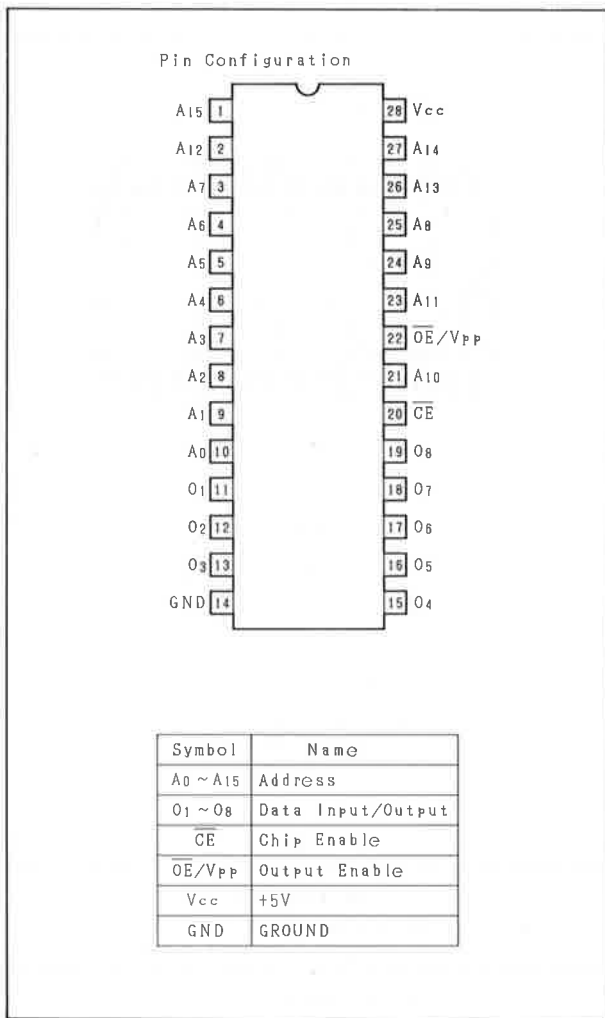

MBM27C64

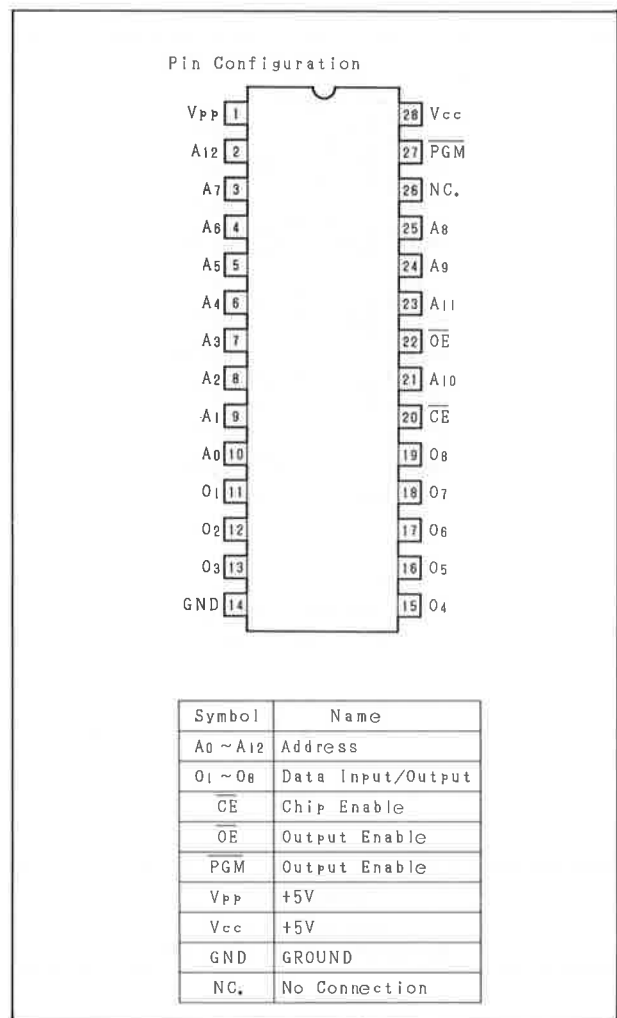

MBM27C256

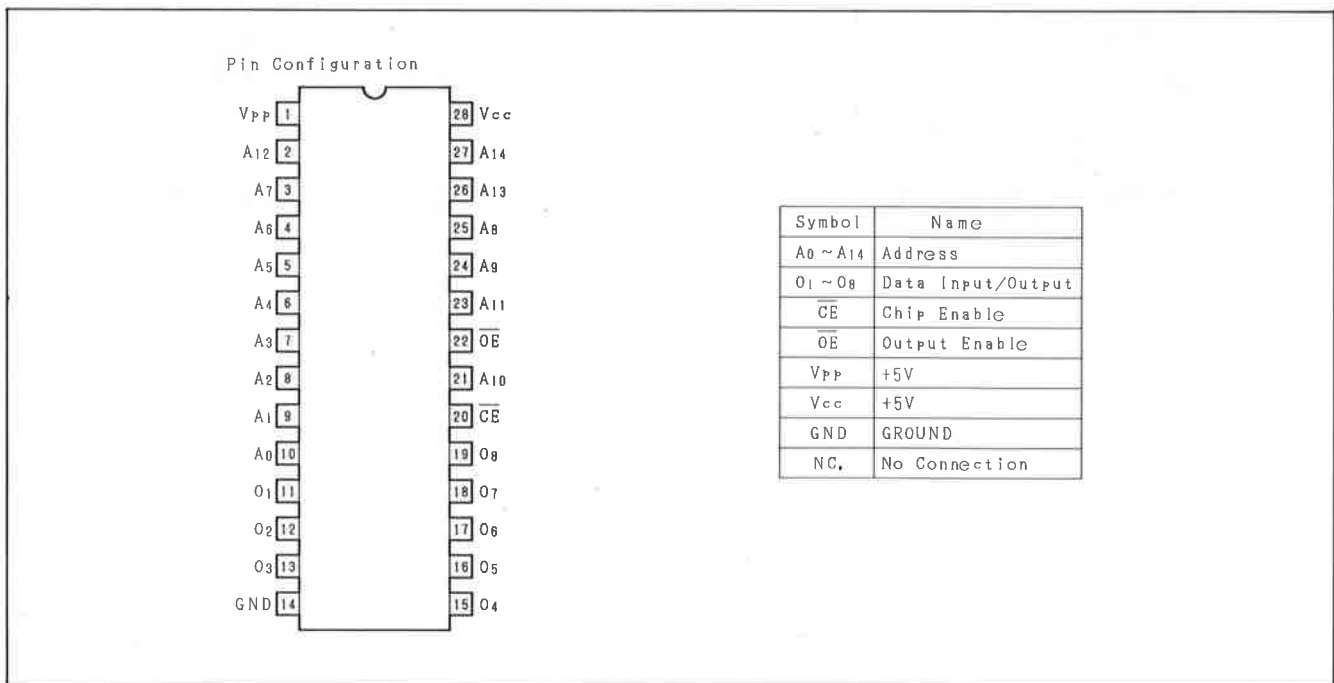

HM6264ASP-15
8192-word X 8bit
High Speed Static RAM

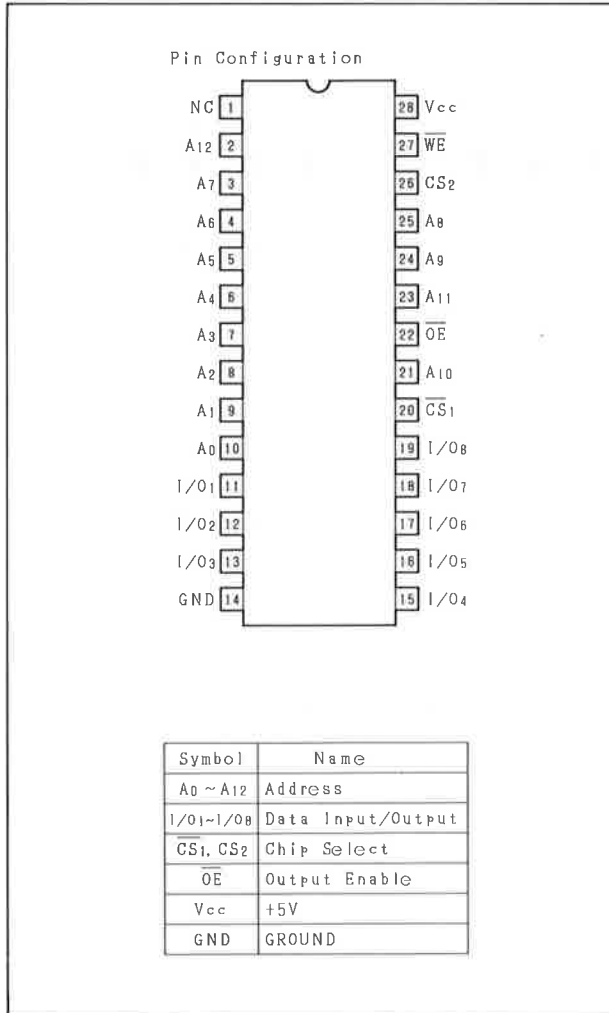

HM6116P-4
2048-word X 8bit
High Speed Static RAM

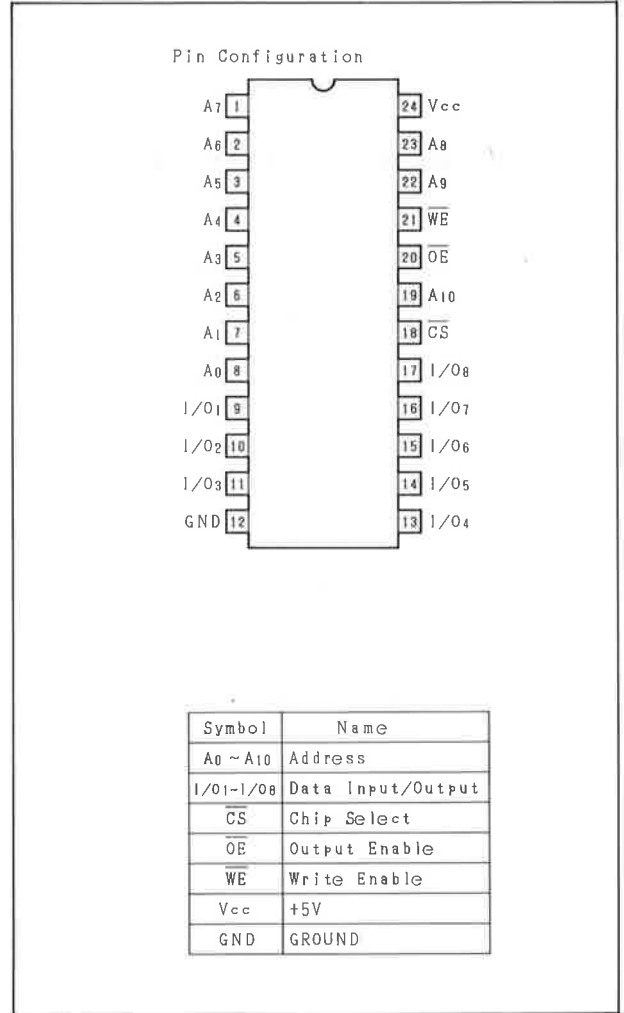

PMM8714
Universal Controller
for 5-phase

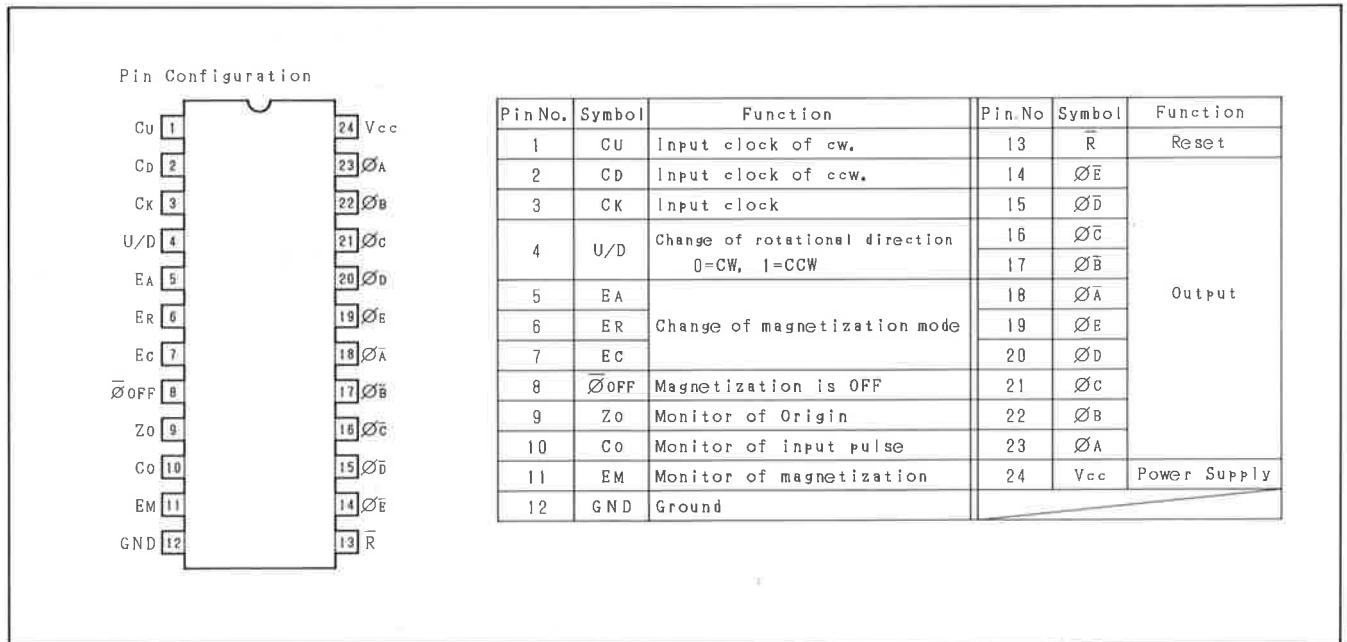

— IC DATA —

DAN601
DIODE ARRAY

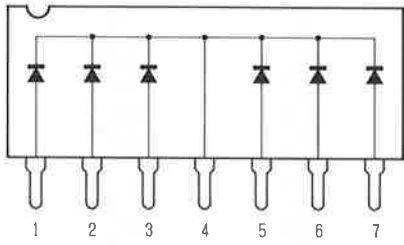

DAN 801

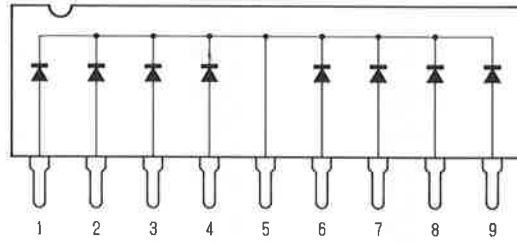

DAN201

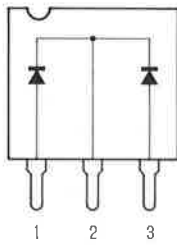

DAP201

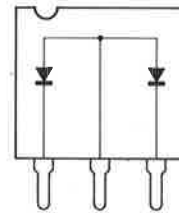

DTA series

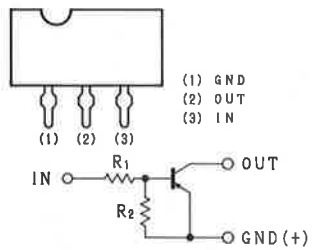

DTC, DTD series

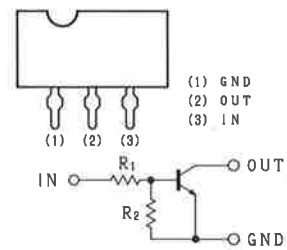

A B C D E F G H I J K

— SCHEMATIC DIAGRAM —

MAIN BOARD

● HOST CPU

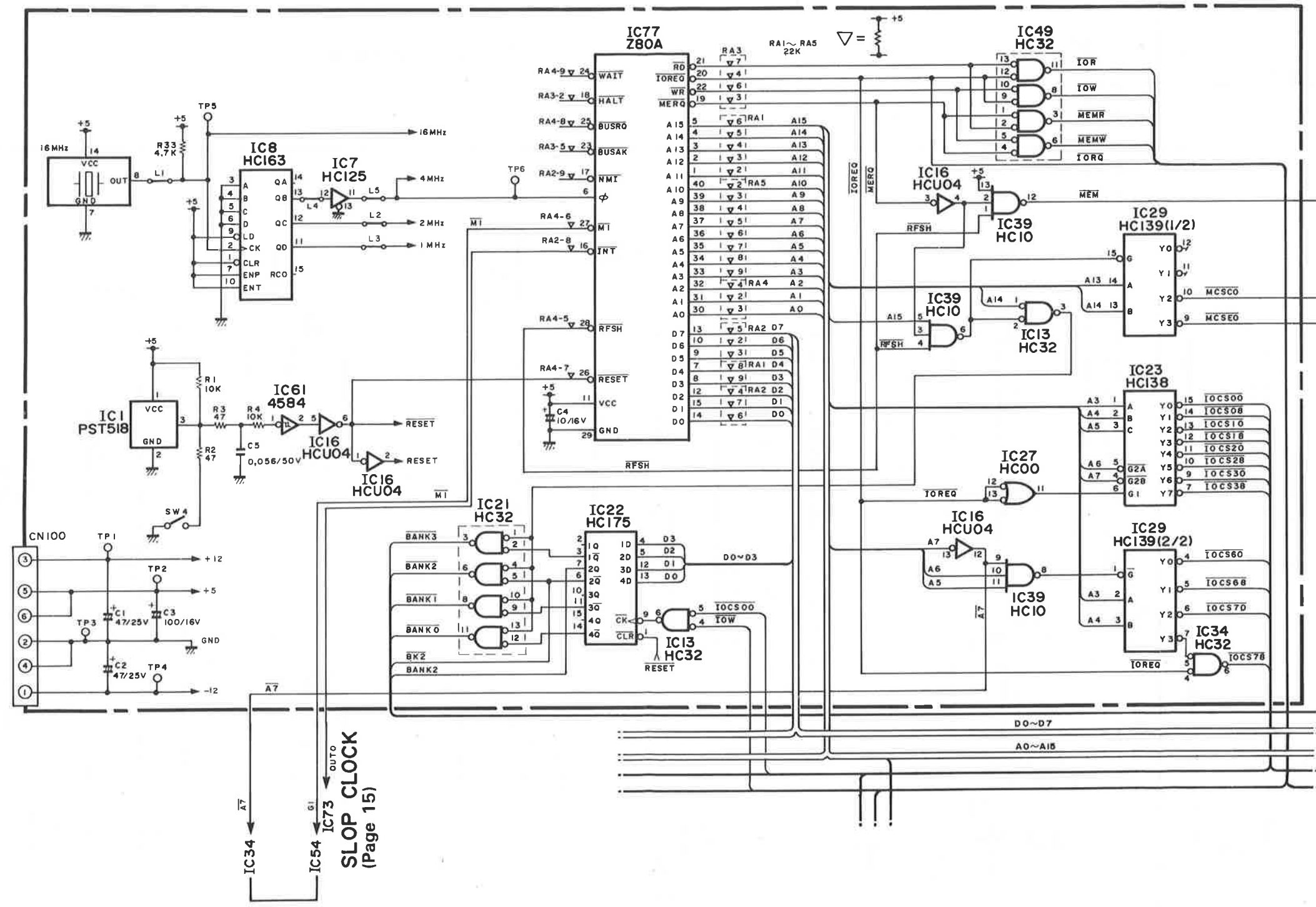

IC20
 MAIN MEMORY
 (Page 19)
 IC19
 IC80

IC34
 IC54
 KANJI IF
 (Page 25)
 SLOP CLOCK
 (Page 15)

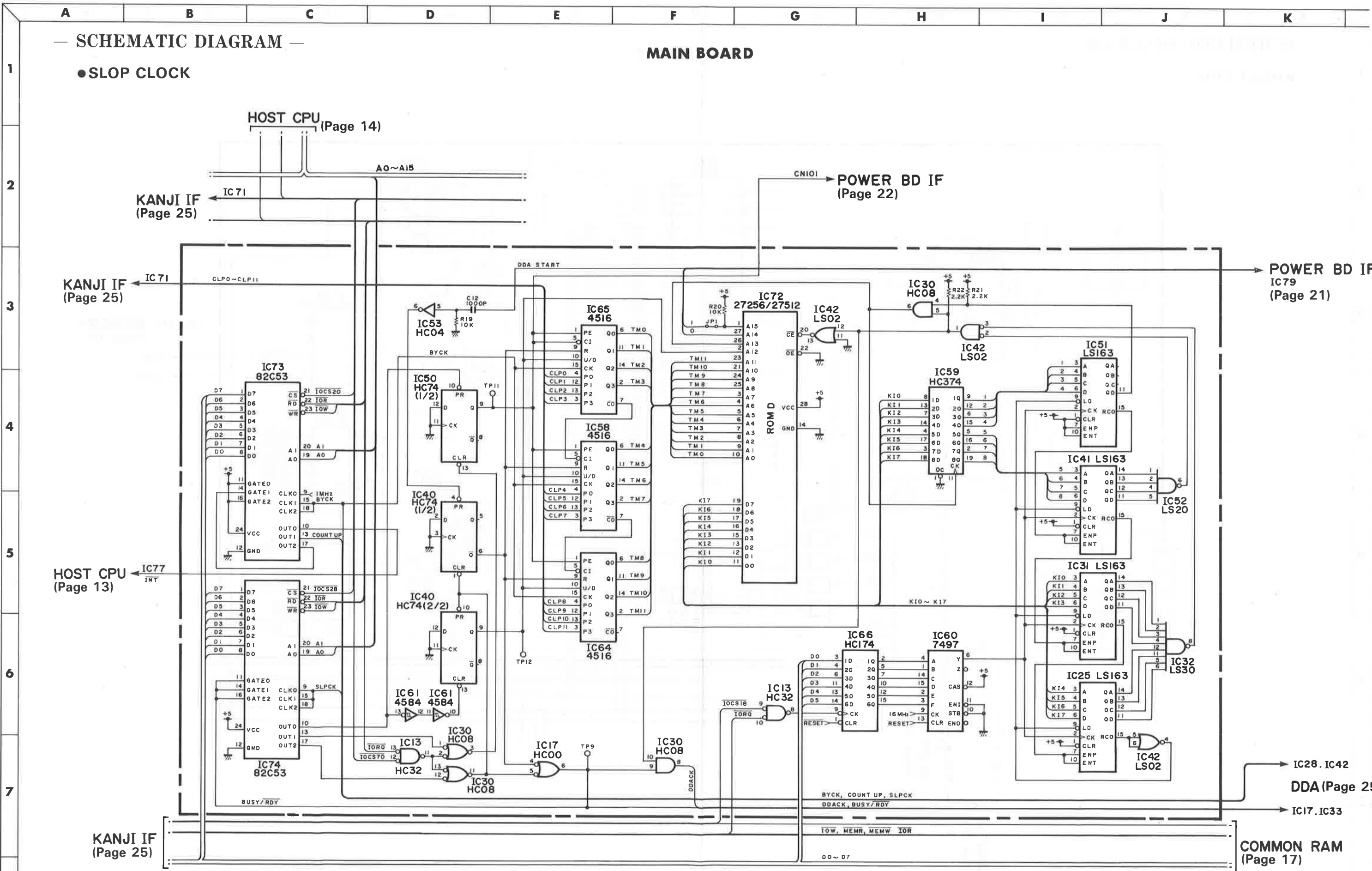

— SCHEMATIC DIAGRAM —

MAIN BOARD

● COMMON RAM

1
2
3
4
5
6
7

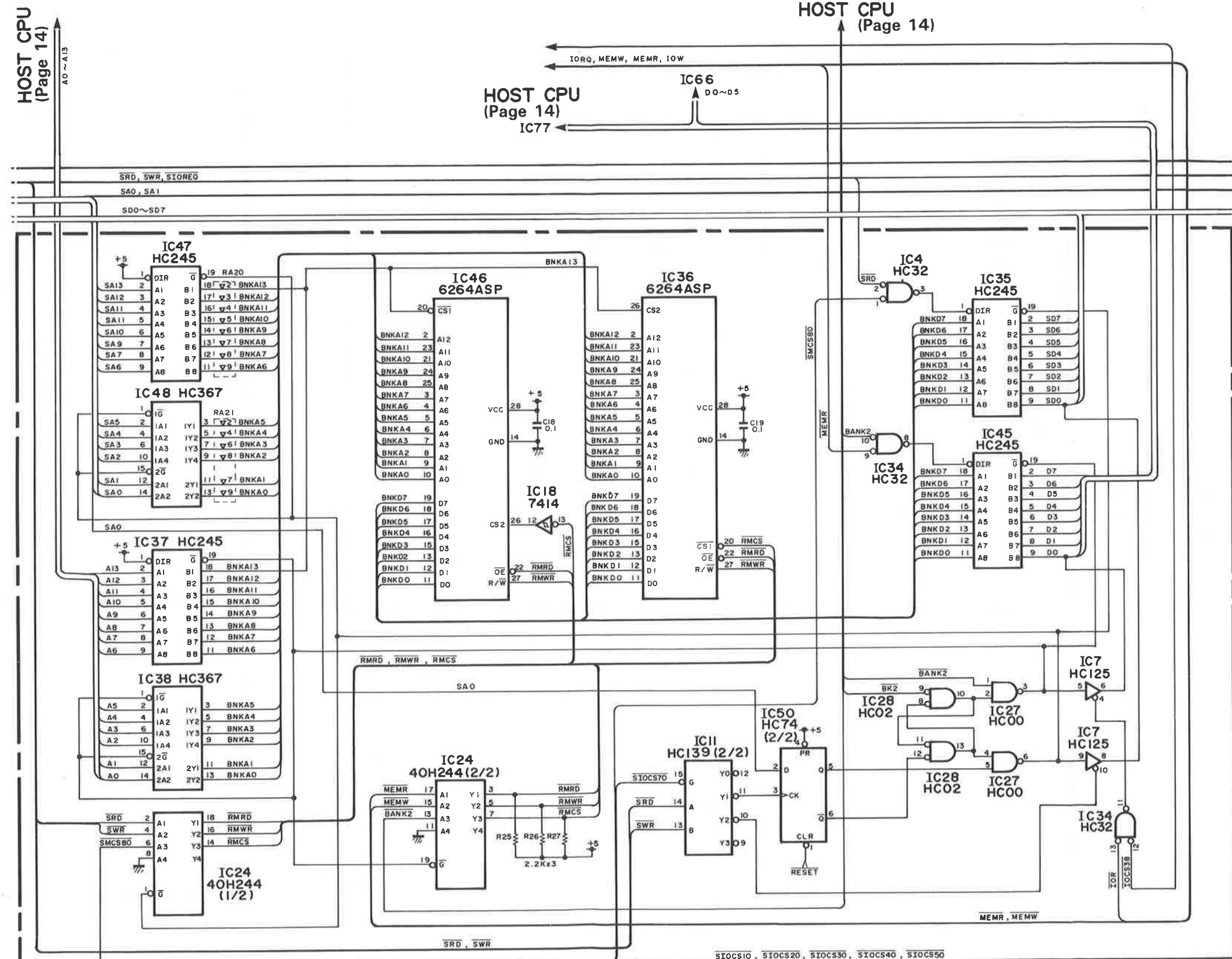

IC11, IC12
SUB CPU
(Page 24)

IOCS10, IOCS20, IOCS30, IOCS40, IOCS50

BIT SW (Page 20)
PIO / SIO IF
(Page 26)

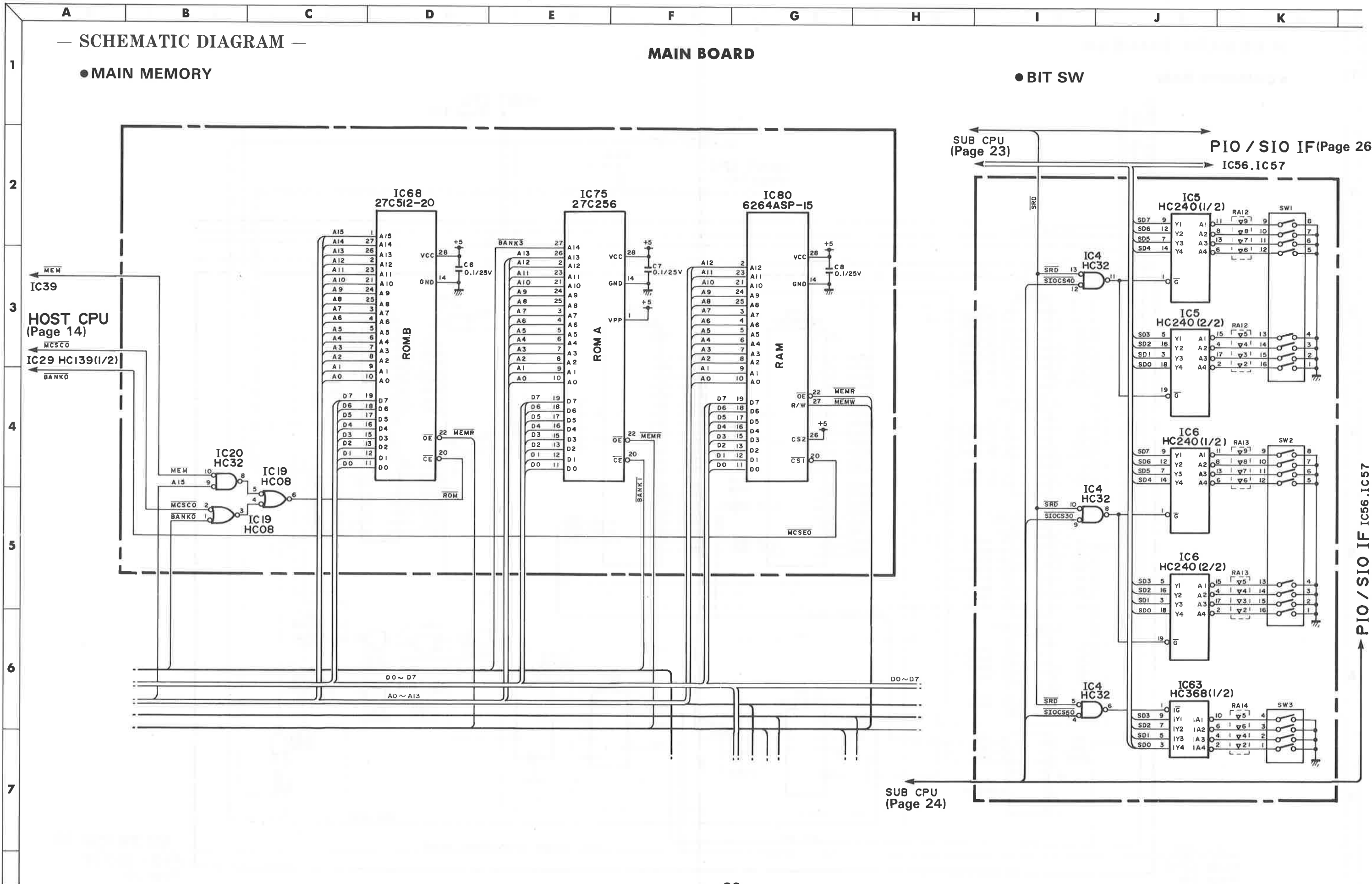

— SCHEMATIC DIAGRAM —

MAIN BOARD

● POWER BD IF

1
2
3
4
5
6
7

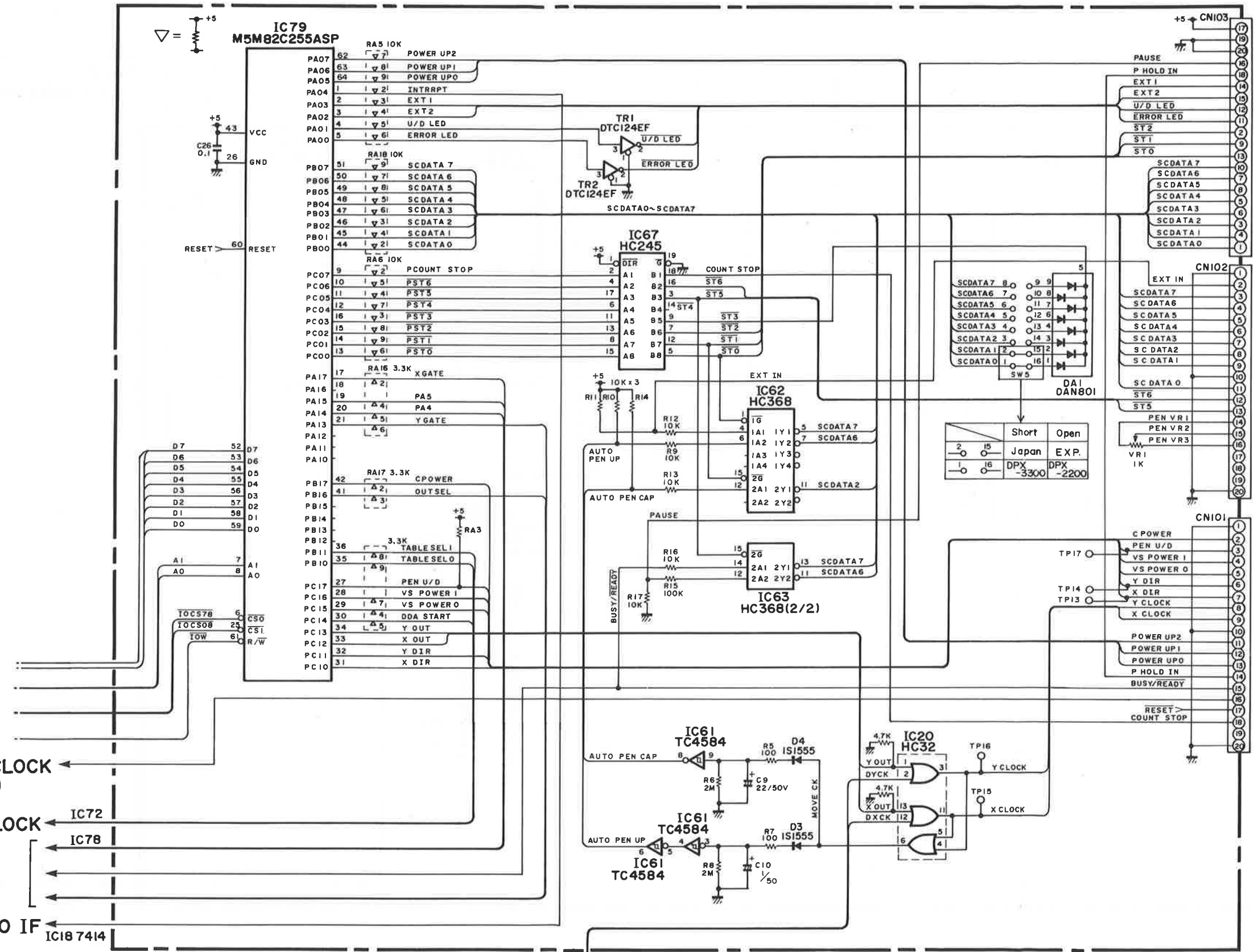

SLOP CLOCK ←
(Page 16)

SLOP CLOCK ← IC72
(Page 16)

DDA ← IC78
(Page 25)

PIO / SIO IF ← IC18 7414
(Page 26)

DDA ← IC16
(Page 25)

— SCHEMATIC DIAGRAM —

MAIN BOARD

● SUB CPU

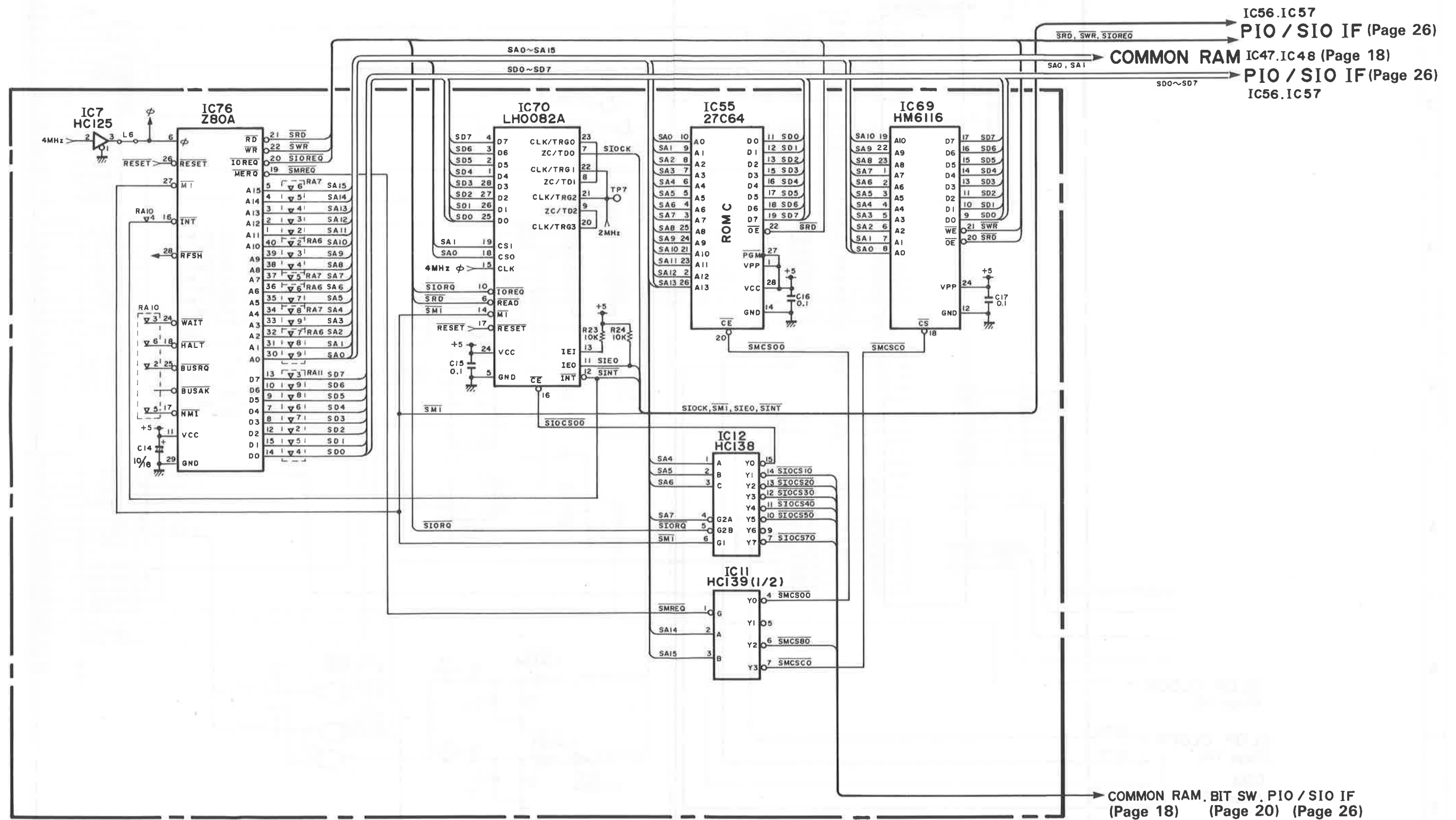

COMMON RAM, BIT SW, PIO / SIO IF (Page 18) (Page 20) (Page 26)

— SCHEMATIC DIAGRAM —

MAIN BOARD

● PIO/SIO IF

1
2
3
4
5
6
7

● DDA

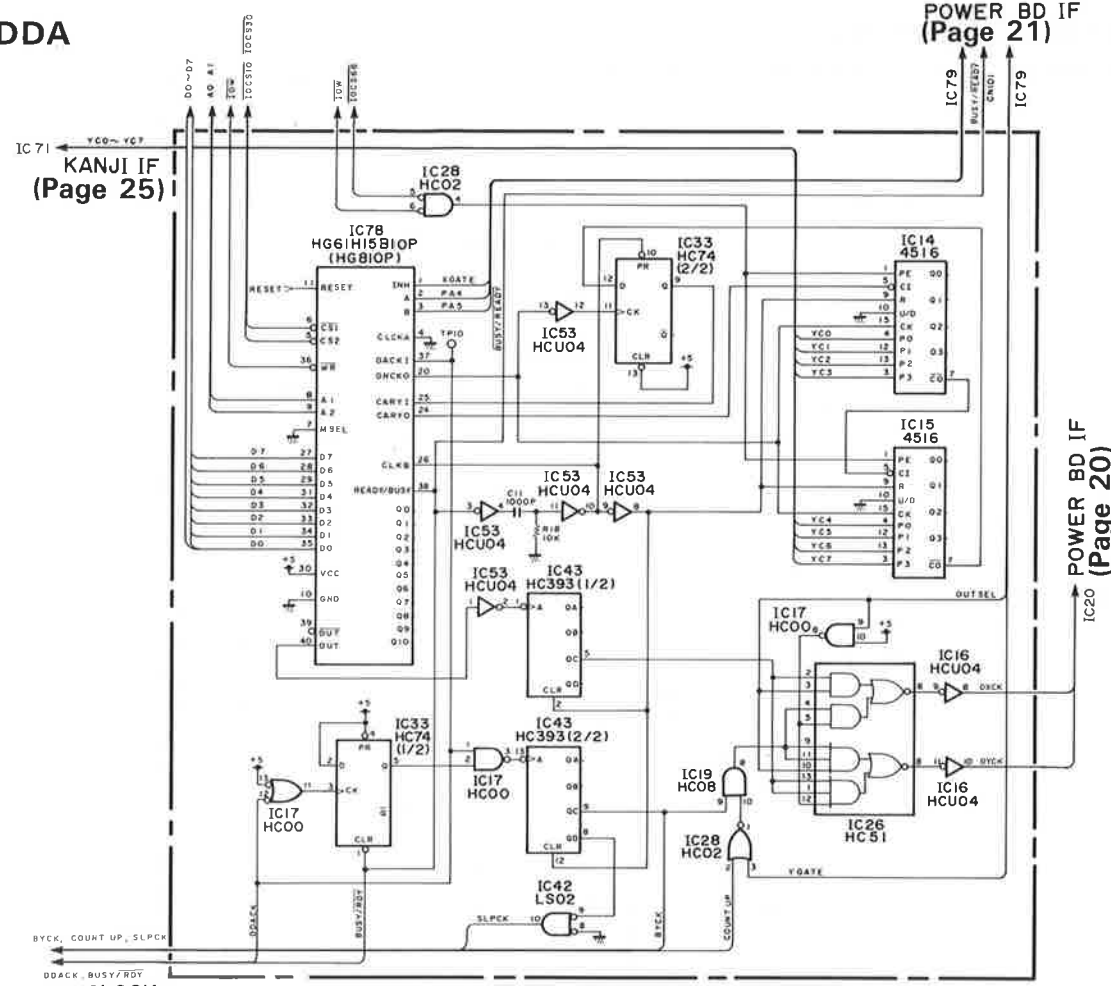

● KANJI IF

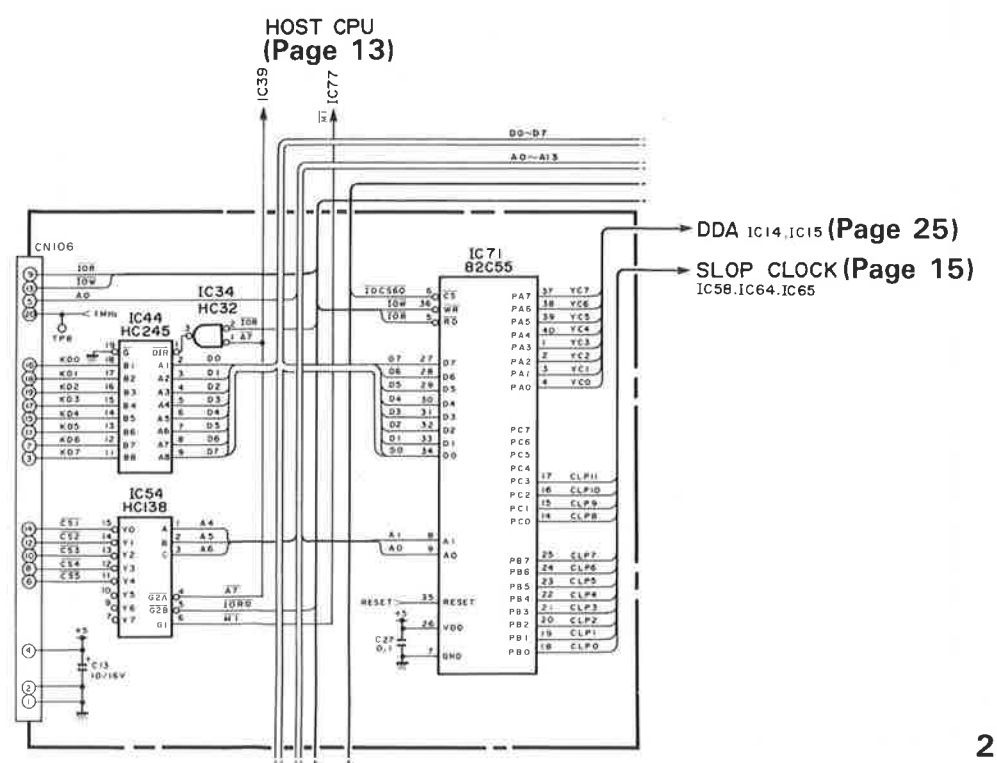

IC79
POWER BD IF (Page 21)

IC70
SUB CPU (Page 24)

SUB CPU (Page 24)

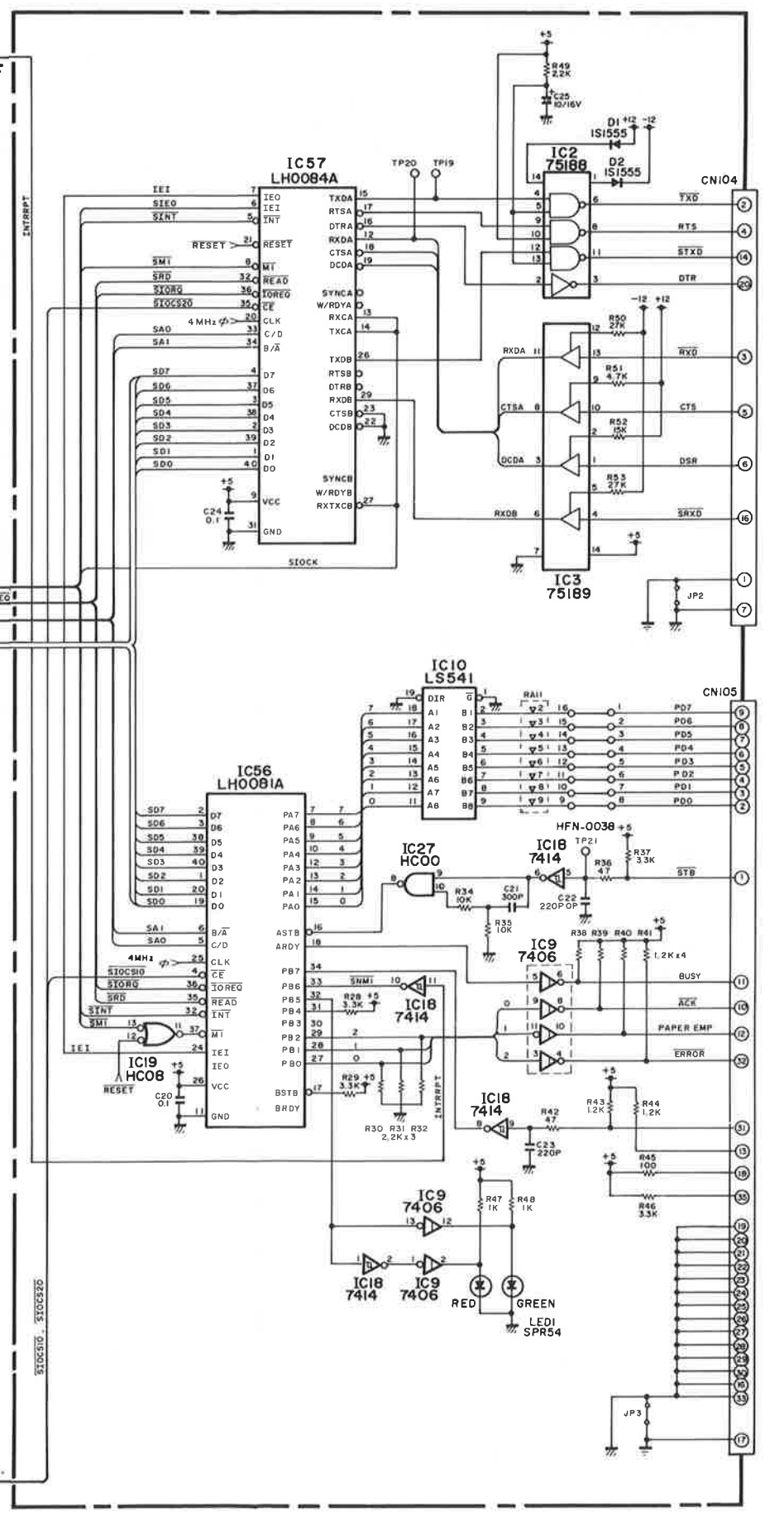

— SCHEMATIC DIAGRAM —

POWER BOARD

● MOTOR CONT

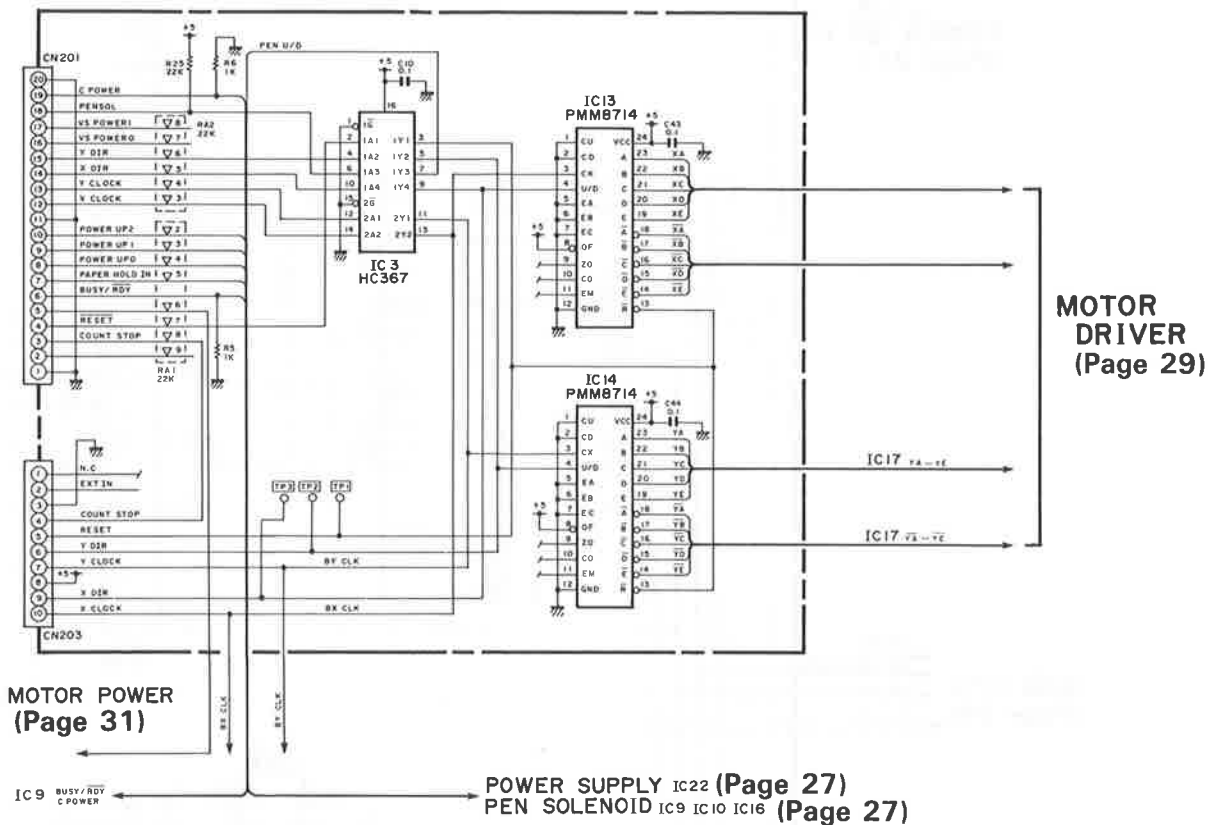

● PEN SOLENOID

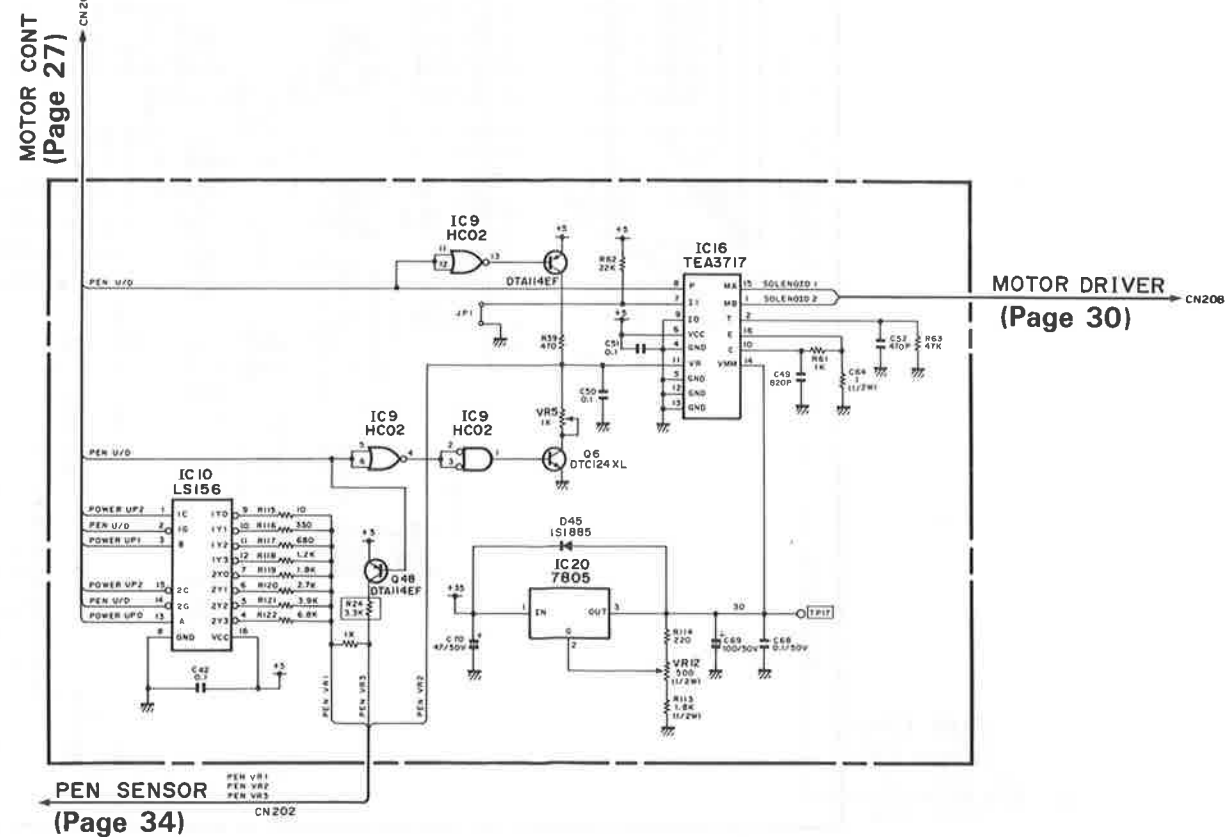

● POWER SUPPLY

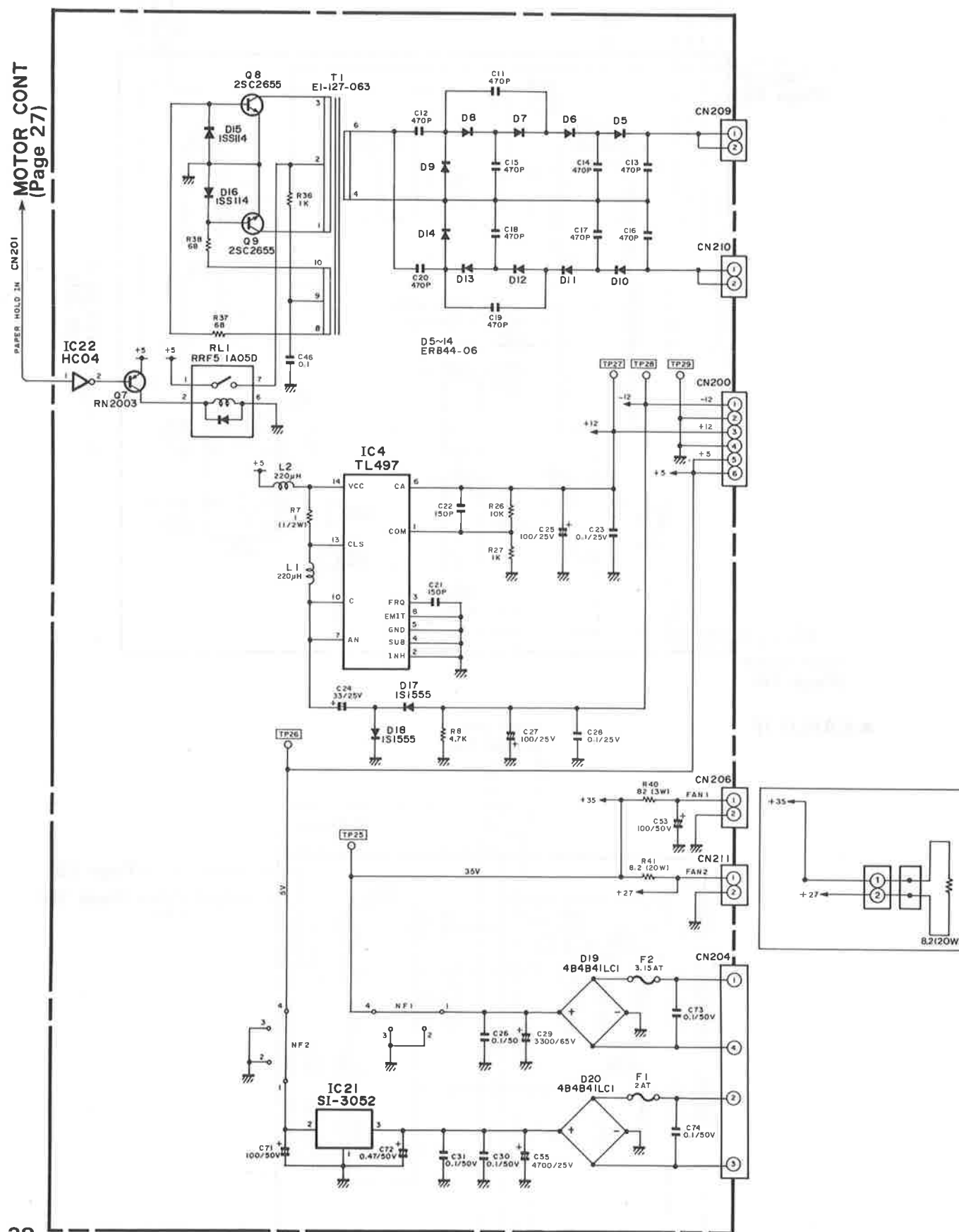

— SCHEMATIC DIAGRAM —

POWER BOARD

● MOTOR DRIVER

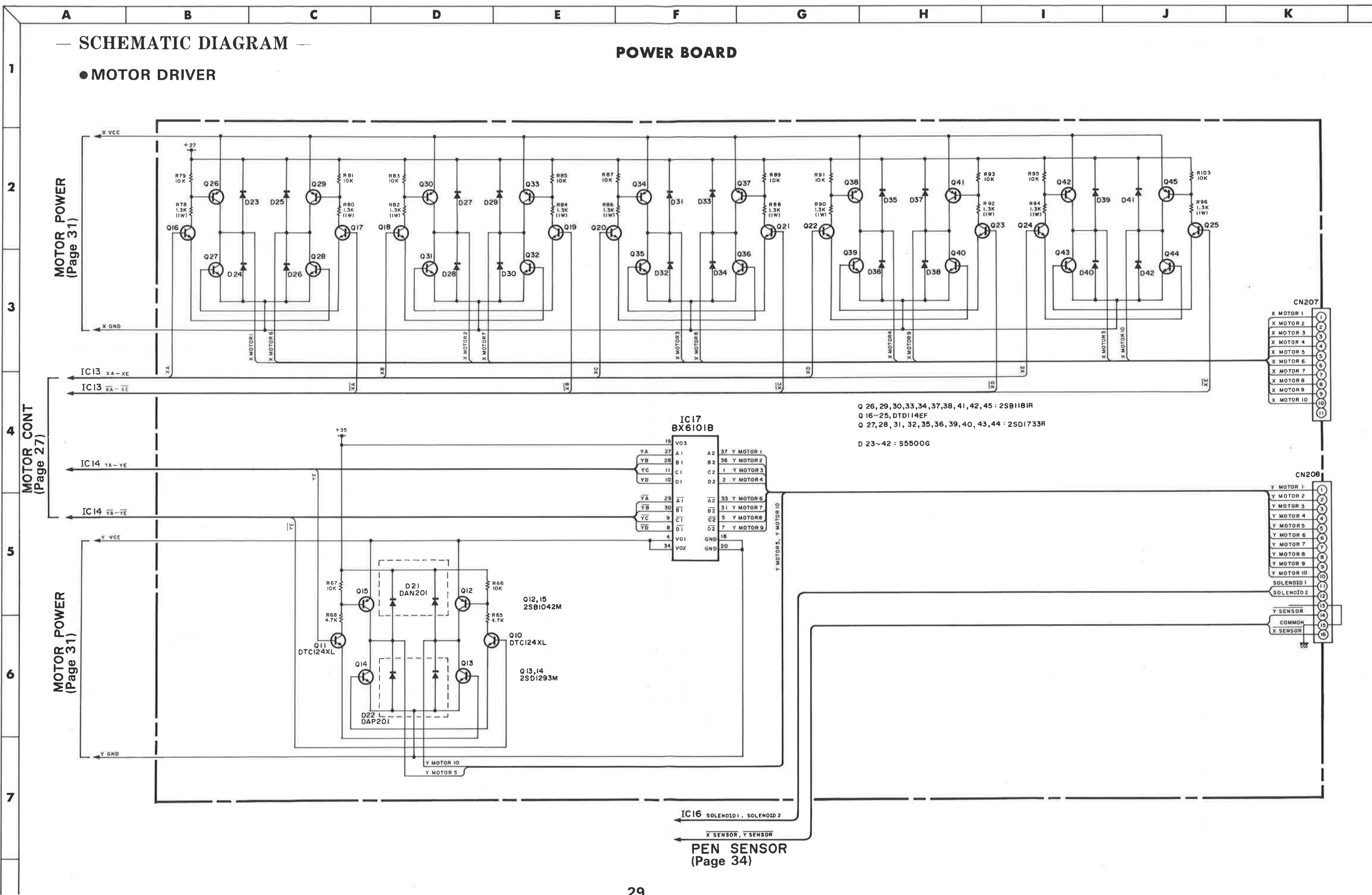

MOTOR POWER (Page 31)

MOTOR CONT (Page 27)

MOTOR POWER (Page 31)

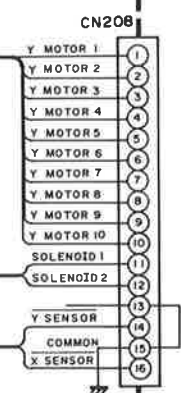
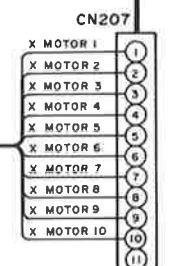

Q 26, 29, 30, 33, 34, 37, 38, 41, 42, 45 : 2SB1181R
 Q 16~25, DTD114EF
 Q 27, 28, 31, 32, 35, 36, 39, 40, 43, 44 : 2SD1733R
 D 23~42 : S5500G

IC16 SOLENOID 1, SOLENOID 2
 X SENSOR, Y SENSOR
 PEN SENSOR (Page 34)

A B C D E F G H I J K

— SCHEMATIC DIAGRAM —

POWER BOARD

● MOTOR POWER

MOTOR CONT (Page 27)

PEN SOLENOID (Page 27)

MOTOR DRIVER (Page 29)

MOTOR DRIVER (Page 29)

MOTOR DRIVER (Page 29)

MOTOR DRIVER (Page 29)

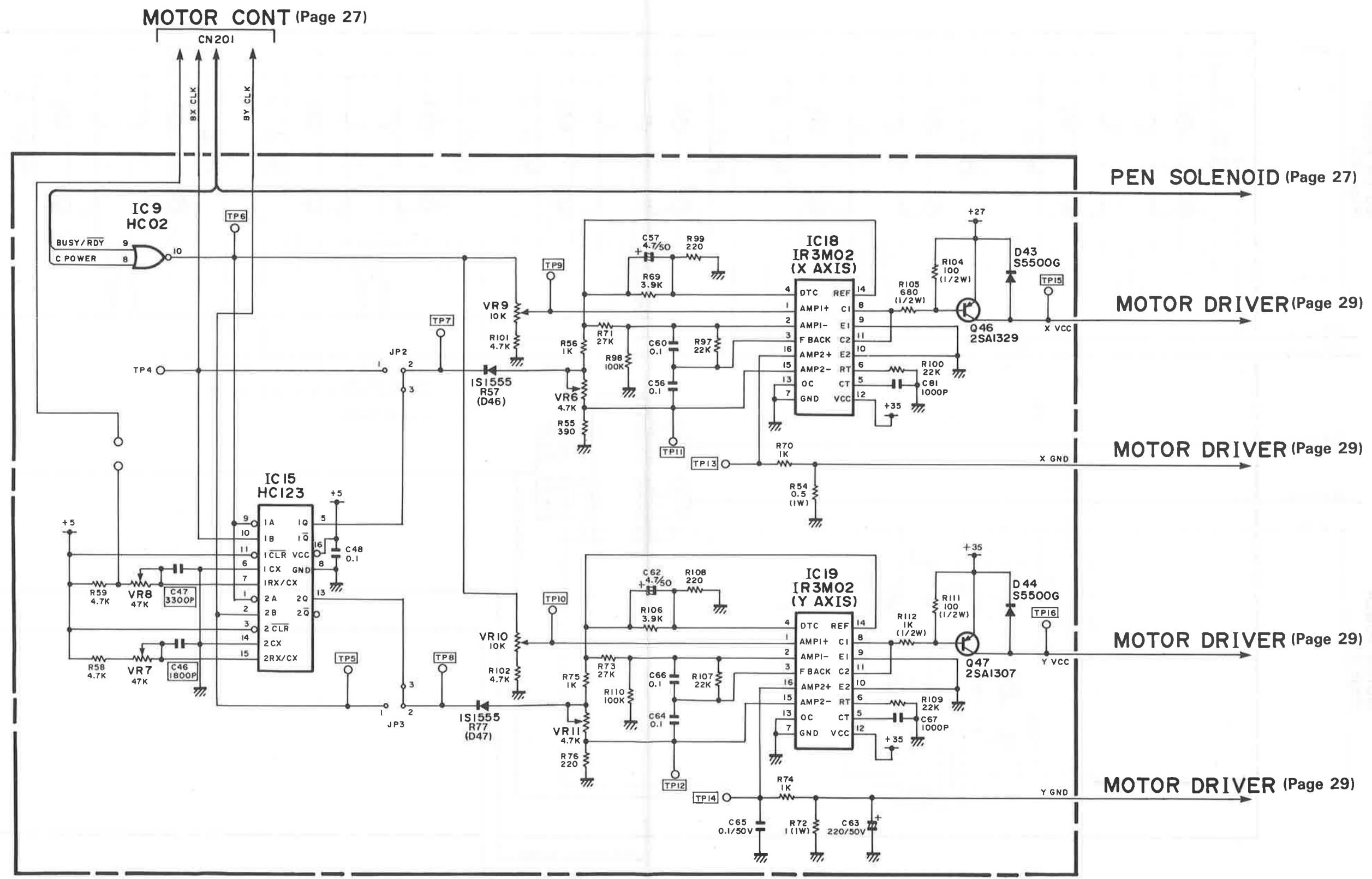

A B C D E F G H I J K

— SCHEMATIC DIAGRAM —

POWER BOARD

● PEN SENSOR

1
2
3
4
5
6
7

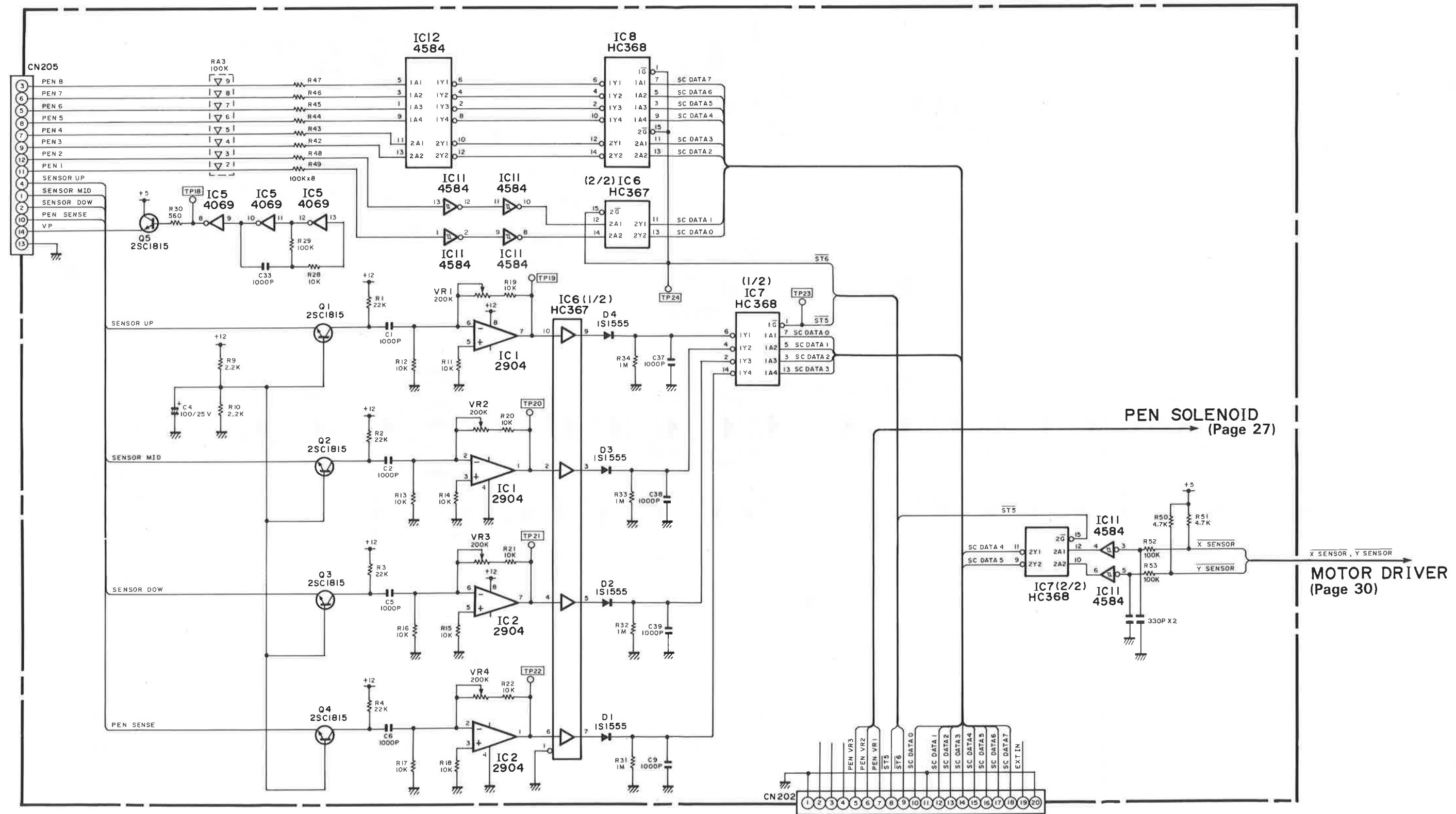

— SCHEMATIC DIAGRAM —

PANEL BOARD

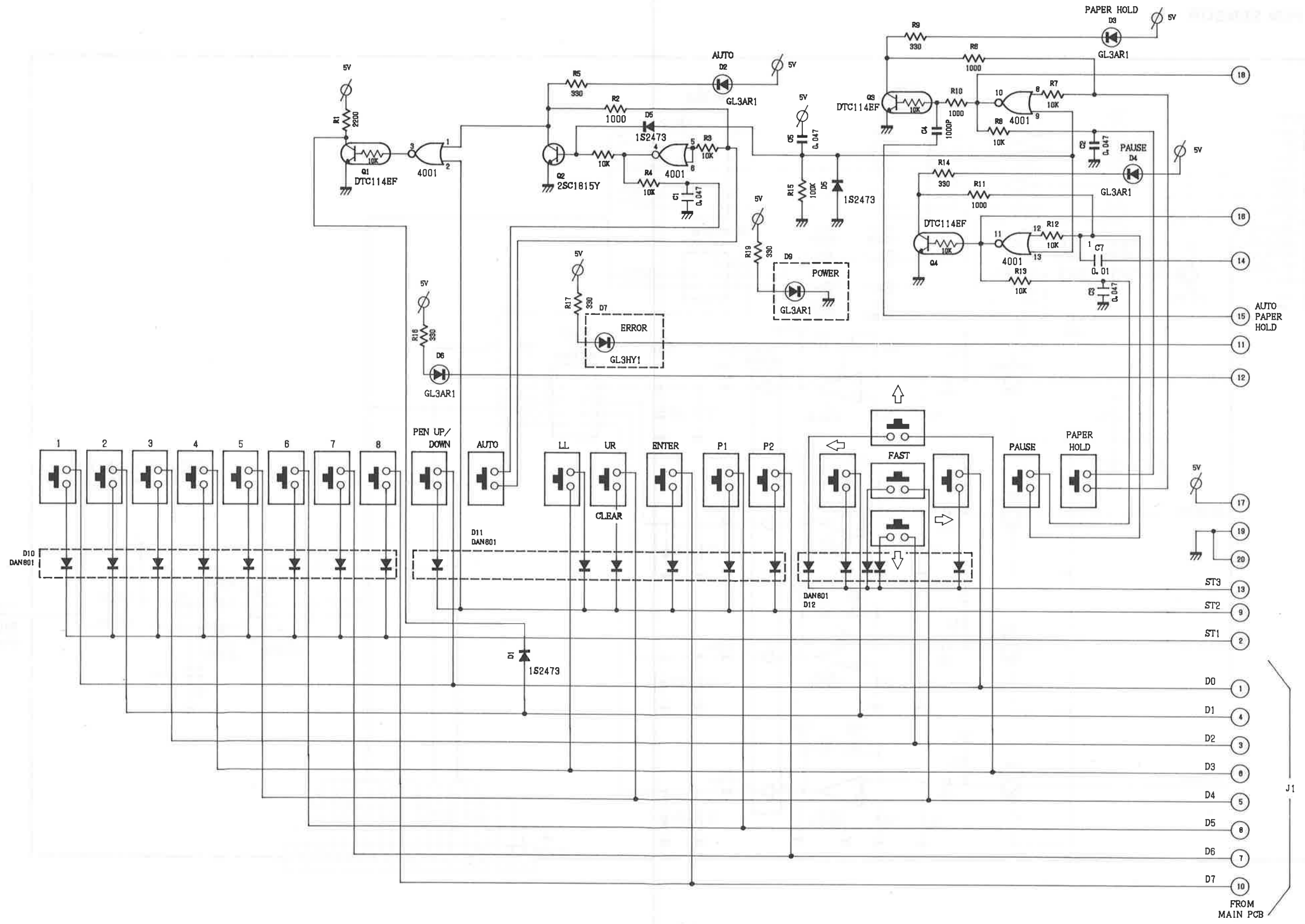

— SCHEMATIC DIAGRAM —

COUNTER BOARD

1
2
3
4
5
6
7

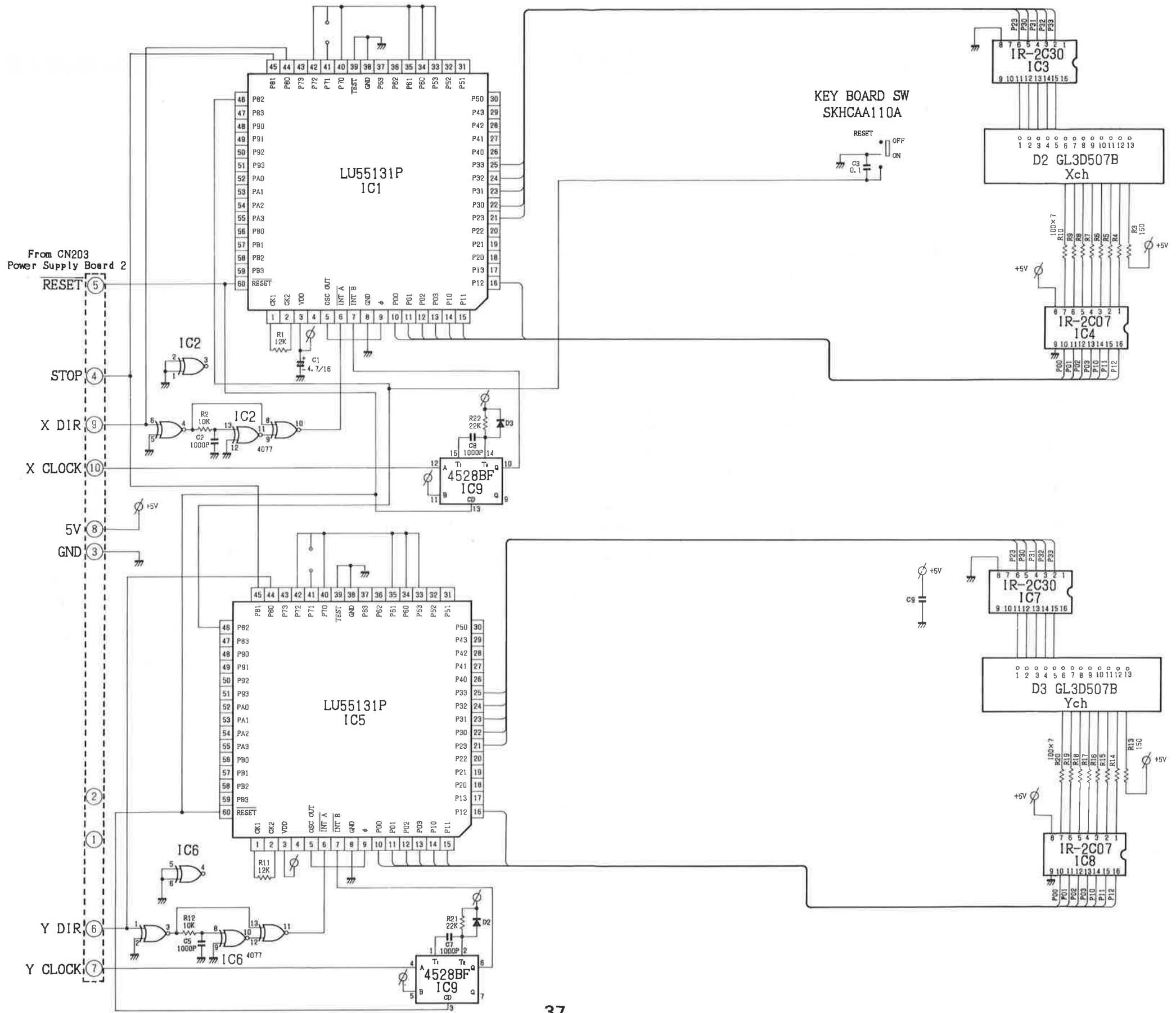

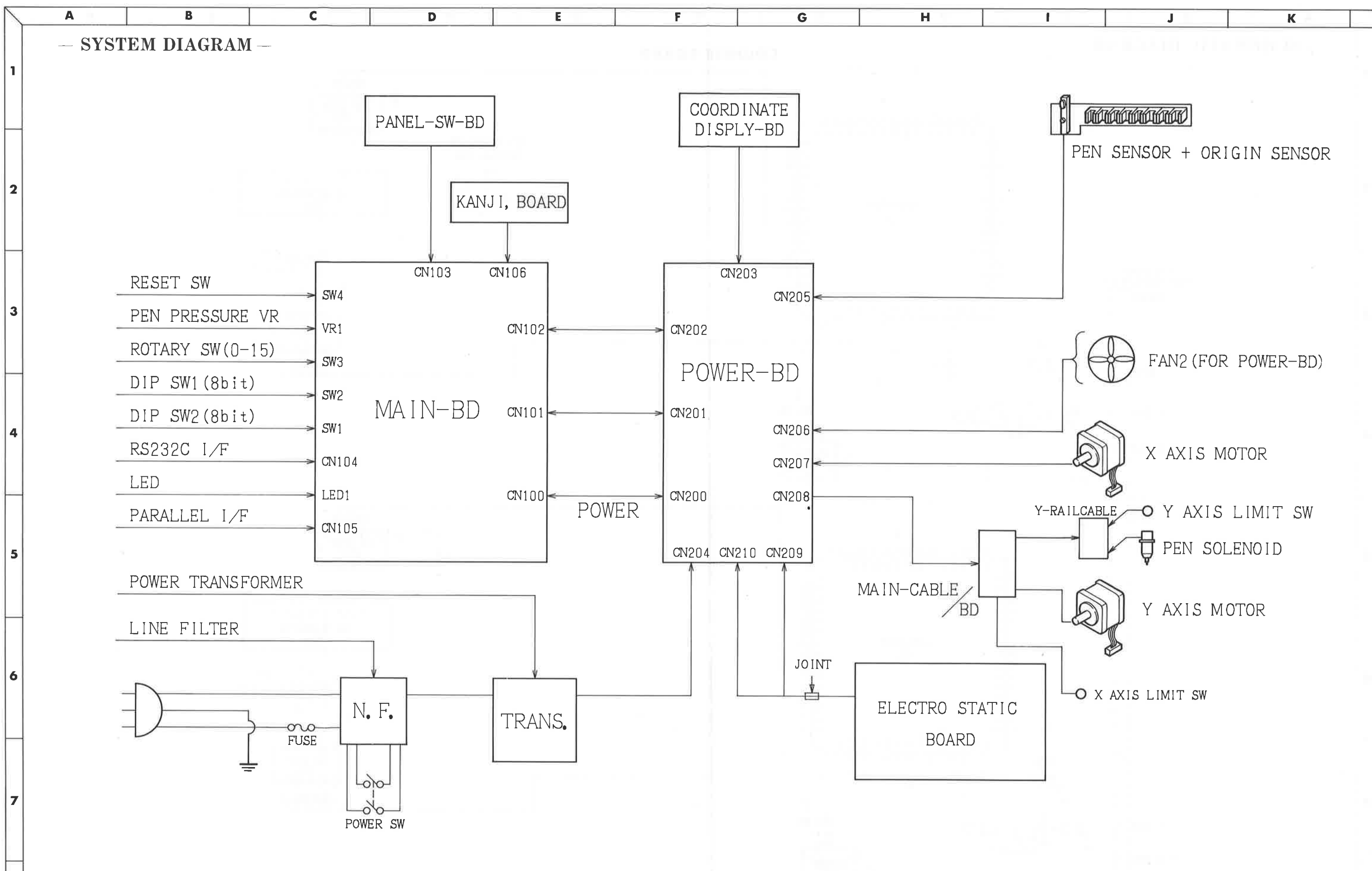

A B C D E F G H I J K

CIRCUIT BOARD

MAIN BOARD

1
2
3
4
5
6
7

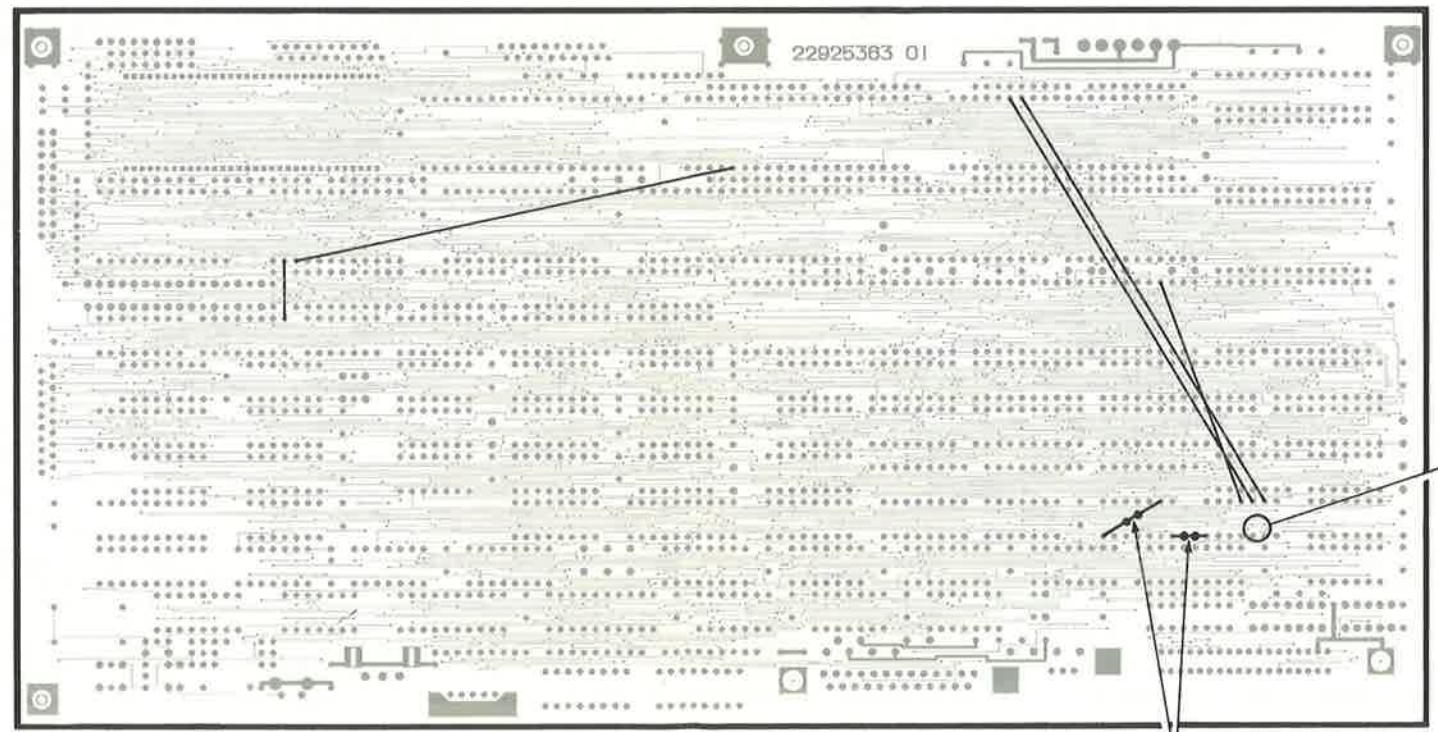
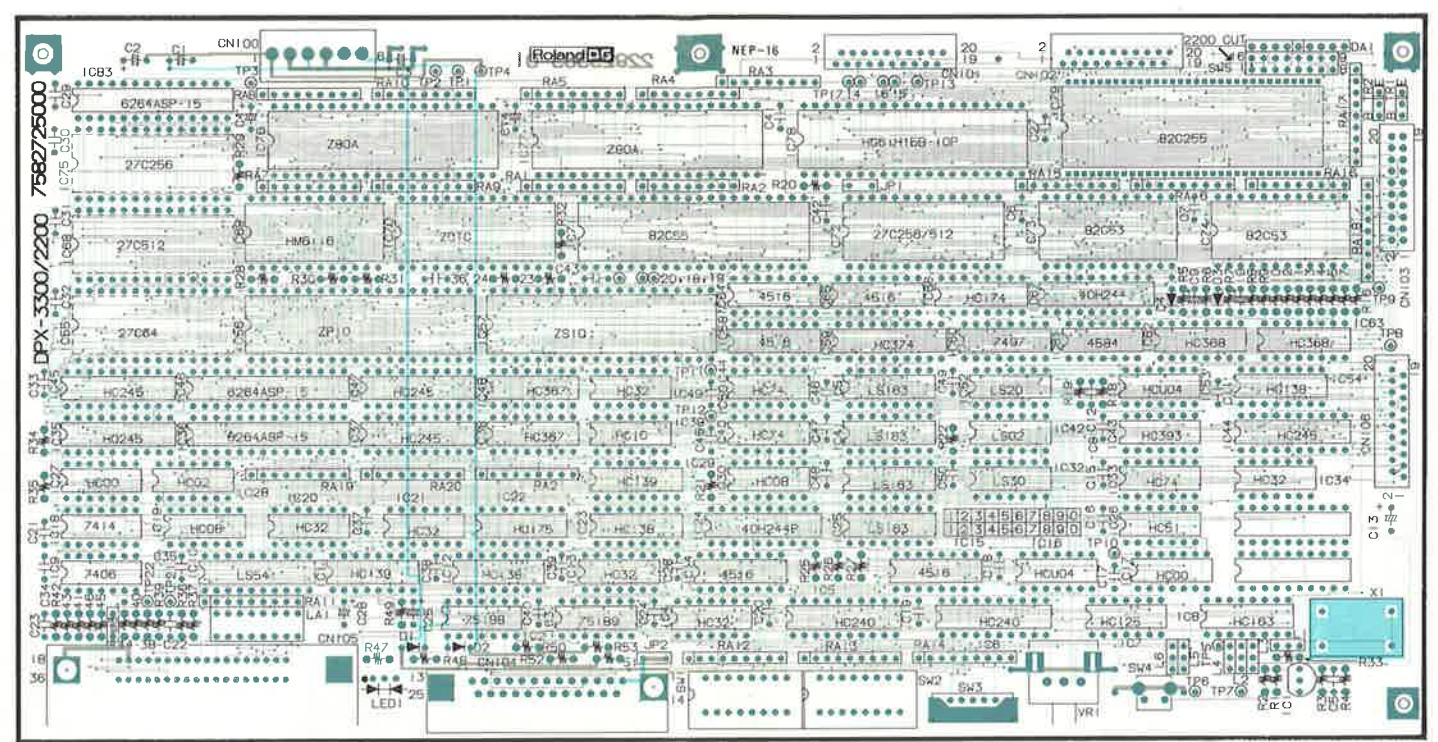

View from foil side

Resistor 4.7 KΩ

A B C D E F G H I J K

— CIRCUIT BOARD —

POWER BOARD

1
2
3
4
5
6
7

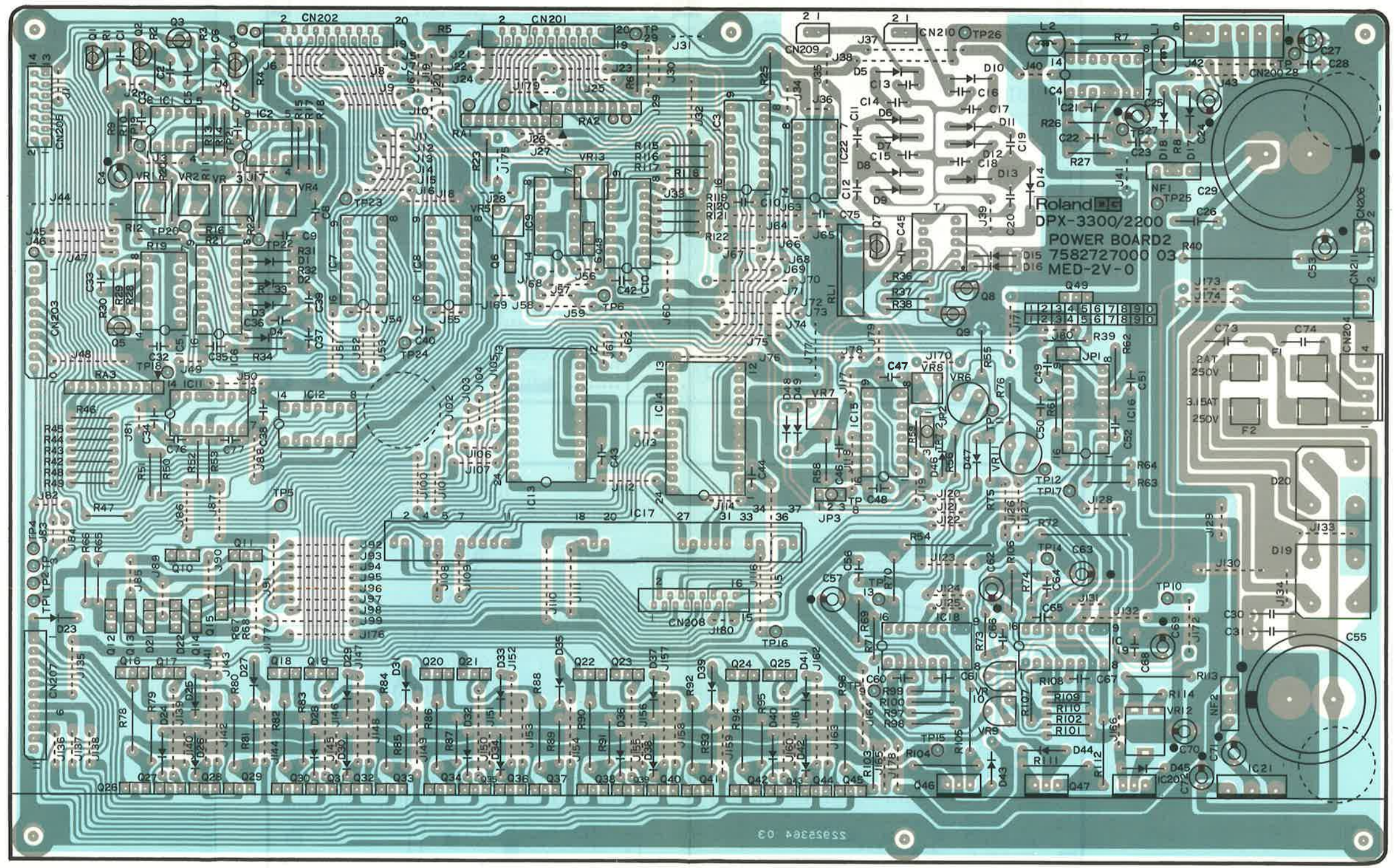

A B C D E F G H I J K

CIRCUIT BOARD

PANEL BOARD

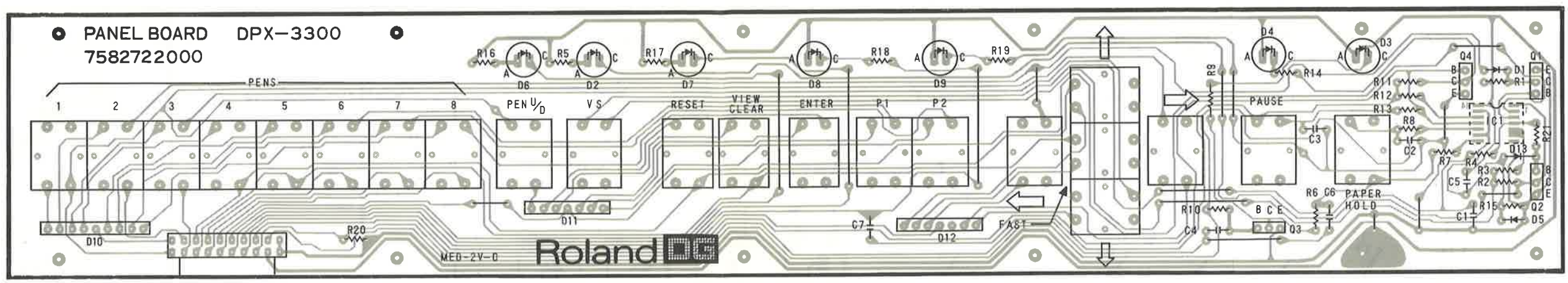

COUNTER BOARD

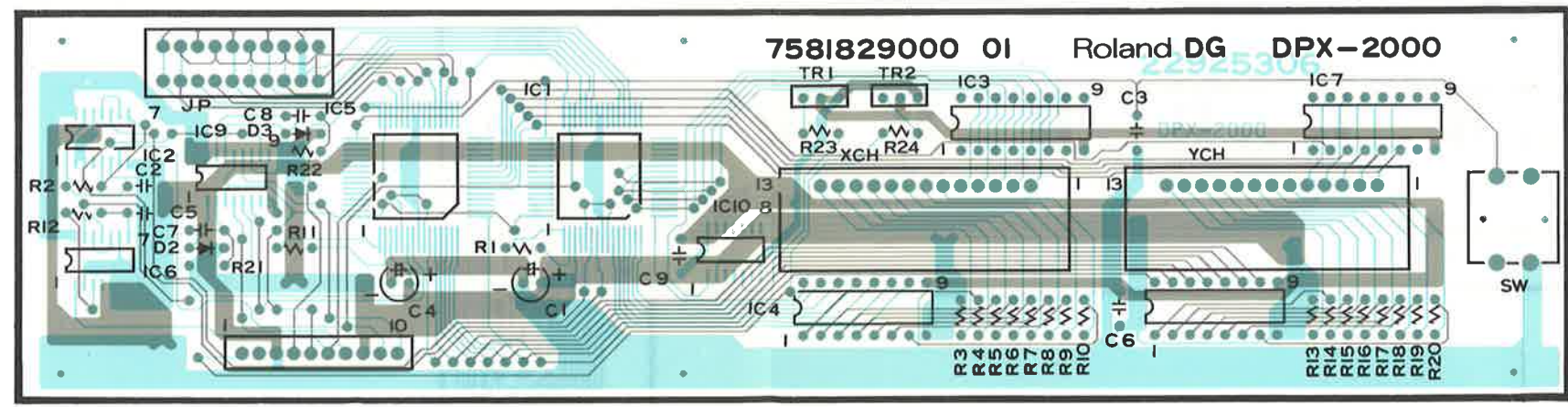

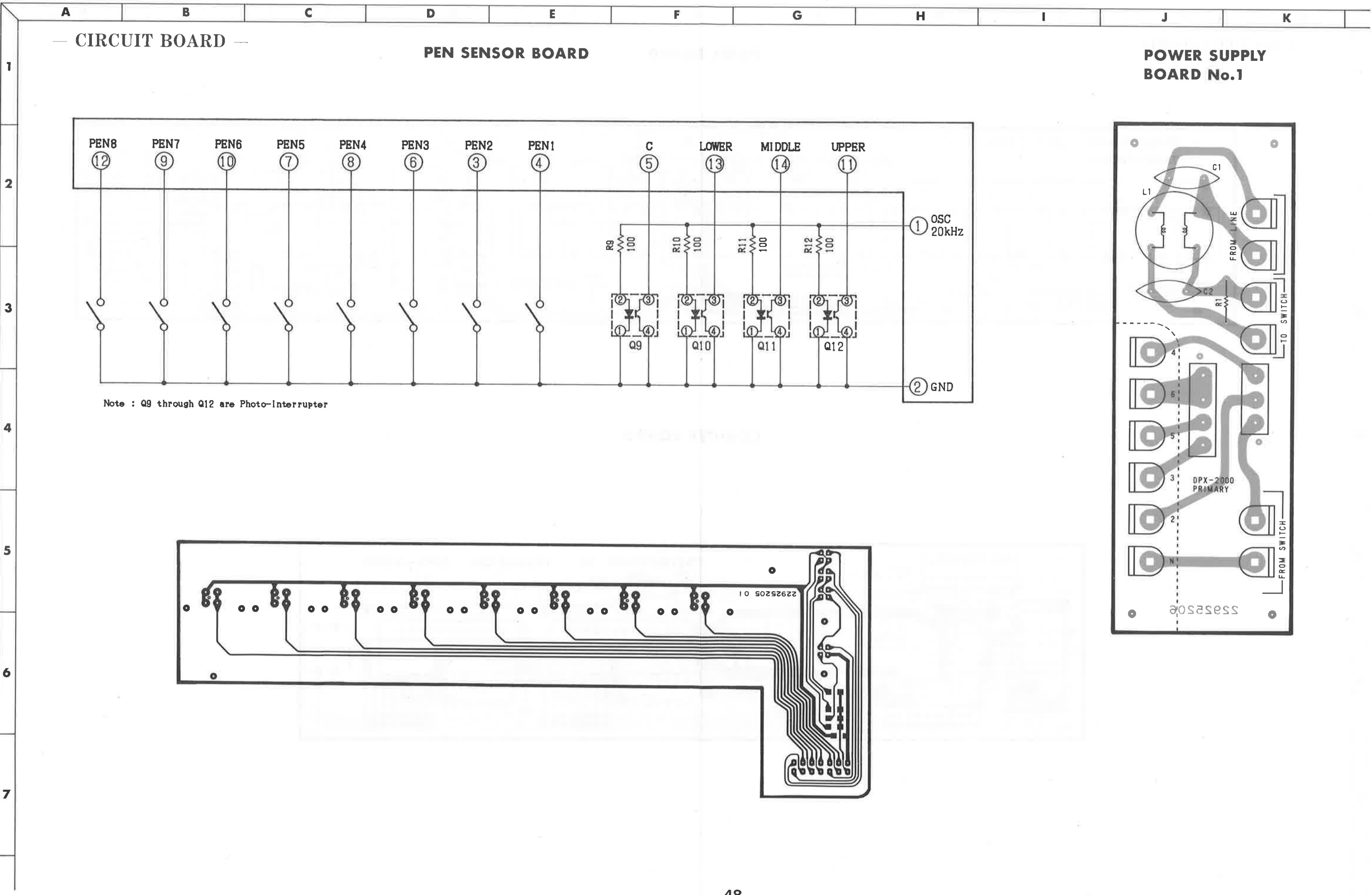

CIRCUIT BOARD

PEN SENSOR BOARD

POWER SUPPLY BOARD No.1

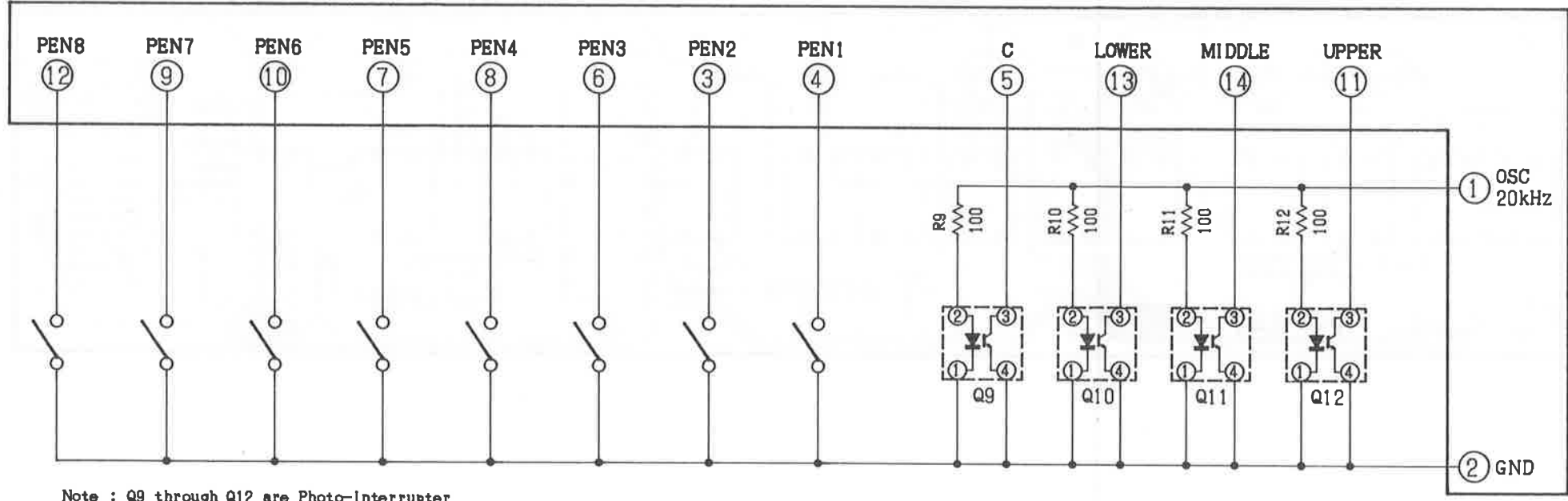

Note : Q9 through Q12 are Photo-Interrupter

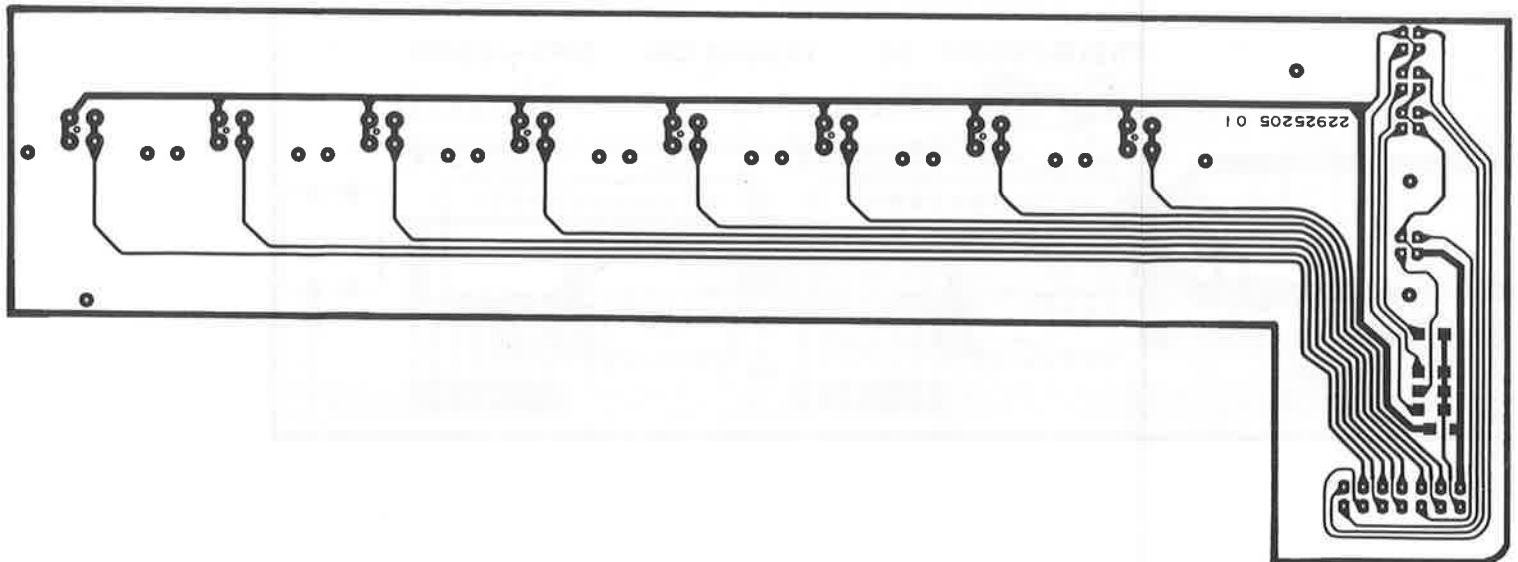
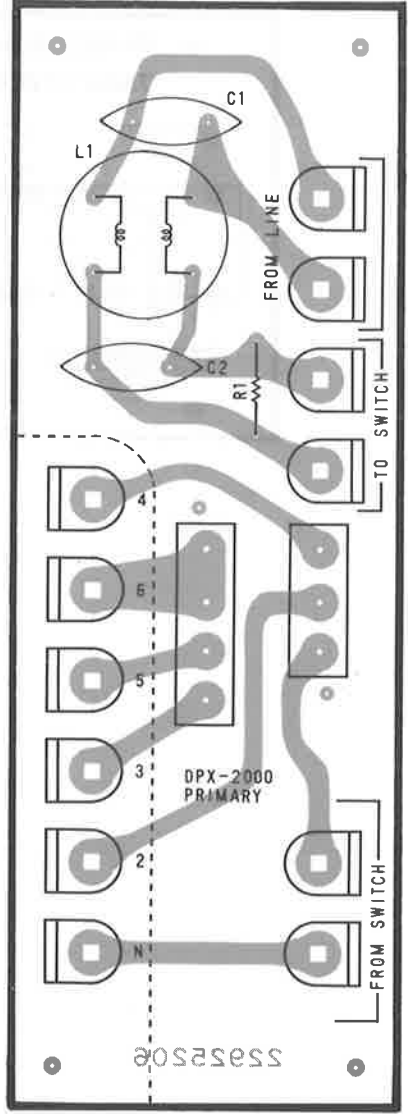

— ELECTRICAL PARTS LIST —

Ref. No.	Parts No.	Description
MAIN BOARD		
	<u>7582725000</u>	<u>Main Board Ass'y</u>
LSI		
IC76, 77	15179219	TMPZ84C00P (Z80A CPU)
IC79	15179257	M5M82C255ASP
IC71	15179195	MSM82C55A-5RS
IC73, 74	15179185	MSM82C53-5
IC56	15179216	LH-0081A (Z80A PIO)
IC70	15179217	LH-0082A (Z80A CTC)
IC57	15179218	LH-0084A (Z80A SIO)
IC36, 46, 83	15179369	HM6264ASP-15 (64KB SRAM)
IC69	15179322	HM6116P-4 (16KB SRAM)
IC78	15229847	HG61H15B•10P (DDA)
EPROM		
IC75	15449114	ROM A FONT (64KB)
IC68	15449115	ROM B MAIN (32KB)
IC55	15449116	ROM C I/O (8KB)
IC72	15449117	ROM D TRP (64KB)
IC		
IC17, 27	15169515	TC74HC00P
IC28	15169516	TC74HC02P
IC16, 53	15169512T0	TC74HCU04P
IC19, 30	15169547T0	TC74HC08P
IC39	15169568	TC74HC10P
IC4, 13, 20, 21, 34, 49	15169549T0	TC74HC32P
IC26	15169532	TC74HC51P
IC33, 40, 50	15169513	TC74HC74P
IC7	15169565	TC74HC125P
IC12, 23, 54	15169550T0	TC74HC138P
IC11, 29	15169539	TC74HC139P
IC8	15169561	TC74HC163P
IC66	15169551	TC74HC174P
IC22	15169562	TC74HC175P
IC5, 6	15169566	TC74HC240P
IC35, 37, 44, 45, 47	15169552T0	TC74HC245P
IC38, 48	15169553T0	TC74HC367P
IC62, 63	15169567	TC74HC368P
IC59	15169554T0	TC74HC374P
IC43	15169555T0	TC74HC393P
IC2	15219144H0	HD75188P
IC3	15219145H0	HD75189P
IC1	15219139	PST-518A
TR1, 2	15129147	DTC124EF
IC14, 15, 58, 64, 65	15159318T0	TC4516BP
IC61	15159303T0	TC4584BP
IC24, 67	15159537	TC40H244P

— ELECTRICAL PARTS LIST —

Ref. No.	Parts No.	Description
TTL		
IC9	15169102HO	HD7406P
IC18	15169121	HD7414P
IC60	15169122	SN7497N
IC42	15169303HO	HD74LS02P
IC52	15169335BO	M74LS20P
IC32	15169308BO	M74LS30P
IC25, 31, 41, 51	15169368BO	M74LS163AP
IC10	15169359XO	SN74LS541N
DIODE & DIODE ARRAY		
DA1	15019142	DAN801
D1-4	15019101	1S1555
RESISTOR ARRAY		
RA6, 15, 18	13919310	RMLS8-103J (10K × 8)
RA1-5, 7-10		
12-14, 19-21	13919311	RMLS8-223J (22K × 8)
RA11, 16, 17	13919161	RMLS8-332J (3.3K × 8)
POTENTIOMETER		
VR1	13279817	EVJELAE02B13 (1 Kohm)
CONNECTOR		
CN103	13439175	FCN724P020-AU/L (20 Pin)
CN100	13439293	5273-06A (6 Pin)
CN102, 103, 106	13439325	HLEM20S-1 (20 Pin)
CN105	13429186	36 Pin Parallel connector
CN104	13429183	25 Pin serial connector
OTHERS		
SW4	13169665	Tact switch (Reset)
LED1	15029200	LED (Red or Green)
	13429527JO	IC socket (28 Pin)
SW3	13169658	DIGITAL switch (Baud rate)
SW1, 2	13169662	DIP switch DYS-8
X1	12389772	X'tal 16MHz

— ELECTRICAL PARTS LIST —

Ref. No.	Parts No.	Description
COUNTER BOARD		
	<u>7582723000</u>	<u>Counter Board Ass'y</u>
IC		
IC1, 5	15179238	CPU LU55131P
IC2, 6	15159150	TC4077BF
IC9	15159319	TC4528BF
IC10	15159149	TC4024BF
TRANSISTOR ARRAY		
IC3, 7	15149120	IR2C30
IC4, 8	15149125	IR2C07
LED & DIODE		
D2, 3	15019103 15029184	1S2473 LED GL3D507B
MISCELLANEOUS		
	13129715 23495536 13619302NO	Switch SKHCAA110A Wiring Ass'y Tantalum cap. 4.7MF/16V
PANEL BOARD		
	<u>7582722000</u>	<u>Panel Board Ass'y</u>
SEMICONDUCTORS		
D1, 5, 13	15019103	1S2473 (DIODE)
D10	15019142	DAN801 (DIODE ARRAY)
D11, 12	15019151	DAN601 (DIODE ARRAY)
D2-4, 6, 9	15029110	GL-3AR1 (LED red)
D7	15029201	GL-3HY1 (LED yellow)
Q2	15129115	2SC1815Y (TRANSISTOR)
Q1, 3, 4	15129150	DTC114EF (DIGITAL TRANSISTOR)
IC1	15159146	TC4001BF (CMOS IC)
MISCELLANEOUS		
	13129715 23495561	Switch SKHCAA110A Wiring (Panel↔Main)
POWER SUPPLY BOARD No. 1		
	<u>758182500</u>	<u>Power Supply Board No.1 Ass'y</u>
	13529104	Capacitor of line bypass
	12449244	Line Filter Coil
	13819261	Resistor 470 Kohm 1/2W
	13429172	Connector 3 Pin
	13429173	Connector 4 Pin

— ELECTRICAL PARTS LIST —

Ref. No.	Parts No.	Description
POWER SUPPLY BOARD No.2		
	<u>7582727000</u>	<u>Power board No.2 ass'y</u>
IC		
IC5	15159116T0	TC4069UBP
IC11, 12	15159303T0	TC4584BP
IC10	15169342B0	M74LS156P
IC22	15169514	TC74HC04P
IC9	15169516	TC74HC02P
IC3, 6	15169553T0	TC74HC367P
IC15	15169560	TC74HC123P
IC7, 8	15169567	TC74HC368P
IC1, 2	15189134	NJM2904D
IC20	15199106T0	TA78005AP
IC18, 19	15199131P0	IR3M02
IC21	15199143	SI-3052V
IC4	15199519	TL497ACN
IC16	15199539	TEA3717
IC13, 14	15219156	PMM8714
IC17	152298210B	BX-6101B
TRANSISTOR		
Q48, 49	15119133	DTA114EF
Q12, 15	15119612	2SB1042M-R
Q47	15119412	2SA1307Y
Q46	15119415	2SA1329Y
Q26, 29, 30, 33, 34, 37, 38, 41, 42, 45	15119613	2SB1181R
Q1-5	15129115	2SC1815Y
Q8, 9	15129162	2SC2655Y
Q7	15129173	RN2003
Q6, 10, 11	15129175	DTC124XF
Q16-25	15129304	DTD114EF
Q13, 14	15129617	2SD1293M-R
Q27, 28, 31, 32, 35, 36, 39, 40, 43, 44	15129618	2SD1733R

— ELECTRICAL PARTS LIST —

Ref. No.	Parts No.	Description
DIODE		
D1-4, 17, 18 R57, R77	15019101	1S1555
D45	15019129	1S1885
D21	15019138	DAN201
D22	15019139	DAP201
D15, 16	15019144	1SS114
D23-44	15019209TO	S5500G
D5-14	15019265	ERB44-06
D19, 20	15019273	4B4B41LC1
SEMI-FIXED RESISTOR		
VR6, 11	13299133	RHAOCS338A 4.7kohm
VR9, 10	13299177	RHEOA-140XA 10 kohm
VR7, 8	13299193	EVN-D4AA00B54 50 kohm
VR5	13299199	EVN-D4AA00B13 1 kohm
VR1-4	13299203	EVN-D4AA00B25 200 kohm
VR12	13299578	EVM-K3GA00B52 500 ohm 1/2W
VR13	13299202	EVN-D4AA00B23 2 kohm (S/No.780450 and up)
RESISTOR ARRAY		
RA3	13919142	RGLD8-104J 100 kohm × 8
RA1, 2	13919311	RMLS8-223J 22 kohm × 8
RESISTOR		
	13819125	1 ohm 1/2W
	13819173	100 ohm 1/2W
	13819193	680 ohm 1/2W
	13819197	1 Kohm 1/2W
	13819203	1.8 Kohm 1/2W
	13829105	1.3 Kohm 1 W
R72	13829151M0	1 ohm 1 W
R40	13839145	82 ohm 3 W
	13839281	8.2 ohm 20 W
R54	13859111	0.47 ohm 1 W
CAPACITOR		
C29	13659247M0	3300 MF/63V
C55	13659215M0	4700 MF/25V
C11-20	13529114	470 pF/1KV

— ELECTRICAL PARTS LIST —

Ref. No.	Parts No.	Description
CONNECTOR		
CN203	13439266	MOLEX 5267-10A (10 pin)
CN207	13439278	MOLEX 5267-11A (11 pin)
CN200	13439293	MOLEX 5273-6A (6 pin)
CN204	23435294	MOLEX 5273-04A (4 pin)
CN205	13439295	FCN724P014-AU/L (14 pin)
CN201, 202	13439325	HLEM20S-1 (20 pin)
CN206, 209, 210	13439327	MOLEX 5267-02A (2 pin)
CN208	13439340	SLEM16S-2 (16 pin)
OTHERS		
L1, 2	12199550	Fuse clip H0446
T1	12449242	RC855-221K COIL 220 uH
RL1	12449252	Trans. EI-127-063
	12439218	Relay
	22465153	Heat sink
	22465495	Heat sink
	22465160	Heat sink (for Dide bridge)
FUSE		
F1	12559514	CEE2AT (2 ampere)
F2	12559516	CEE3.15AT (3.15 ampere)
	12559106	SGA-2A (2 ampere) for 100V
	12559302	MGC2A (2 ampere) for 117V
	12559513	CEE-1AT (1 ampere) for 220V, 240V

— EXPLODED VIEW —

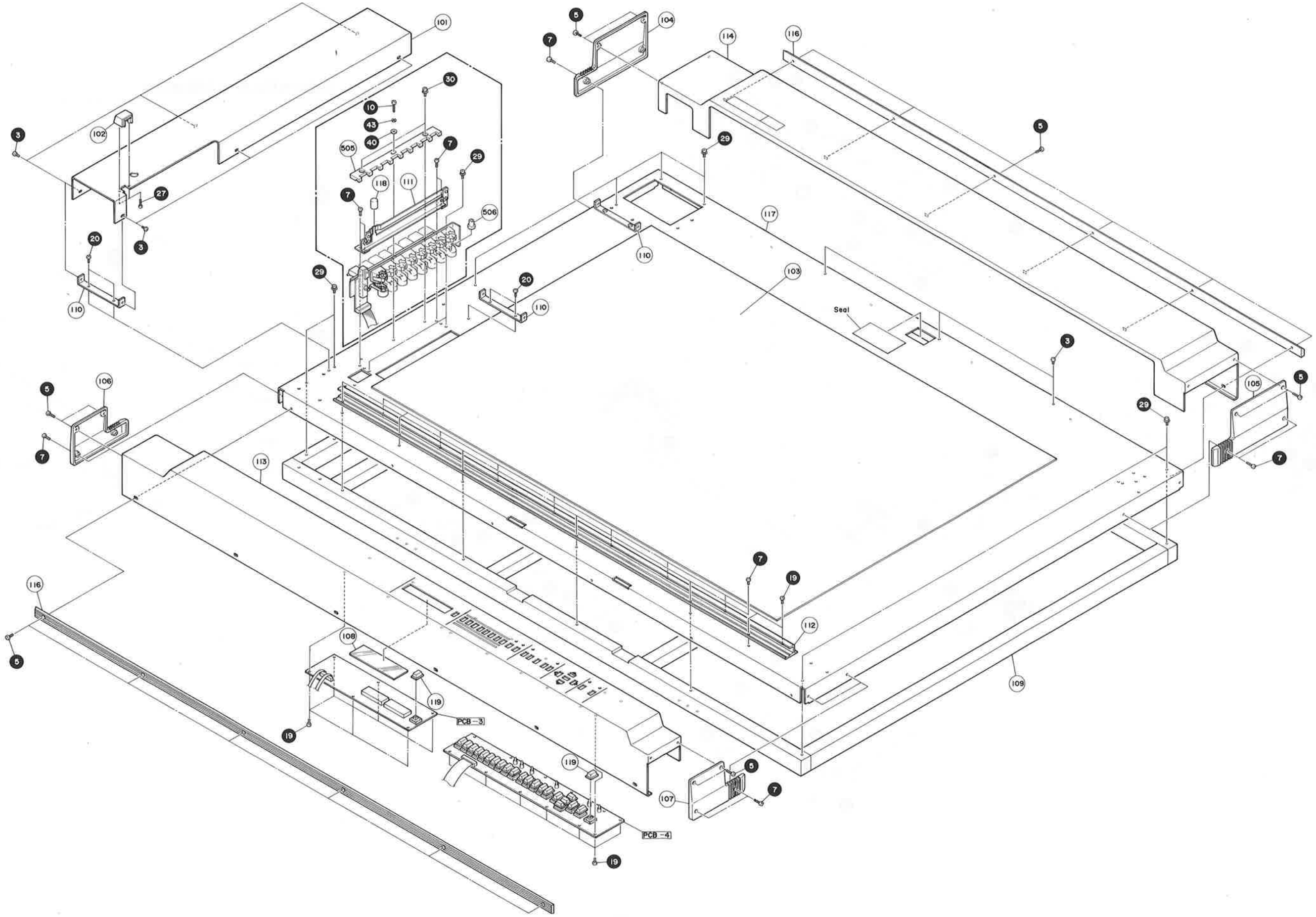

— EXPLODED VIEW —

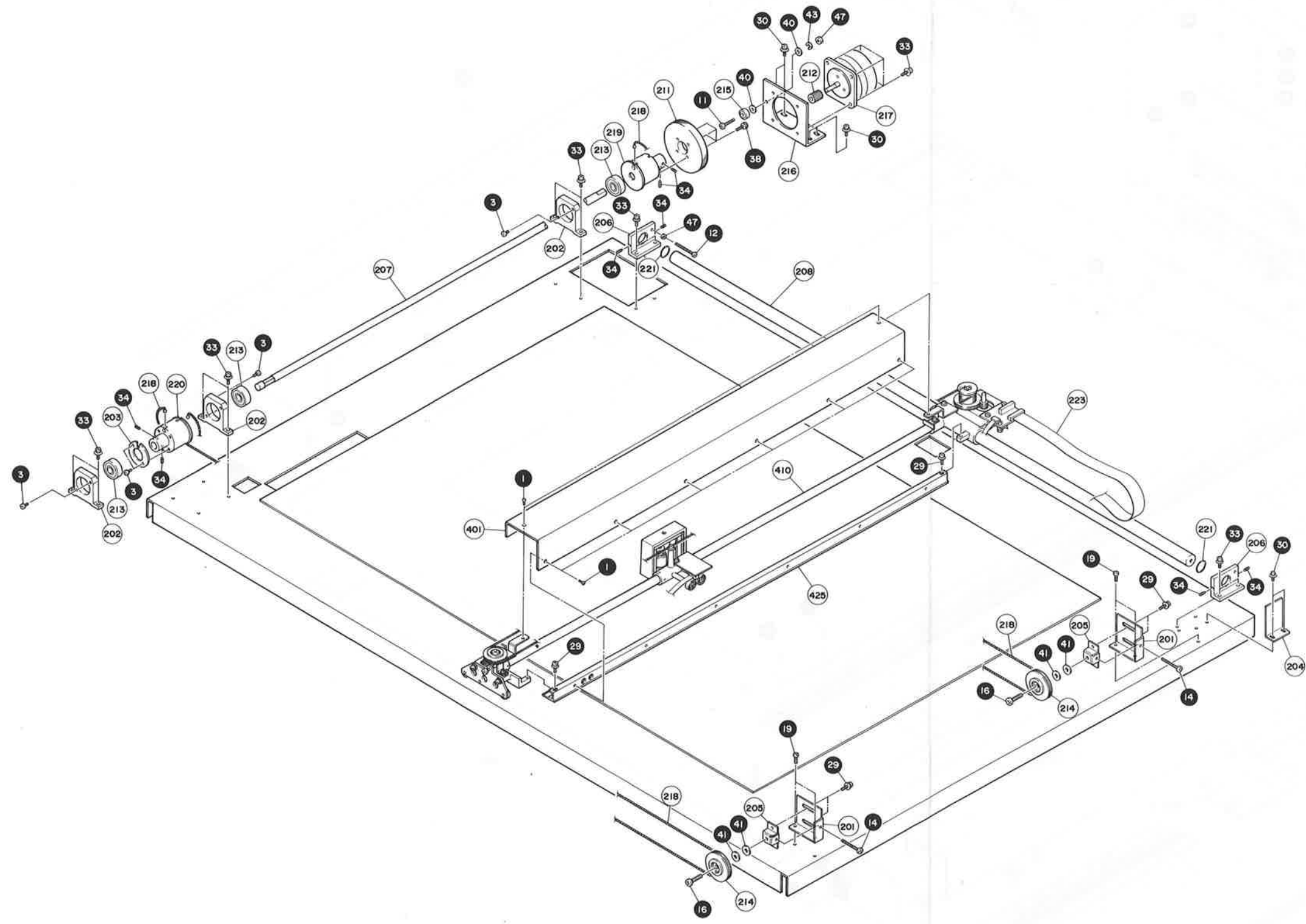

• PEN-STOCK ASSEMBLY

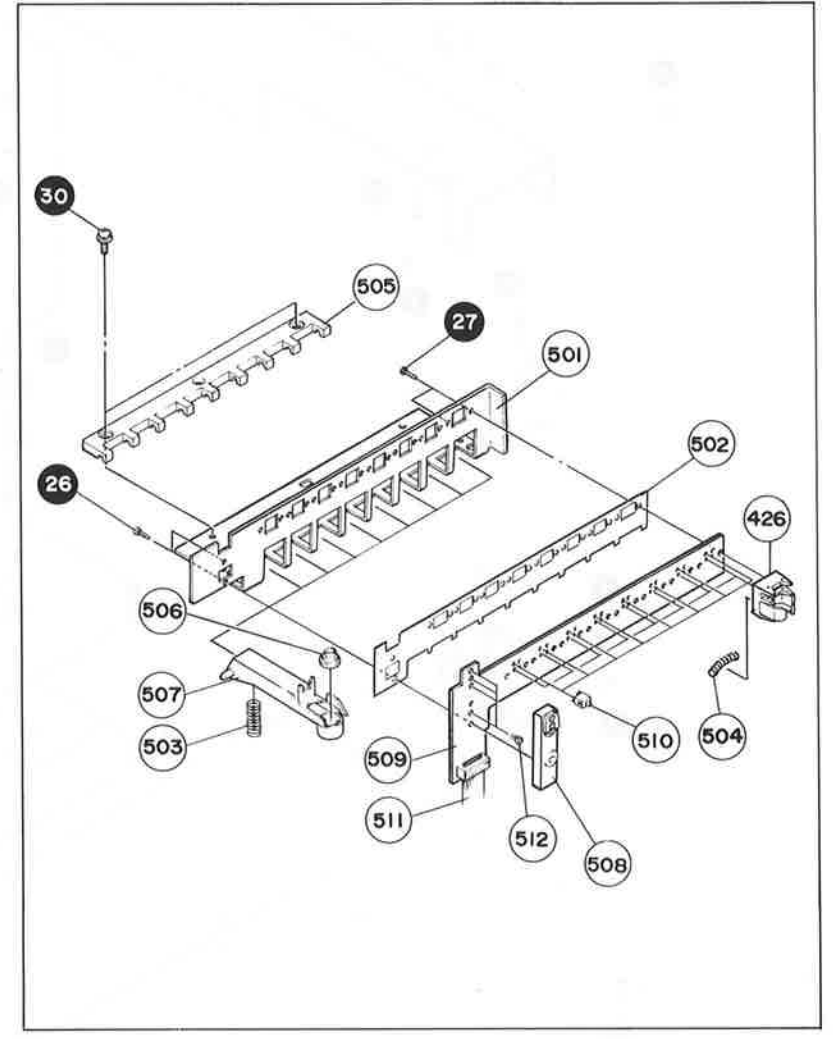

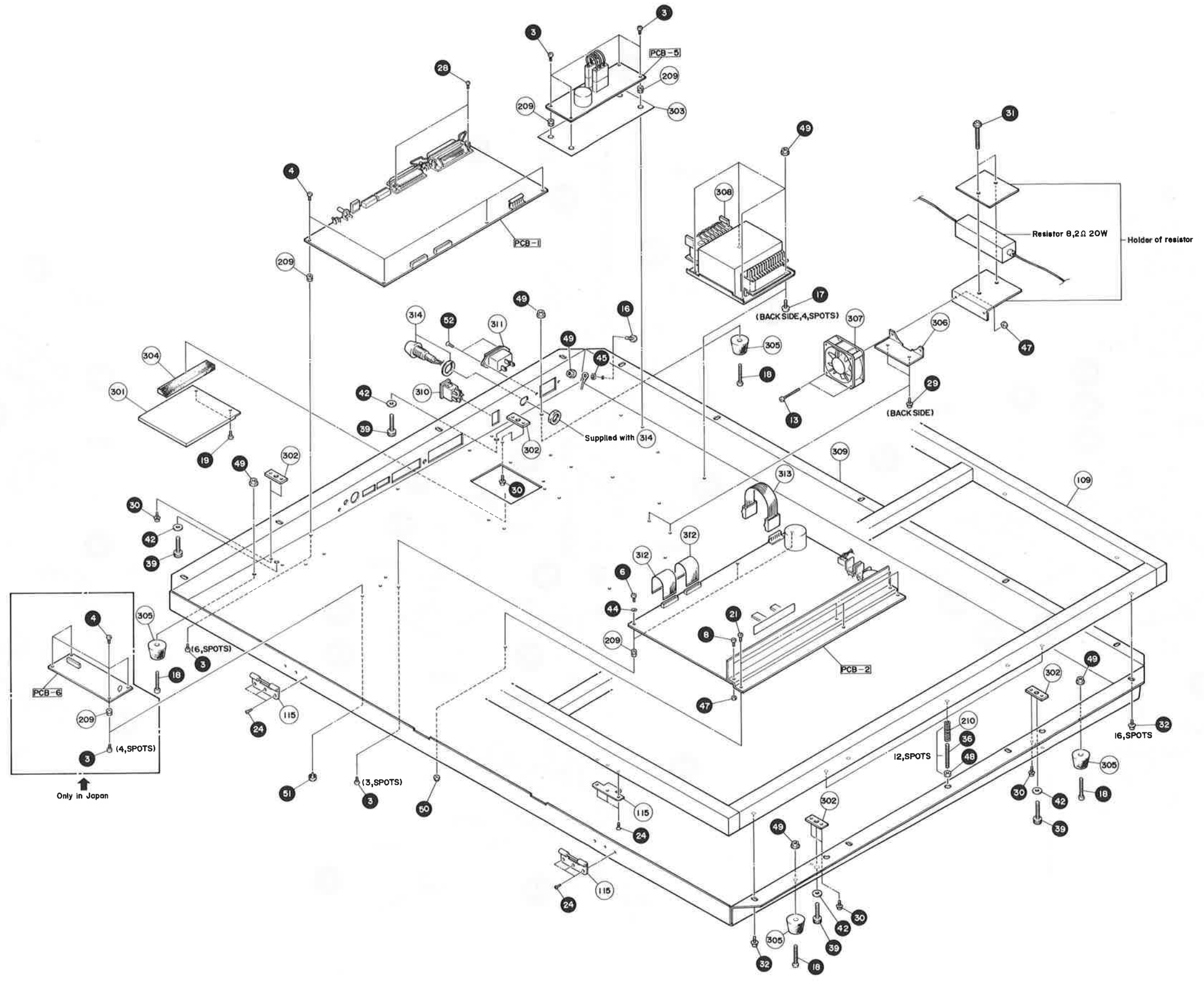

— EXPLODED VIEW —

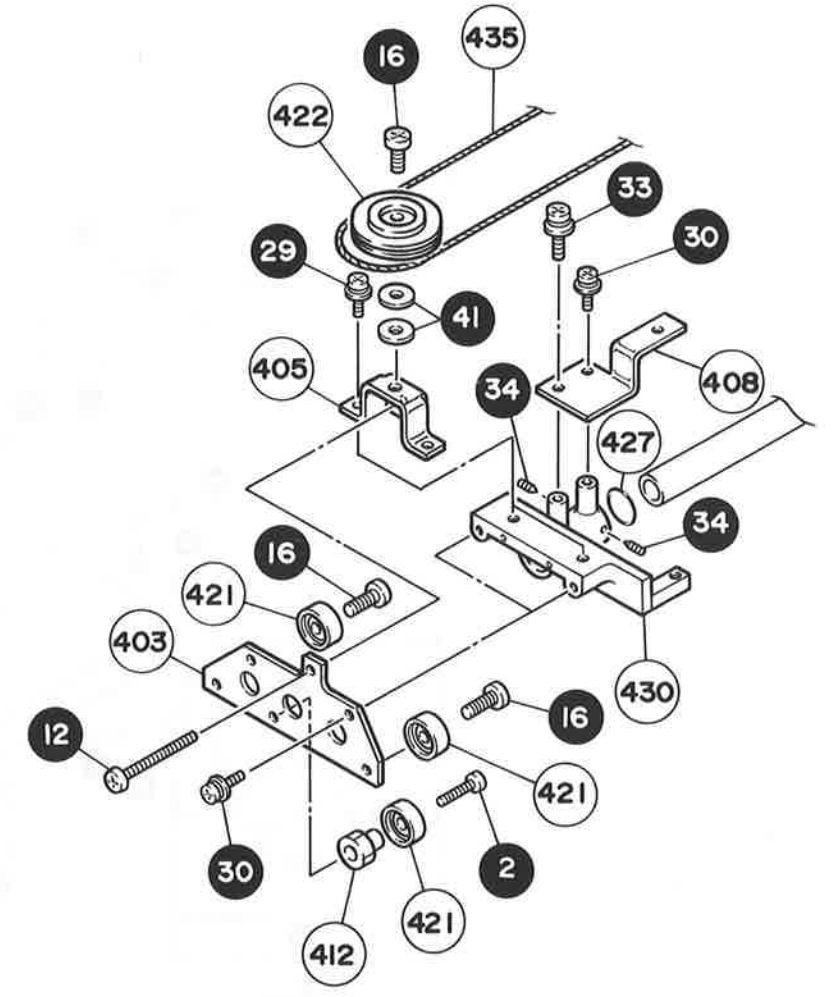
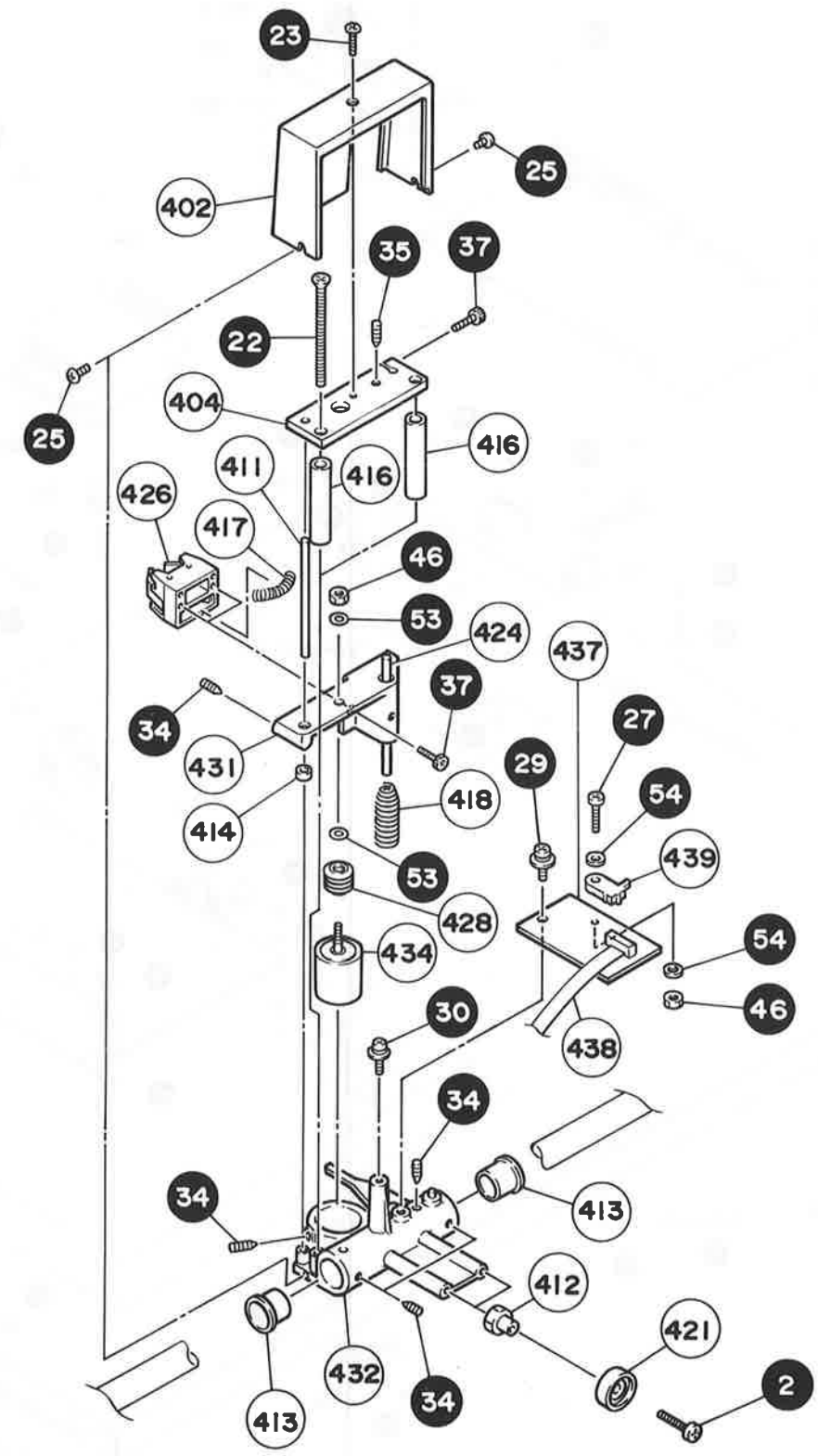
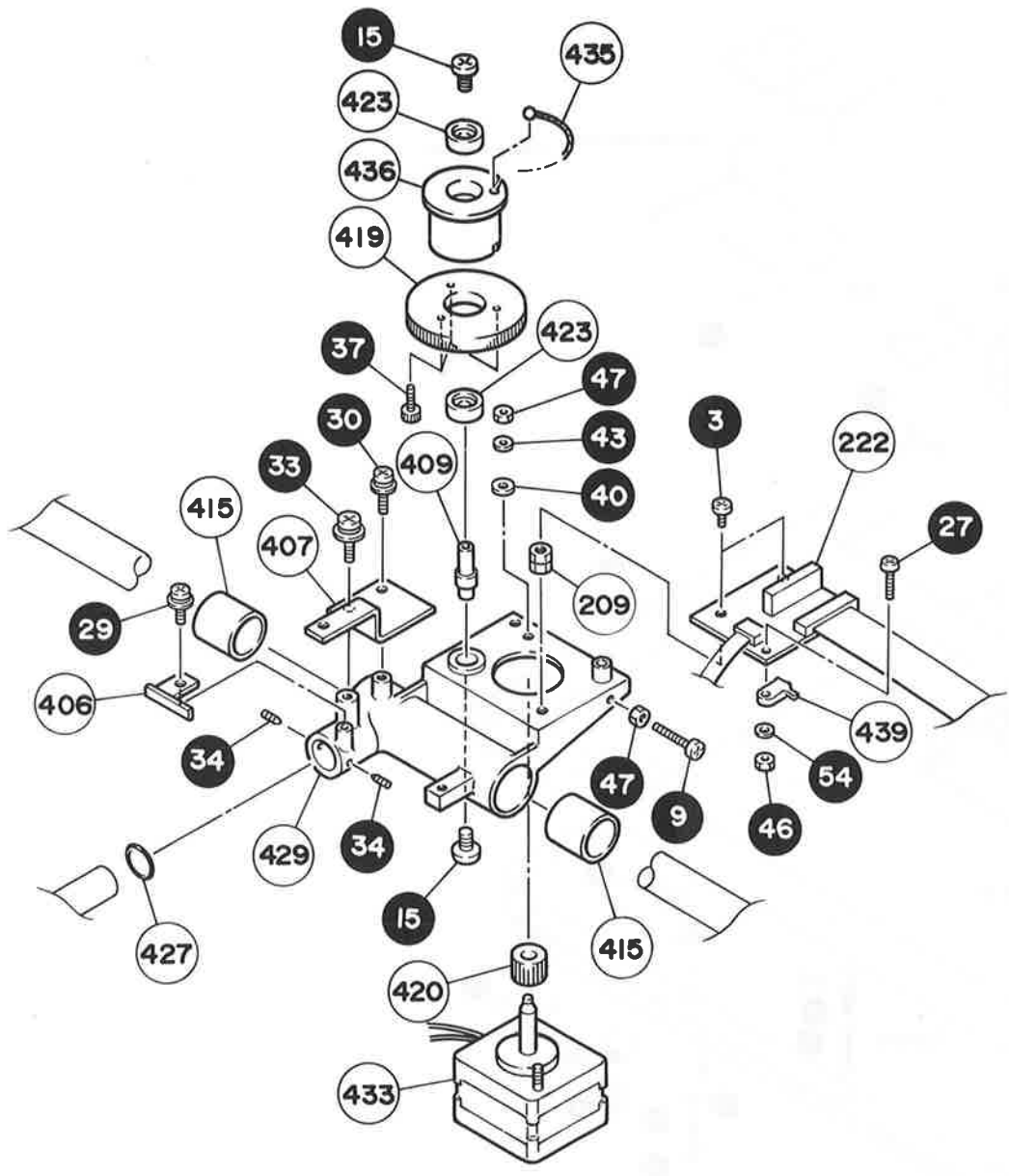

— MECHANICAL PARTS LIST —

Ref. No.	Parts No.	Description
101	22025316	Motor cover
102	22025713	Pen sensor cover
103	22025760	Electrostatic board
104	22025772	Side cover (BL)
105	22025773	Side cover (BR)
106	22025774	Side cover (FL)
107	22025775	Side cover (FR)
108	22025796	LED cover
109	22115517	Frame
110	22125704	Channel for installing Motor cover
111	22145225	Pen stock arm ass'y
112	22185339	X-rail
113	22215517	Front panel
114	22215518	Back panel
115	12329133	Hinge
116	22345303	Panel protector
117	22355364	Drawing table
118	12479187	Button (black)
119	22485116	Button
201	22035141	Pulley stand
202	22115102	Housing
203	22125223	Drum plate
204	22135334	Stopper No.2
205	22145113	Stay for pulley
206	22145115	Stay for guide bar
207	22145322	Drive shaft
208	22145826	X-axis guide bar
209	2215051200	Long nut (L = 6mm)
210	22175182	Spring
211	22175604	Main gear
212	22175605	X-motor gear
213	12179721	bearing 6000ZZ
214	12179723	Pulley with bearing
215	12179727	Bearing 623ZZA
216	22355365	Base for installing motor
217	22435121	X-axis motor
218	22565309	X-axis wire
219	22565331	X-pulley
220	22565338	X-pulley (F)
221	12669234	O ring P18
222	22925473	PCB for X-axis flat cable
223	23475202	Flat cable

— MECHANICAL PARTS LIST —

Ref. No.	Parts No.	Description
301	22025326	ROM cover
302	22195798	Holder for stand
303	22255129	Insulation seal
304	22265369	Cushion of ROM
305	12359110	Rubber foot
306	22355366	Base for installing fun
307	22435126	fun
308	2245542801	Power transformer
309	22815559	Chassis for controller
310	13149116	Power switch
311	13429708	AC inlet
312	13479208	Flat cable
313	23495549	Wiring (Main↔Power)
314	12199515	FUSE HOLDER FOR 100V, 220V, 240V
314	12199551	FUSE HOLDER FOR 117V
	12559106	Fuse SGA-2A (2 ampere) for 100V
	12559302	Fuse MGC2A (2 ampere) for 117V
	12559513	Fuse CEE-1AT (1 ampere) for 220V, 240V
	<u>7582711000</u>	<u>Y-rail Ass'y</u>
401	22025317	Y-rail cover
402	22025761	Pen carriage cover
403	22125218	Plate of Y-rail base
404	22125219	Pin plate
405	22125703	Channel installed wire
406	22135333	Stopper No.1
407	22145117	Stay of Y-rail cover (Back)
408	22145118	Stay of Y-rail cover (Front)
409	22145324	Shaft of Y-pulley
410	22145827	Y-axis guide bar
411	22145828	Parallel Pin
412	22155560	Bush of bearing
413	12159754	Oilless bush 80B-1620
414	12159755	Oilless bush 80B-0202
415	12159758	Oilless bush 80B-1820
416	22165127	Spacer
417	22175183	Spring of pen holder Ass'y
418	22175172	lifting spring
419	22175606	Y-drive gear
420	22175607	Y-motor gear
421	22175707	Bearing
422	12179724	Pulley with bearing
423	12179726	Bearing
424	22175728	Linear bearing
425	22185340	Y-rail

— MECHANICAL PARTS LIST —

Ref. No.	Parts No.	Description
426	22195805	Pen holder Ass'y
427	12269233	O ring P16
428	22265357	Air dumper
429	22355359	Y-rail base (Back)
430	22355360	Y-rail base (Front)
431	22355362	Pen holder base
432	22355363	Carriage base
433	22435122	Y-axis motor
434	22435307	Linear solenoid
435	22565310	Y-axis wire
436	22565328	Y-pulley
437	22925474	PCB for Y-axis flat cable
438	23475194	Flat cable
439	13169670	Limit SW SPPB12
	<u>7582721000</u>	<u>PENSTOCK ASSAMBLY</u>
501	22115516	Pen Stock Frame
502	22165324	Insulating Cover
503	22175169	Spring of Pen Cap Lever
504	22175170	Spring of Pen Holder Ass'y
505	22195780	Holder of Pen Cap Lever
506	22335310	Pen Cap (black)
507	22335311	Pen Cap Lever
508	22355345	Pen Sencer Base
509	2292520501	PCB
510	13129361	Switch SPPB-51
511	23495360	Wiring # 2
512	15229715	Photo Interrupter
PCB ASSEMBLY		
PCB-1	7582725000	MAIN BOARD
PCB-2	7582727000	POWER BOARD NO.2
PCB-3	7582723000	COUNTER BOARD
PCB-4	7582722000	PANEL BOARD
PCB-5	7581825000	POWER BOARD NO.1 (Same DPX-2000)
PCB-6	7582419100	KANJI ROM BOARD (ONLY IN JAPAN)
ACCESSORY		
	22025848	Dust cover
	22625627	Carton box
	22655107	Pad top
	22655108	Pad bottom
	22335314	Pen cap for ink pen (white)
	22335318	Pen cap for HP's pen (gray)
	12569250	Tweezers
AC CORD		
	13499108	VCTFK-3m for 100V
	13499107	VM-0033 for 117V
	13439817FO	EC-702-J05 for 220V
	13495110	BB6742-BB6791 for 240V (England)
	13439814FO	SC415-J06 for 240V (Australia)

— SCREWS AND NUTS LIST —

No.	DESCRIPTION	No.	DESCRIPTION
1	BINDING SCREW 2.6 × 4mm BC	28	PAN HEAD SCREW 3 × 8mm CM
2	BINDING SCREW 2.6 × 10mm BC	29	DOUBLE SEMS SCREW 3 × 6mm BC
3	BINDING SCREW 3 × 4mm BC	30	DOUBLE SEMS SCREW 3 × 8mm BC
4	BINDING SCREW 3 × 4mm CM	31	DOUBLE SEMS SCREW 3 × 20mm BC
5	BINDING SCREW 3 × 6mm BC	32	DOUBLE SEMS SCREW 4 × 8mm BC
6	BINDING SCREW 3 × 6mm CM	33	DOUBLE SEMS SCREW 4 × 10mm BC
7	BINDING SCREW 3 × 8mm BC	34	DOUBLE POINT SET SCREW 3 × 3mm CM
8	BINDING SCREW 3 × 8mm CM	35	FLAT POINT SET SCREW 3 × 8mm BC
9	BINDING SCREW 3 × 10mm BC	36	FLAT POINT SET SCREW 4 × 30mm BC
10	BINDING SCREW 3 × 12mm BC	37	HEXAGONAL CAP SCREW 2 × 6mm BC
11	BINDING SCREW 3 × 15mm BC	38	HEXAGONAL CAP SCREW 3 × 8mm BC
12	BINDING SCREW 3 × 25mm BC	39	HEXAGONAL CAP BOLT 6 × 20mm Ni
13	BINDING SCREW 3 × 35mm BC	40	FLAT WASHER 3 × 8 × 0.5mm CM
14	BINDING SCREW 3 × 40mm BC	41	FLAT WASHER 4 × 10 × 0.8mm CM
15	BINDING SCREW 4 × 6mm BC	42	FLAT WASHER 6 × 13 × 1 Ni
16	BINDING SCREW 4 × 8mm BC	43	SPRING WASHER M3
17	BINDING SCREW 4 × 10mm BC	44	TEETH WASHER M3 CM
18	BINDING SCREW 4 × 25mm BC	45	TEETH WASHER M4 CM
19	BIND TAPPING SCREW 3 × 6mm B1 BC	46	HEXAGONAL NUT M2
20	BIND TAPPING SCREW 3 × 6mm B1 CM	47	HEXAGONAL NUT M3
21	BIND TAPPING SCREW 3 × 6mm C1 CM	48	HEXAGONAL NUT M4
22	FLAT HEAD SCREW 3 × 35mm BC	49	NUT with S.P.W M4 CM
23	OVAL HEAD SCREW 2 × 8mm BC	50	CAP NUT M3 BC
24	OVAL HEAD SCREW 3 × 8mm BC	51	NYLON RIVET
25	TRUSS HEAD SCREW 2 × 4mm BC	52	BIND TAPPING SCREW 3 × 8mm C1 BC
26	TRUSS HEAD SCREW 2 × 6mm BC	53	RUBBER WASHER
27	PAN HEAD SCREW 2 × 8mm BC	54	SPRING WASHER M2

— CHECK AND ADJUSTMENT PROCEDURES —

1. ROM position:

EP ROMS

- A : Font 27C256 (256KB)
- B : Main 27512 (512KB)
- C : I/O 2764 (64KB)
- D : TRP 27512 (512KB)

see fig. 1-1.

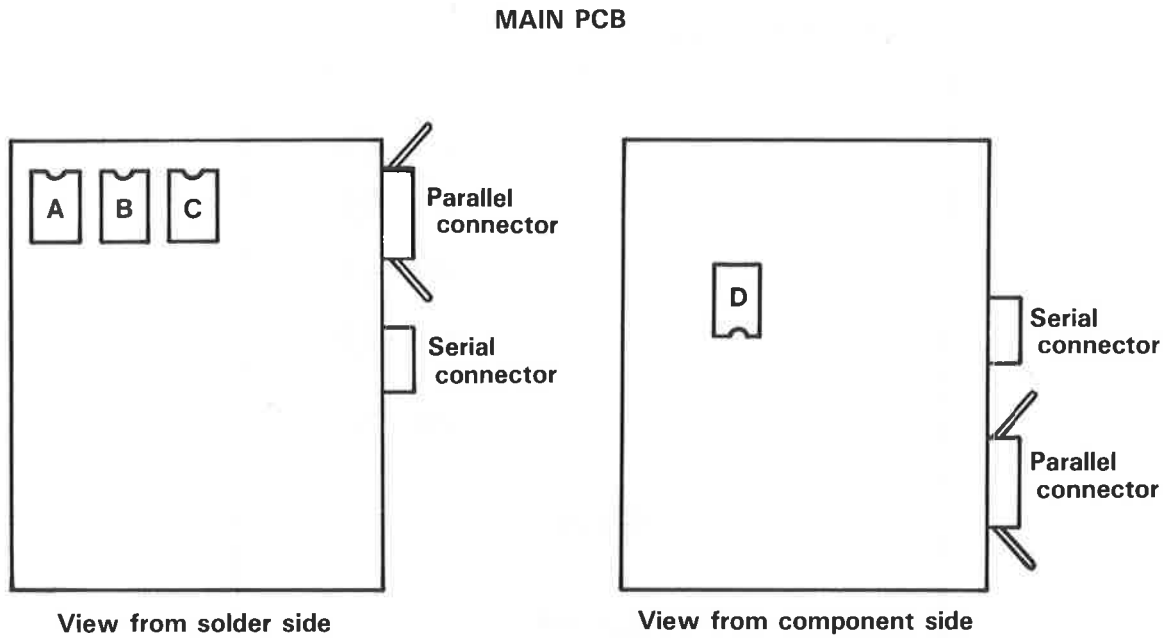

fig. 1-1

2. Check voltage of source:

Check voltage of each terminal of CN200 on Power Board 2 and cement resistor. (see fig. 2-1)

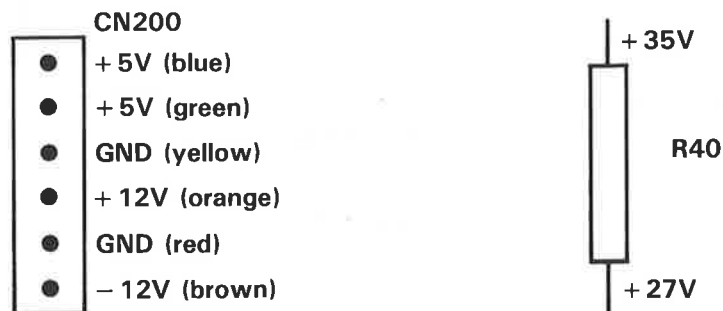

fig. 2-1

— CHECK AND ADJUSTMENT PROCEDURES —

3. Set up initialize of potentiometer:

Set up by turning potentiometers as shown in fig. 3-1, if you need adjustment it before power on.

PEN FORCE: Center

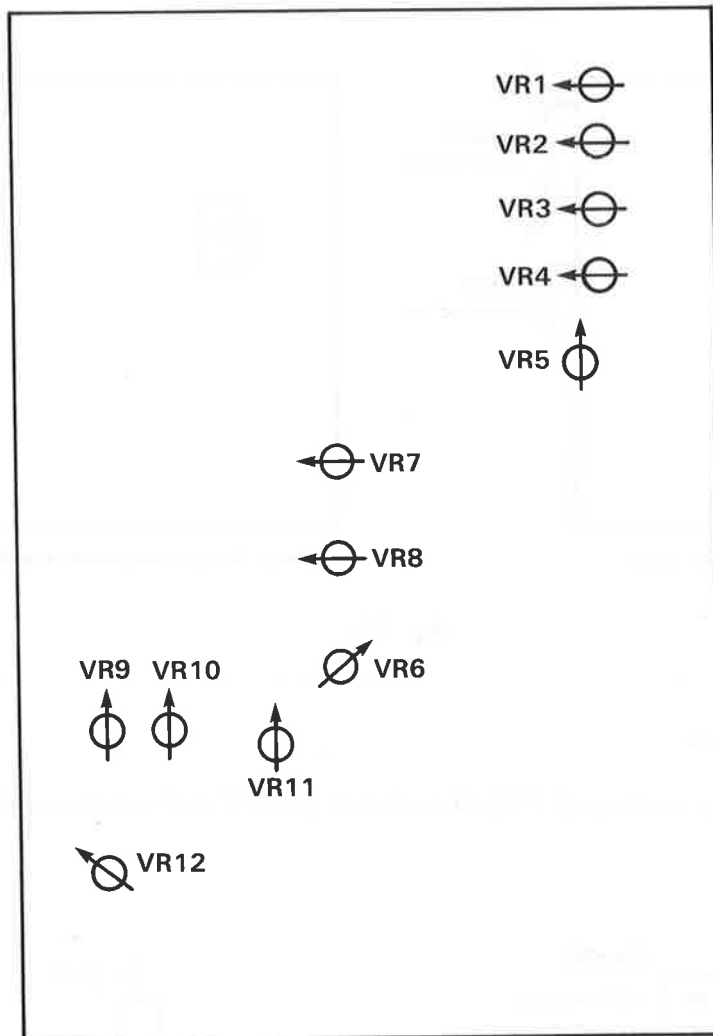

POWER BOARD 2

fig. 3-1

— CHECK AND ADJUSTMENT PROCEDURES —

4. Adjust motor torque and pen pressure:

Adjust potentiometer (VR8, VR6, VR9, VR7, VR11, VR10, VR12, VR5) so that pulse or wave width becomes normal value. (see fig. 4-1)

Adjustment of potentiometer

	VR No.	CHECK POINT	WAVE FORMS	OPERATION
X A X I S	VR8 ONE SHOT TIME	Anode of diode at R57		Press right or left position key (Adjust pulse width)
	VR6 POWER	Same as above		Same as above (Adjust height level)
	VR9 HOLDING TORQUE	Anode at D43		Motor not rotate (Adjust wave width)
Y A X I S	VR7 ONE SHOT TIME	Anode of diode at R77		Press up or down position key (Adjust pulse width)
	VR11 POWER	Same as above		Same as above (Adjust height level)
	VR10 HOLDING TORQUE	Anode at D44		Motor not rotate (Adjust wave width)
S O L E N O I D	VR12	Anode at D45	DC 30V	Power on (Adjust DC level)
	VR5	11th pin of IC16	DC 0.55V	Pen goes up (Adjust DC level)

fig. 4-1

— CHECK AND ADJUSTMENT PROCEDURES —

5. Height of pen:

Note: Make adjustment in Item 2). and 3). at the power switch "ON".

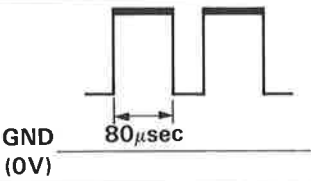
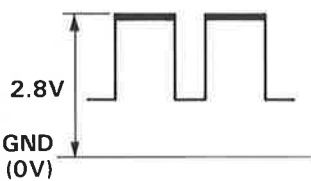
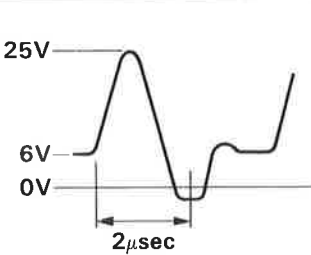
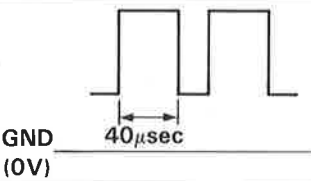
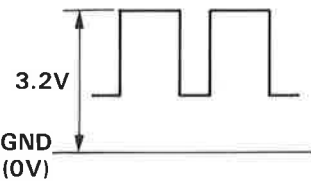
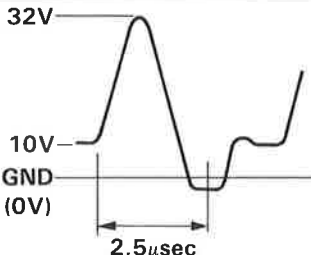
- 1). Set up pens at No.1 and No.8 pen clip of pen stock, and dummy pen at pen carriage.
- 2). Adjust the flange of pen of pen stock and pen carriage to the same level by turning the screw (REF. 35) and set correct position. (see fig. 5-1)
- 3). Turn twelve nuts so that clearance between pen tip and drawing table becomes 2 millimeters. (see fig. 5-2)
- 4). Put Paint Lock on screw after adjustment.

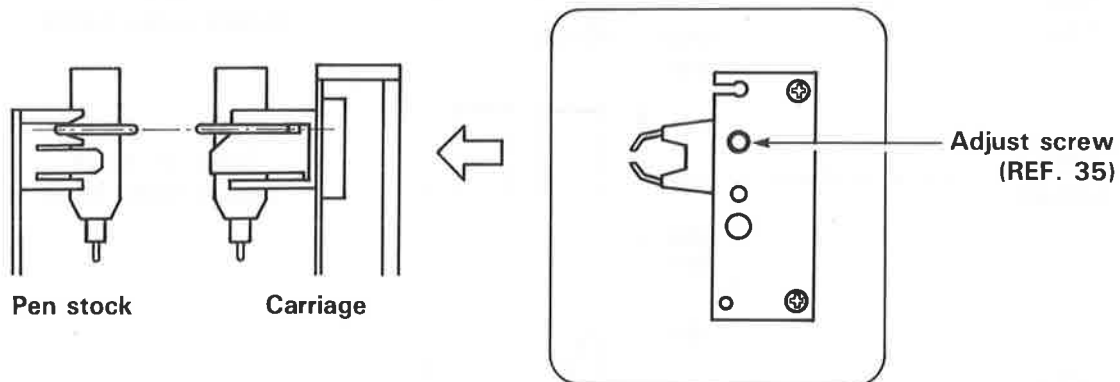
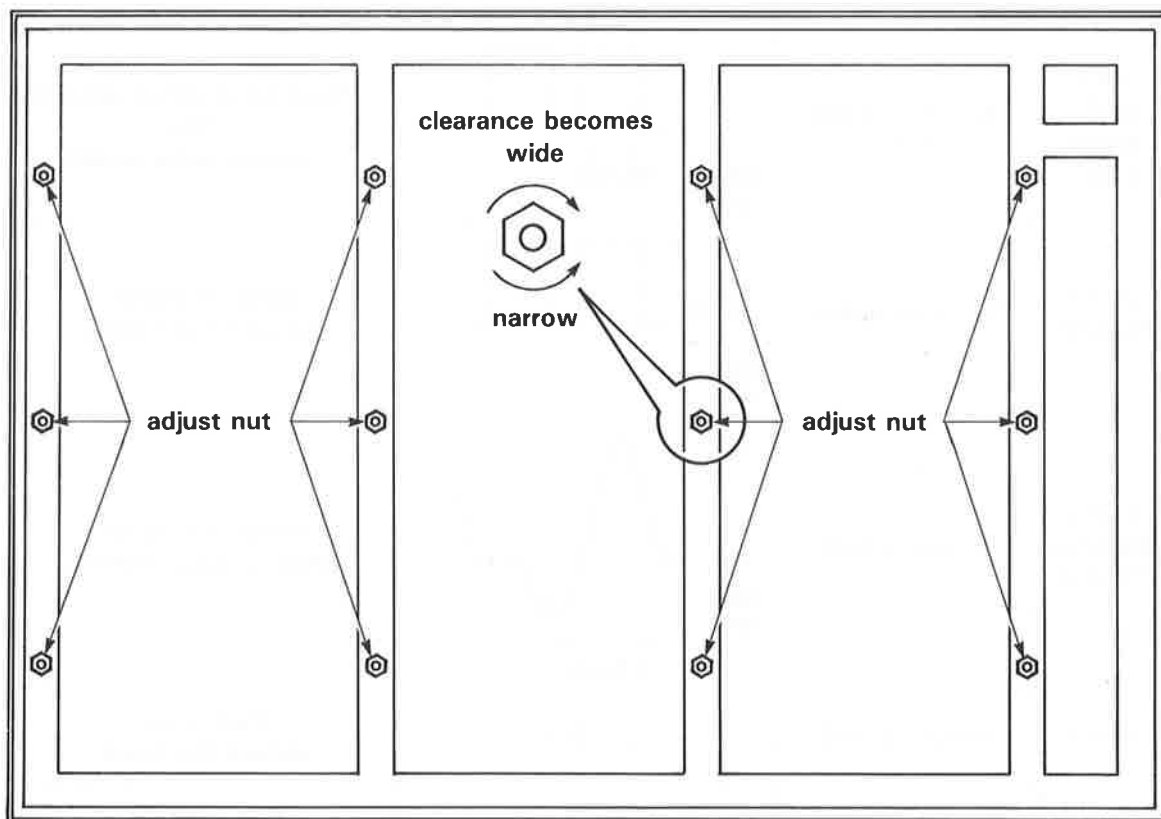

fig. 5-1



view from bottom side of drawing table

fig. 5-2

— CHECK AND ADJUSTMENT PROCEDURES —

6. Adjustment of pen stock position:

- 1). Turn power off.
- 2). Set all white nib of DIP SW. 1 and 2 in the ON position, and Baud Rate SW in position 15.
- 3). Move pen carriage to LL position by hand.
- 4). Turn power on pressing "RIGHT POSITION (→)" key.
- 5). Press "ENTER" key. Next, "LL" key.
- 6). Pen carriage moves to pen stock according to the number of key you press.
- 7). Loosen three screws. Adjust the position of pen stock by sliding parallel to Y-rail as shown in figure 6-1.
- 8). Tighten three screws.
- 9). Turn power off.
- 10). Move pen carriage to LL position by hand.
- 11). Check that the flange of pen doesn't touch with sensor. (see fig. 6-2)
- 12). If flange touches with it, loosen three screws and slide pen stock a little distance to the left side.

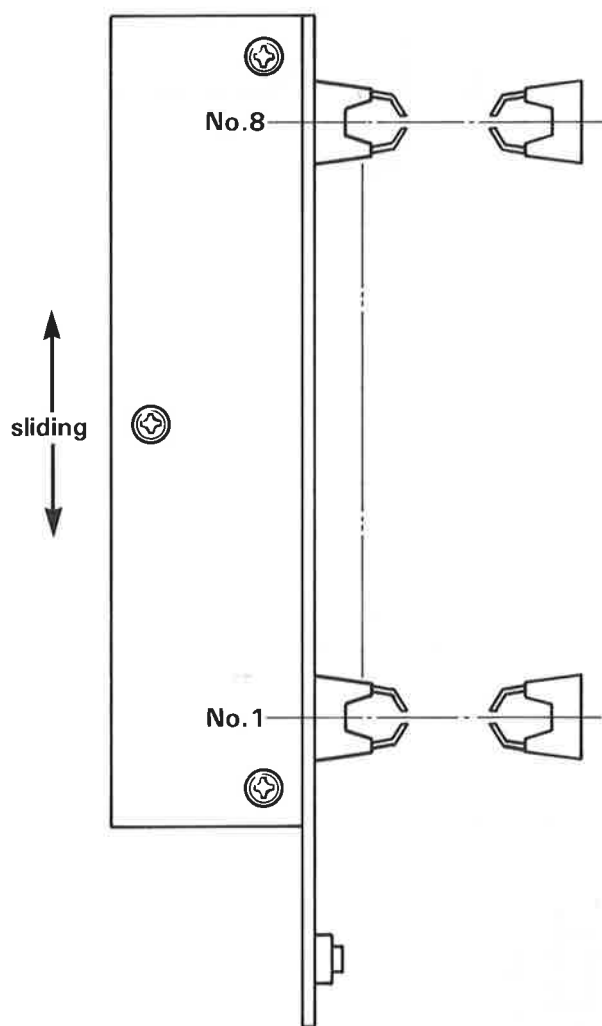

fig. 6-1

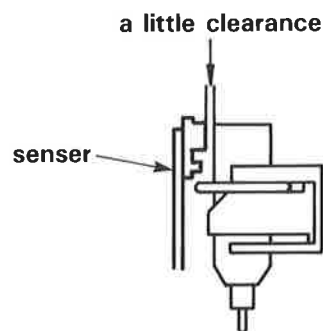

fig. 6-2

— CHECK AND ADJUSTMENT PROCEDURES —

7. Adjust the sensitivity of pen sensor:

Adjust potentiometer (VR1, VR2, VR3, VR4) so that peak of wave becomes 3.5V peak to peak (see fig. 7-1) when set up gray pen (Water Based Fiber Tipped Pen) at pen clip of pen carriage and move pen carriage to LL position.

VR No.	CHECK POINT	WAVE FORM
VR1	TP19	
VR2	TP20	
VR3	TP21	
VR4	TP22	

fig. 7-1

8. Adjustment of bushing:

Insert unit of plate of Y-rail base (REF. 403) into X-rail (REF. 122). Turn the bushing (REF. 412) by wrench so that it moves smoothly and have no play, upper bearing just touch with X-rail. (see fig. 8-1)

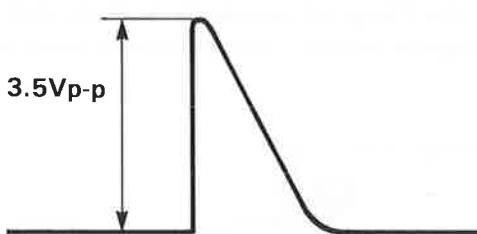
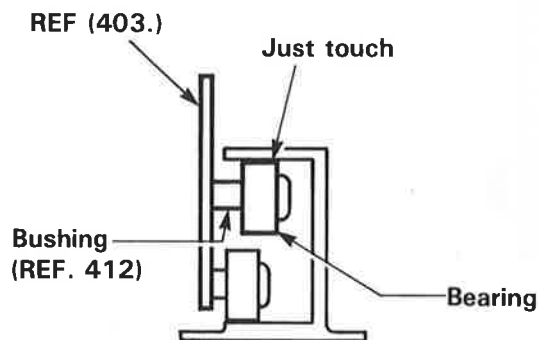

fig. 8-1

— CHECK AND ADJUSTMENT PROCEDURES —

9. Fit Y-axis guide bar into Y-rail base (Front):

Fit Y-axis guide bar (REF. 410) into Y-rail base (front) (REF. 430) so that clearance between X-rail (REF. 122) and head of screw (REF. 16) becomes about 1 millimeter. (see fig. 9-1)

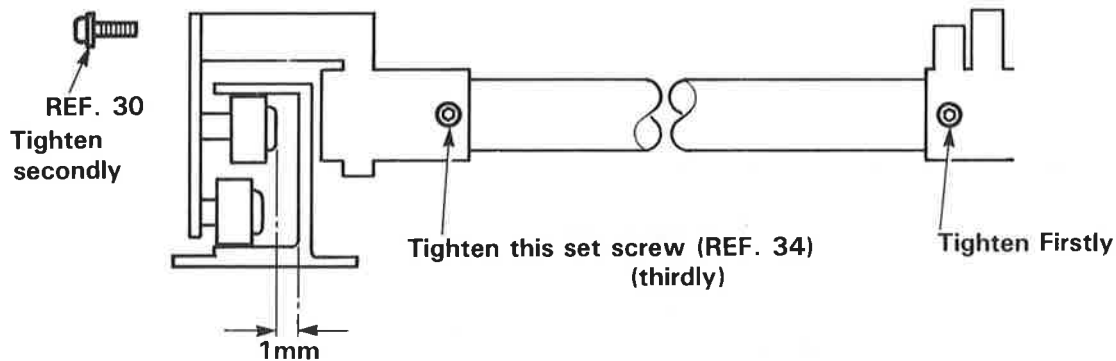

fig. 9-1

10. Pen carriage:

Turn the four set screws (REF. 34) so that pen carriage moves smoothly and no play and no looseness. Turn the two bushings (REF. 412) by wrench so that pen carriage moves smoothly and don't roll from side to side, bearings just touch with Y-axis rail. (see fig. 10-1)

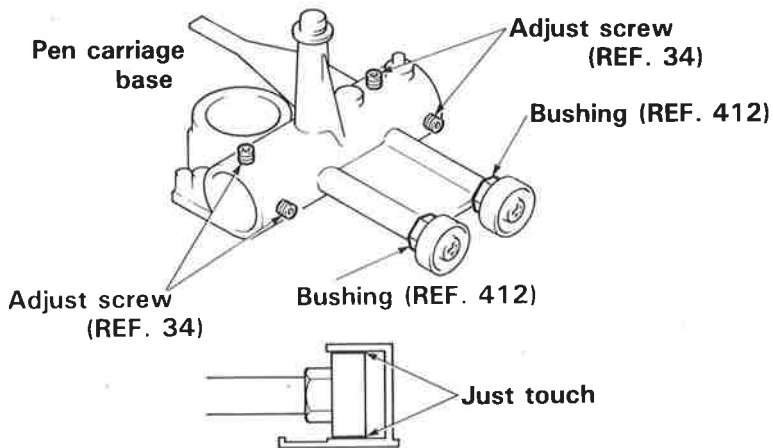
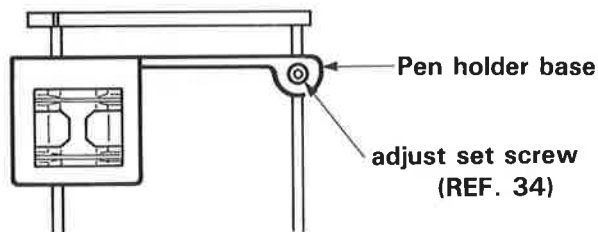

fig. 10-1

Turn a set screw so that Pen holder base moves smoothly and no play and no looseness.



— CHECK AND ADJUSTMENT PROCEDURES —

11. How to set the wire:

X-axis: Wind 12 turns in case of DPX-3300, 10 turns in case of DPX-2200. (see fig. 11-1)
 Y-axis: Wind 11 turns in case of DPX-3300, 9 turns in case of DPX-2200. (see fig. 11-2)

X-axis:
 After winding wire, put Y-arm to the left end.
 Then tighten the screws so that one turn of wire is left.

Y-axis:
 After winding wire, put pen carriage to the upper side.
 Then tighten a screw so that one turn of wire is left.

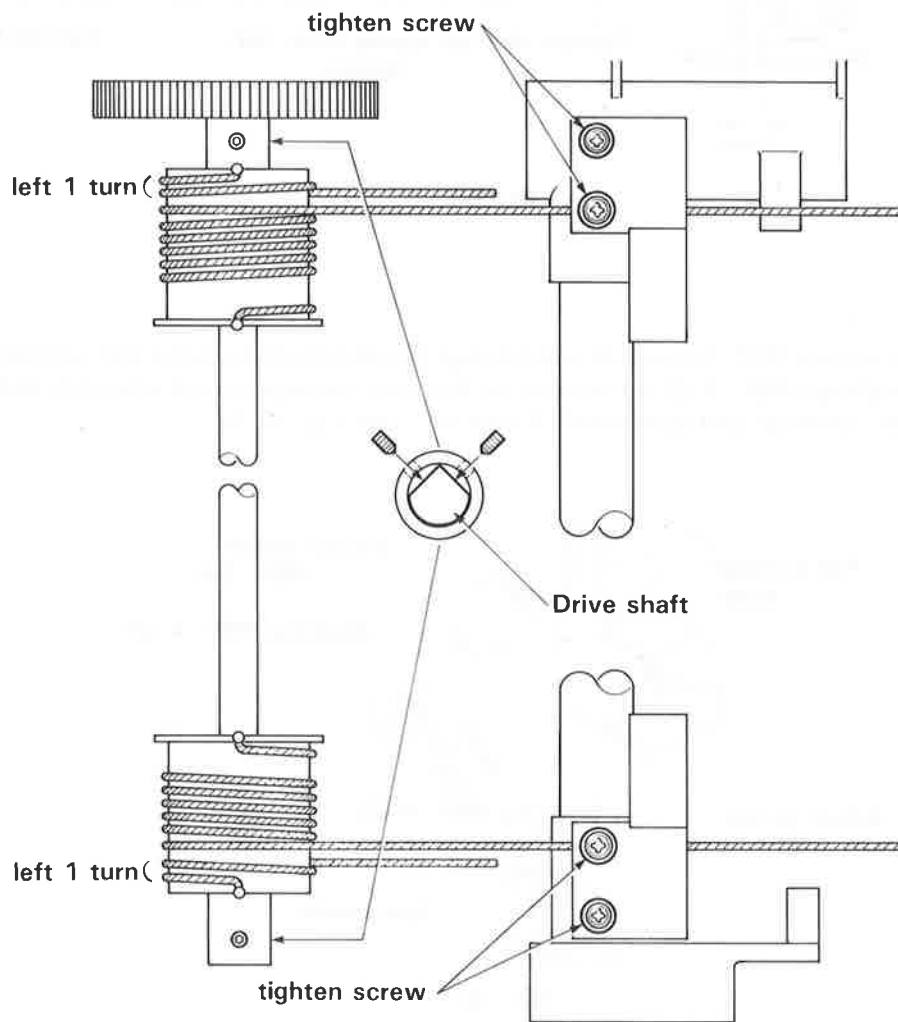

fig. 11-1

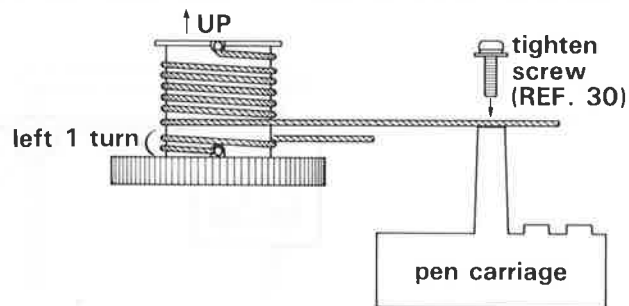

fig. 11-2

	DPX-3300	DPX-2200
X-axis	12 turns	10 turns
Y-axis	11 turns	9 turns

— CHECK AND ADJUSTMENT PROCEDURES —

12. Adjustment of tension:

Make free condition of wire's movement. (Take away two stay (REF. 407, 408) from Y-rail base and screw (REF. 30) from Pen carriage base (REF. 432).)

X-axis: (NOTE: When this adjustment, must install Base of installing motor (REF. 216) with bearing (REF. 215) which inserted X-pulley (REF. 219).)

- 1). Hang tension gauge in the middle of upper wire.
- 2). When pull the gauge up by 25 millimeter, an adequate tension is about 800 grammes in case of DPX-3300, 1100 grammes in case of DPX-2200. (see fig. 12-1)

Y-axis:

- 1). Hang tension gauge in the middle of wire.
- 2). When pull the gauge horizontally and softly till either wires to touch the other, an adequate tension is about 400 grammes in case of DPX-3300, 800 grammes in case of DPX-2200. (see fig. 12-2)

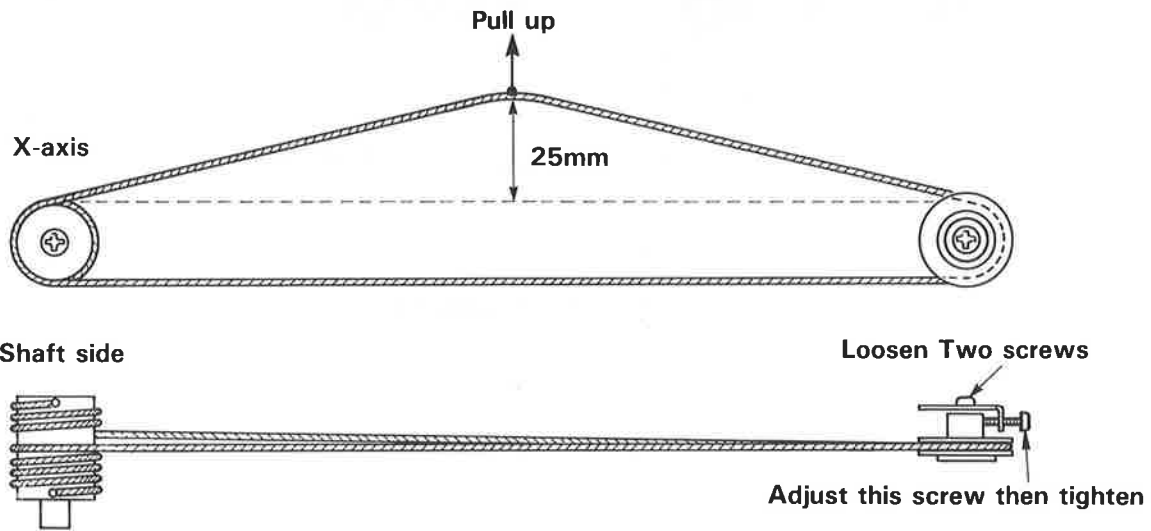

fig. 12-1

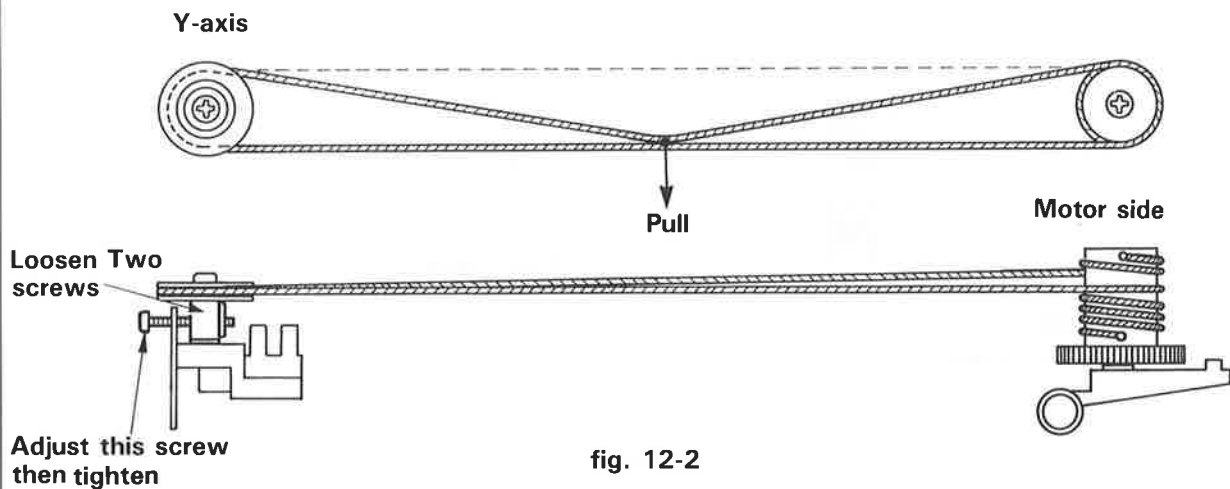

fig. 12-2

	DPX-3300	DPX-2200
X-axis	800 g	1100 g
Y-axis	400 g	800 g

— CHECK AND ADJUSTMENT PROCEDURES —

13. Y-arm square to X-axis:

Adjust by using right angle gauge (Special tool) so that angle of Y-arm as against X-axis guide bar becomes 90 degree. (see fig. 13-1)

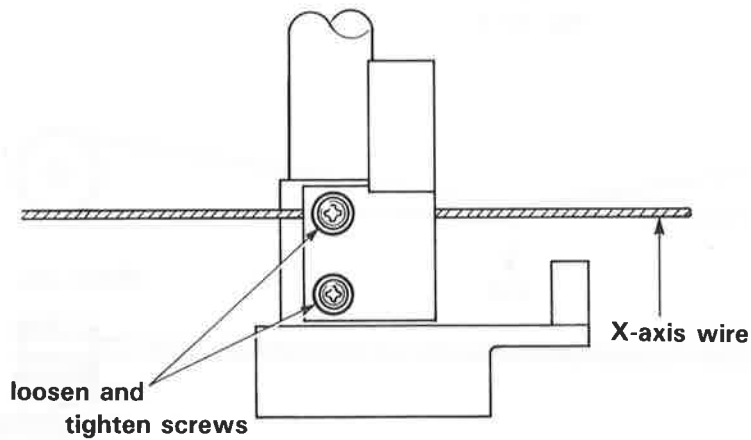
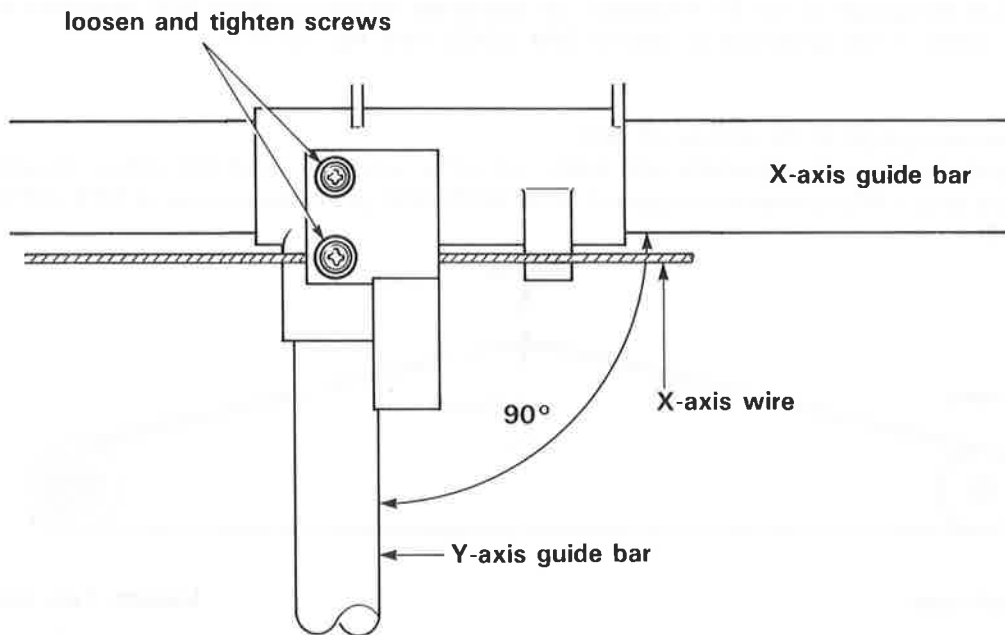

fig. 13-1

— CHECK AND ADJUSTMENT PROCEDURES —

14. Adjustment of gear:

Turn the screw (REF. 12) so that gears rotate smoothly. But, if there is no gap between each gear, not rotate. And if there is a large gap, there is difference between start point and end point when drawing circle. (see fig. 14-1)

Y-axis gear:

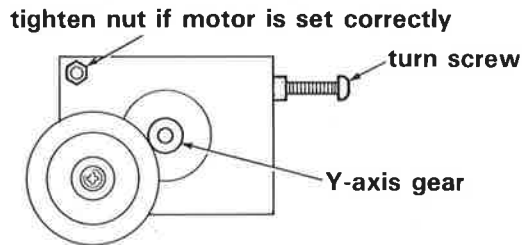

X-axis:

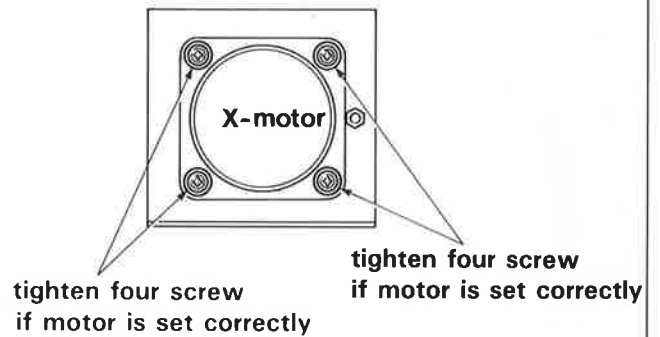
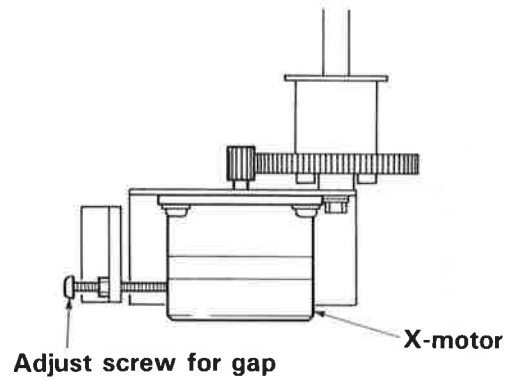
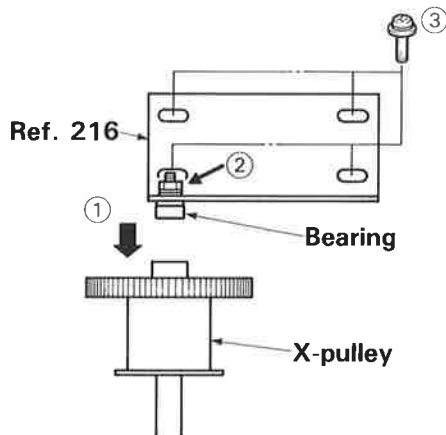

Fig. 14-1



- ① Put Base for installing motor (Ref. No. 216) so that Bearing is set in the center of hole of X-pulley.
- ② Tighten the nut.
- ③ Tighten the screws.

— MOVING FORCE CHECK —

Measure the moving force in X-axis and Y-axis by using tension gauge when DPX-3300 is power off.

Moving force in X-axis should be less than 700g. (approx.)

Moving force in Y-axis should be less than 200g. (approx.)

If these measured values are over, try adjustment procedure item No. 8, 10, 12, 14

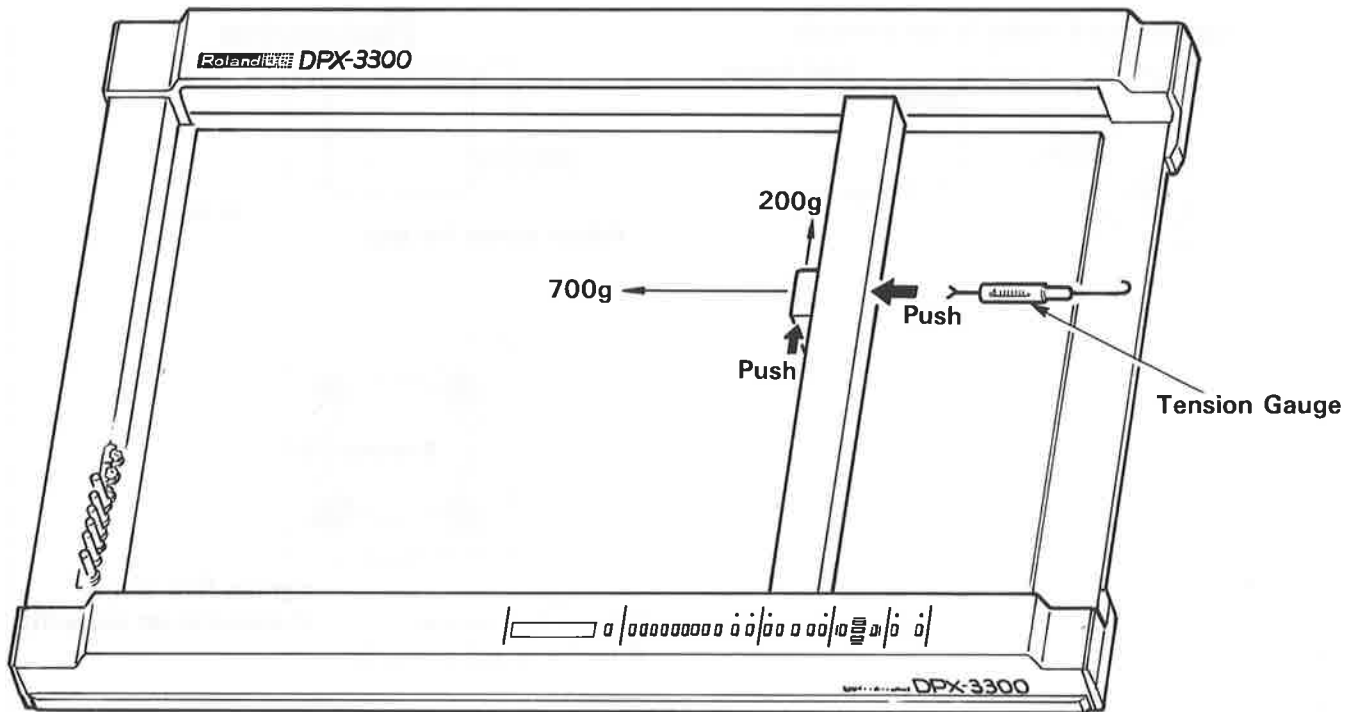

— CHECK MODE —

DPX-3300 has the "CHECK MODE" which is a test program with a built-in the EPROMs for service engineers. You can try a simple test without the host computer.

[SETTING]

Disconnect both X and Y motor wires before power on. (Connector No. CN207 and CN208 on Power Supply Board 2.)

Set all Dip Switches in position "ON" and Rotary Switch in position "15".

Set Pen Carriage to LL (lower left) position by hand.



[OPERATION]

Press "Right Cursor Key (→)" while turn the power on.

Press "Enter Key" and next select check mode by pressing relevant Pen Select number switch of following.

- No.1 Panel key checking
- No.2 Pen stock switches reading
- No.3 Pen sensor check
- No.4 Limit switches check
- No.5 Dip switch 1 reading
- No.6 Dip switch 2 reading
- No.7 Rotary switch (Baud rate switch) reading
- No.8 Maximum speed check
- LL Pen stock adjustment.

"ENTER" key + pen select number of following table.

PEN SELECT NUMBER	CHECK ITEM	DISPLAY & MOTION
1	Panel key checking	<div style="text-align: center;"> <p>X-axis Y-axis</p>  <p>No.1 2 3 4 5 6 7 8</p> </div> <p>A place of coordinate display corresponding to key number indicates "1" when pressed pen select switches.</p>
2	Pen stock switches reading	<div style="text-align: center;"> <p>X-axis Y-axis</p>  <p>No.1 2 3 4 5 6 7 8</p> </div> <p>If there is a pen in some pen holder at penstock, coordinate display indicates "1", if not "0".</p>
3	Pen sensor check	<div style="text-align: center;"> <p>X-axis Y-axis</p>  <p>Upper Lower Middle</p> </div> <p>Set the pen at pen carriage and move pen carriage to LL position by hand, and checking. If sensor reads marker, Coordinate Display indicates "1". (silver = 1, black = 0) If not sensing or always sensing, readjust the potentiometer VR1-VR4. (Adjust sensing level by using of gray pen.)</p>
4	Limit switches check	<p>When X-direction limit switch is turned on, PEN DOWN LED lights. When Y-direction limit switch is turned on, ERROR LED is lights.</p>

— CHECK MODE —

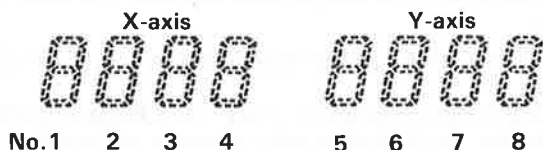
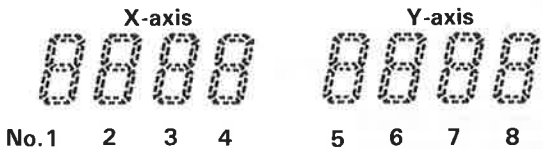
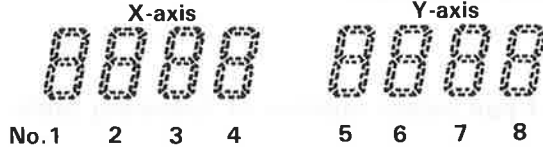
PEN SELECT NUMBER	CHECK ITEM	DISPLAY & MOTION
5	Dip switch 1 reading	<div style="text-align: center;"> <p>X-axis Y-axis</p>  </div> <p>Dip switch 1 setting is indicated on Coordinate display. ON is "1", OFF is "0".</p>
6	Dip switch 2 reading	<div style="text-align: center;"> <p>X-axis Y-axis</p>  </div> <p>Dip switch 2 setting is indicated on Coordinate display. ON is "1", OFF is "0".</p>
7	Rotary switch (Baud rate switch) reading	<div style="text-align: center;"> <p>X-axis Y-axis</p>  </div> <p>Set Rotary switch is position "0" and next press Coordinate's reset key after display of Coordinate stops some value. Turn the Rotary switch in some position, status of Rotary switch (decimal value) is indicated on Coordinate display.</p>

KEY NUMBER	CHECK ITEM	OPERATION
8	Maximum speed moving check	<p>Turn the power off, and reconnect X & Y motor wires. Press "Right Cursor Key (→)" while turn the power on. Press "Enter Key" and next Pen select No.8 key and next keep pressing relevant Pen Select number switch of following.</p> <p style="margin-left: 40px;"> X-direction : key 1 Y-direction : key 2 diagonal : key 3 stop : key 4-8 </p>
LL	Pen stock adjustment	<p>When press "ENTER" key + "LL" key + pen select number, pen carriage moves relevant stock position of key pressed. Then, try to adjust the pen stock position. (See page 71)</p>