

Service Manual for G-Carriage

brother

MODEL KG-88/89

INDEX

1. Features	1
2. Specifications	1
General comparison between KG-88 & 89	2
3. Table for trouble shooting	3
4. Disassembling the G carriage	6
5. Assembling the G carriage	14
6. How to adjust the G carriage	27
7. Disassembling and assembling the adaptor	28
8. Disassembling and assembling the sensor for yarn breakage	29
9. Trouble shooting	30

1. FEATURES

1. Automatic knitting is possible.
2. It is possible to knit plain stitch, rib stitch, garter stitch, and multi garter stitch pattern.
3. Automatic casting off is possible.
4. Yarn breakage is sensed by the sensor to stop the carriage automatically.
5. If the number of rows is set, the carriage stops after knitting the set number.
6. The design is selected by utilizing punch cards.
7. Single motif pattern is possible by using the G point cam.
8. Easy operation is possible.

2. SPECIFICATIONS G carriage

1. Knitting system of G carriage	Electric automatic knitting of one-by-one stitch	
2. Knitting speed of G carriage	About 0.6–0.8 sec./stitch (variable in a little range by the volume of the adaptor)	
3. Patterning function	Plain stitch Multi garter stitch pattern (Combination pattern of plain and purl) Casting-off	
4. Needle selection	Same as the knitting machine The needle is not selected preliminarily and the knitting is done while selecting the needle at the same row.	
5. Safety device against trouble	Sensor of yarn breakage Overload automatic stop	
6. Adaptor	*Output of adaptor: variable between 11 and 13V.	
7. Power consumption	20W	
8. Weight	G carriage – 2.2kg Adaptor – 0.9kg	
9. Combination of G carriage and knitting machine	Model of carriage	Model of knitting machine
	KG-89	KH-891 (New model)
	KG-88	KH-881-860* ^① and modified KH910* ^②
	* ^① When the model KG 88 is used with the model KH-881-860, the usage is permitted within the range from 95 on the left to 95 on the right; otherwise, patterning is sometimes impossible.	
	* ^② When the model-88 is used with the model KH-910, the machine should be modified with the new pattern case whole unit. (It is possible to knit all 200 stitches.)	

General Comparison Between KG-88 & 89

Two types of the G carriage are available: KG-88 and 89. Choose the type suitable to the knitting machine to use according to the specification.

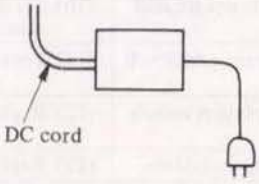
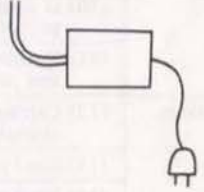
Name of Parts		KG-88	KG-89
G Carriage (Assembly)	1. Step feeder (B45)	• Feed positioning plate and feed plate are shorter as compared with KG-89. (To use auxiliary rack mentioned hereafter.)	For KG-89
	2. G Carriage Foot (B79)	• Groove to fit to rear rail is wider as compared with KG-89. (To use auxiliary rack)	For KG-89
	3. Direction change plate R, L (B91)	• G carriage returns, when moved 32-pitch in the same manner as KG-89. (Because of needle change mechanism of knitting machine)	G carriage returns when moved 26-pitch after G carriage passes end needle of knitting machine.
	4. Magnet Holder (C134)	No need to attach	No need to attach
Adaptor (A18-35)		 <p>DC cord</p>	
		DC cord is so long that adaptor can be located on floor; no place provided for attaching the adaptor on knitting machine.	
Accessory	1. Racks (D21-23)	Rack R, M & L attached (parts for feeding G carriage)	Not provided No need to attach because it has a built-in rack at rear rail of knitting machine.
	2. Tripper (D14-18)	Knit-Leader tripper A Row counter tripper A & knit-leader tripper for KH-860	Knit-Leader tripper A Row counter tripper A
	3. G Point Cams (D10-13)	G point cam L1 G point cam R1 G point cam for 2 needles G point cam for 3 needles (Color: green)	G point cam L1 G point cam R1 G point cam for 2 needles G point cam for 3 needles (Color: sand beige)
	4. Yarn tension Head (D1) (Sensor for yarn breakage can be attached.)	Attached (Because sensor for yarn breakage cannot be attached to yarn sensor head of old-model machine.)	Attached on knitting machine

3. TABLE FOR TROUBLE SHOOTING

Trouble	Probable Cause	Countermeasure	Remark
G carriage does not move from the beginning.	(1) Power cord is not connected with the receptacle.	(1) Connect power cord.	See "Trouble shooting" on page 31 in operation manual.
	(2) Pin plug is not connected.	(2) Connect plug.	
	(3) Detecting bar of sensor for yarn breakage comes down.	(3) Put up the bar over knitting yarn.	
	(4) Electrical system is out of order.	(4) Replace fuse or DC cord (assembly).	
	(5) Row counter is set to "000".	(5) Reset counter.	
	(6) Each knob stops inbetween.	(6) Set knobs properly.	
	(7) Pin comes off cam groove.	(7) Reassemble.	
G carriage stops in the middle of movement.	(8) G needle does not move due to knot and float.	(8) Set G needle for operation and press start key again.	
	(9) Yarn is entangled with yarn tension unit.	(9) Remove entanglement.	
	(10) G point cam (various types) floats and is not located properly.	(10) Set the cam to proper position. (Adjust the curve of rack in case of KG-88.)	
	(11) Needle of knitting machine comes forward position B and gets contact with G carriage.	(11) Locate the needle to position B.	
Motor runs but carriage stops	(12) Carriage feed lever shaft on G carriage plate is loosely assembled.	(12) Replace G carriage plate assembly.	See "Trouble shooting" on page 33.
	(13) Feed positioning plate does not move up and down.	(13) Replace gear mount assembly.	
	(14) Feed plate does not move smoothly and laterally.	(14) Replace step feeder.	
	(15) Height and width of extension rail are improper.	(15) Bend to adjust.	
Carriage moves without automatic return.	(1) Feed change pawl comes off stop needle; it should be caught.	(1) Bend and adjust feed change plate.	See "Trouble shooting" on page 35.
	(2) Feed change pawl does not function smoothly.	(2) Replace feed change plate assembly (R & L).	See "Assembling the G carriage" on page 14.
Motor stops at return position.	(3) Direction change knob does not work smoothly.	(3) Replace G carriage cover upper assembly.	See "Trouble shooting" on page 35.
	(4) Direction change plate assembly (R & L) does not work smoothly.	(4) Replace direction change plate assembly (R & L)	
	(5) Yarn feeder change plate does not smoothly move up and down.	(5) Apply grease or adjust.	
	(6) Allowance for direction change is insufficient.	(6) Adjust connecting plate assembly.	
	(7) Row counter does not function smoothly.	(7) Apply grease or replace.	
	(8) Height and width of extension rail are improper.	(8) Bend to adjust.	
	(9) Needle comes off at position A.	(9) Attach needle.	
	(10) Needle of position A is among needles where fabric hangs.	(10) Knitting by automatic return is impossible.	
Carriage returns at any position where it does not normally returns.	(11) Needle of position A is sometimes lowered.	(11) Replace needle and needle retaining spring.	See Manual KH.

Trouble	Probable Cause	Countermeasure	Remark
Dropping stitches.	(1) G needle is out of order.	(1) Replace G needle.	See "Disassembling the G carriage" on page 6.
	(2) Longitudinal, vertical, and lateral adjustments of gate pegs are bad.	(2) Adjust gate pegs.	
	(3) Tilt of G needle is improper.	(3) Bend and adjust G needle tilting lever assembly.	See "Trouble shooting" on page 36.
	(4) Position of needle guide is bad.	(4) Bend and adjust needle guide.	See "Trouble shooting" on page 37.
	(5) Movement of yarn feeder is improper.	(5) Adjust movement of yarn feeder.	
	(6) Vertical movement of latch presser and yarn feeder is incorrect.	(6) Repair latch presser lever assembly and replace G needle operation cam.	
Stitches which are put normally with the KH needle are made by the G needle. Stitches which are put normally with the G needle are made by the KH needle.	(1) Reader for needle selection gets contact with the release hole of step feeder.	(1) Adjust the release hole of step feeder.	See "Trouble shooting" on page 37.
	(2) Reader does not smoothly move up and down.	(2) Replace upper plate assembly or apply grease.	
	(3) Rubber washer is not located onto the shaft.	(3) Reassemble.	
	(4) Reader spring is not smoothly put to reader.	(4) Replace reader spring.	See "Trouble shooting" on page 37.
	(5) Change lever for knitting needle is not smooth and level.	(5) Adjust change lever level.	
	(6) Change lever rotates at shaft part.	(6) Replace change lever.	
Stop key does not function and row counter does not stop working.	(1) Distance between sensor and magnet is too far.	(1) Adjust motor control board longitudinally, vertically, and laterally.	See "How to adjust the G carriage" on page 28.
	(2) Switch for row counter does not operate smoothly.	(2) Replace row counter.	See "Trouble shooting" on page 38.
	(3) Switch board is out of order.	(3) Replace switch board.	
Sensor for yarn breakage does not work.	(1) Microswitch for sensor for yarn breakage is out of order.	(1) Replace G89 (G88) DC cord whole unit.	See "Trouble shooting" on page 38.
Abnormal sound is generated.	(1) Oil is short between bevel gear Z50 and washer.	(1) Replace bevel gear Z50 and apply grease.	
	(2) Latch of G needle gets contact with gate pegs.	(2) Adjust gate pegs and G needle tilting lever assembly.	See "Trouble shooting" on page 36.
	(3) Yarn feeder gets contact with needle guide.	(3) Adjust the movement of yarn feeder	See "Trouble shooting" on page 37.

Note

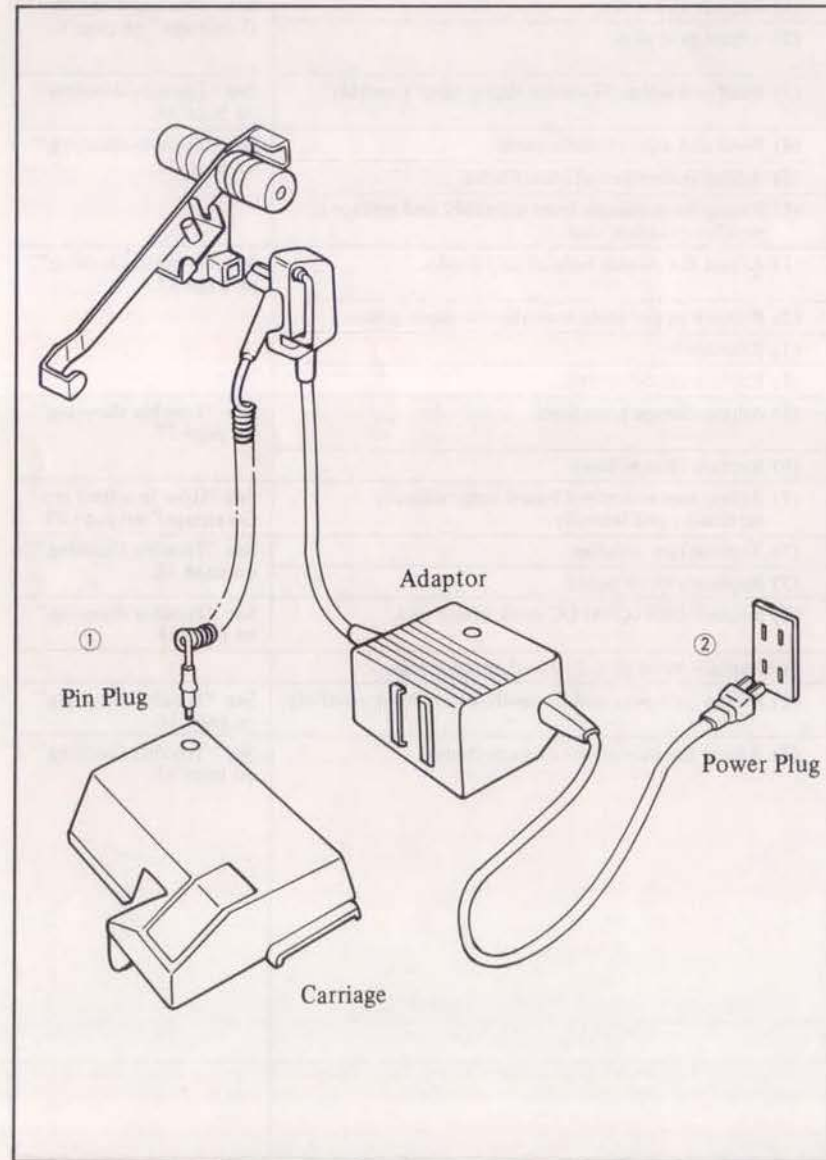

Note 1

Put the pin plug ① of the carriage first for use and then the power plug ② .

Be sure to pull off the power plug ② when not in use?

*If you put and pull the pin plug of the carriage with the power plug connected, the fuse in the adaptor might sometimes melt and break.

Note 2

When you carry the carriage within the box;

- (1) Set the direction change knob to the "right" and turn over the G carriage.
- (2) Check to be sure that the reader for needle selection comes down. If not, repeat starting and stopping until it comes down.

Note 3

When you use improper yarn which cannot be knitted with the G carriage, the carriage will be damaged, which leads to drop stitch. (See "Knitting yarn" on page of the manual.)

Note 4

After you hold up the front part of the carriage and move just for no-load running, be sure to put it down slowly at the position A where no fabric is hunged; otherwise, the stitch cam guide plate might be damaged.

Note 5

When you put down the carriage onto the needle bed after holding up and moving its front part, be sure to move the carriage laterally to put it down if there is clearance provided between the G carriage cover and the foot. (If you force the carriage down, the feed pawl of the step feeder might be damaged. (See the page 18 on the manual.)

4. DISASSEMBLING THE G CARRIAGE

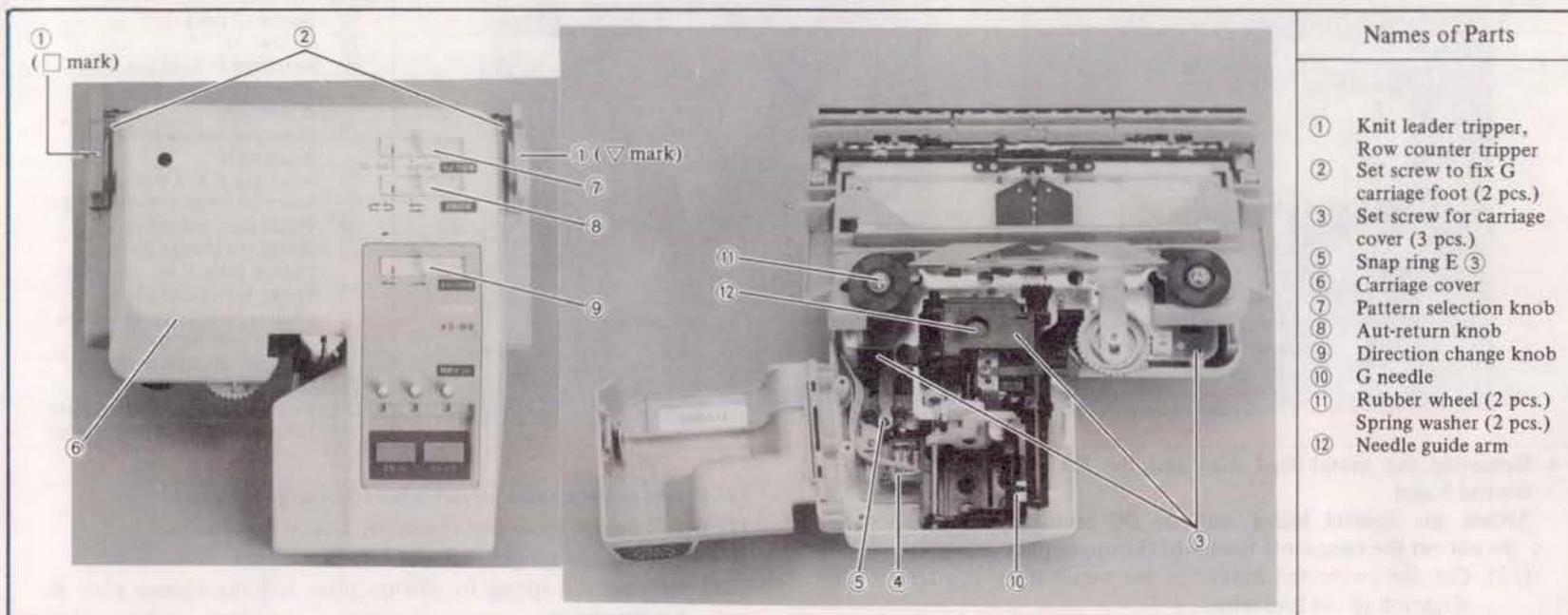

Names of Parts

- ① Knit leader tripper, Row counter tripper
- ② Set screw to fix G carriage foot (2 pcs.)
- ③ Set screw for carriage cover (3 pcs.)
- ⑤ Snap ring E ③
- ⑥ Carriage cover
- ⑦ Pattern selection knob
- ⑧ Aut-return knob
- ⑨ Direction change knob
- ⑩ G needle
- ⑪ Rubber wheel (2 pcs.)
- ⑫ Spring washer (2 pcs.)
- ⑫ Needle guide arm

● Removing the carriage cover

(1) Pull out the leader tripper (▽ mark) and the row counter tripper (□ mark).

(2) Remove the right and left set screws to fix the G carriage foot.

***When only the G carriage cover is removed and the DC motor is replaced, they can be detached, just by loosening the screws some 3 mm.**

(3) Open the lower carriage cover and the needle guide arm ⑫ to the left and remove one set screw and the right and left screws.

(4) Remove the connector of the motor control board from the switch board.

***Do not pull the lead wire by force.**

(5) Remove the snap ring E ③ to detach the row counter connecting plate (See Fig. on page 25.)

(6) Remove the carriage cover.

(7) The pattern selector knob comes off.

(8) The aut-return knob comes off.

(9) The direction change knob comes off.

● Removing the G needle

(10) Pull out the G needle.

● Removing the rubber wheel

(11) Remove the right and left screw to fix the rubber wheels and detach the rubber wheels and the spring washers.

● Removing the needle guide arm

(12) Detach the needle guide arm assembly.

Disassembling the G carriage

		<table border="1"> <thead> <tr> <th colspan="2">Names of Parts</th> </tr> </thead> <tbody> <tr><td>⑬</td><td>Binder (2 pcs.)</td></tr> <tr><td>⑭</td><td>Connector</td></tr> <tr><td>⑮</td><td>Snap ring E ③ (2 pcs.)</td></tr> <tr><td>⑯</td><td>Direction change lever A assembly</td></tr> <tr><td>⑰</td><td>Direction change lever B assembly</td></tr> <tr><td>⑱</td><td>Snap ring E ④ (4 pcs.)</td></tr> <tr><td>⑲</td><td>Screw to fix gear mount (3 pcs.)</td></tr> <tr><td>⑳</td><td>Upper plate assembly</td></tr> <tr><td>㉑</td><td>Spring for change plate Change plate R for aut-return</td></tr> <tr><td>㉒</td><td>Spring for change plate Change plate L for aut-return</td></tr> <tr><td>㉓</td><td>G needle tilting cam</td></tr> <tr><td>㉔</td><td>G needle tilt lever assembly</td></tr> <tr><td>㉕</td><td>Gear mount assembly</td></tr> <tr><td>㉖</td><td>Row counter connecting plate</td></tr> <tr><td>㉗</td><td>Bevel gear & bevel gear washer</td></tr> </tbody> </table>	Names of Parts		⑬	Binder (2 pcs.)	⑭	Connector	⑮	Snap ring E ③ (2 pcs.)	⑯	Direction change lever A assembly	⑰	Direction change lever B assembly	⑱	Snap ring E ④ (4 pcs.)	⑲	Screw to fix gear mount (3 pcs.)	⑳	Upper plate assembly	㉑	Spring for change plate Change plate R for aut-return	㉒	Spring for change plate Change plate L for aut-return	㉓	G needle tilting cam	㉔	G needle tilt lever assembly	㉕	Gear mount assembly	㉖	Row counter connecting plate	㉗	Bevel gear & bevel gear washer
Names of Parts																																		
⑬	Binder (2 pcs.)																																	
⑭	Connector																																	
⑮	Snap ring E ③ (2 pcs.)																																	
⑯	Direction change lever A assembly																																	
⑰	Direction change lever B assembly																																	
⑱	Snap ring E ④ (4 pcs.)																																	
⑲	Screw to fix gear mount (3 pcs.)																																	
⑳	Upper plate assembly																																	
㉑	Spring for change plate Change plate R for aut-return																																	
㉒	Spring for change plate Change plate L for aut-return																																	
㉓	G needle tilting cam																																	
㉔	G needle tilt lever assembly																																	
㉕	Gear mount assembly																																	
㉖	Row counter connecting plate																																	
㉗	Bevel gear & bevel gear washer																																	
<ul style="list-style-type: none"> ● Removing the motor lead wire and the lead wire for the motor control board *When the control board and the DC motor are not removed, do not cut the connected binder of the upper plate assembly. (13) Cut the connected binder of the upper plate assembly with attention to the lead wire. (14) Remove the connector of the DC motor which connects with the control board. (When only DC motor is remove, see page 27.) Note: Do not pull the lead wire. *See "Adjusting the control board" on page 28 for removing the control board. ● Removing the direction change lever A assembly and the direction change lever B assembly (15) Remove the two snap rings E ③ for the direction change levers A and B assembly. (16) Remove the direction change lever A assembly. (17) Remove the direction change lever B assembly. ● Removing the upper plate assembly (18) Remove the four snap rings E ④ which fixes the upper plate assembly. 	<ul style="list-style-type: none"> (19) Remove the three screws which fix the gear mount. (20) Pull up the upper plate assembly slowly for removal. ● Removing the change plates R and L for aut-return (21) Remove the spring for change plate and the change plate R for aut-return. (22) Remove the spring for change plate and the change plate L for aut-return. ● Removing the G needle tilting cam (23) Pull out the G needle tilting cam. ● Removing the G needle tilt lever assembly (24) Remove the G needle tilt lever assembly. ● Removing the gear mount assembly and the row counter connecting plate (25) The gear mount assembly comes off. (26) And the row counter connecting plate comes off at the same time. ● Removing the bevel gear (27) Removing the bevel gear and the bevel gear washer. 																																	

Disassembling the G carriage

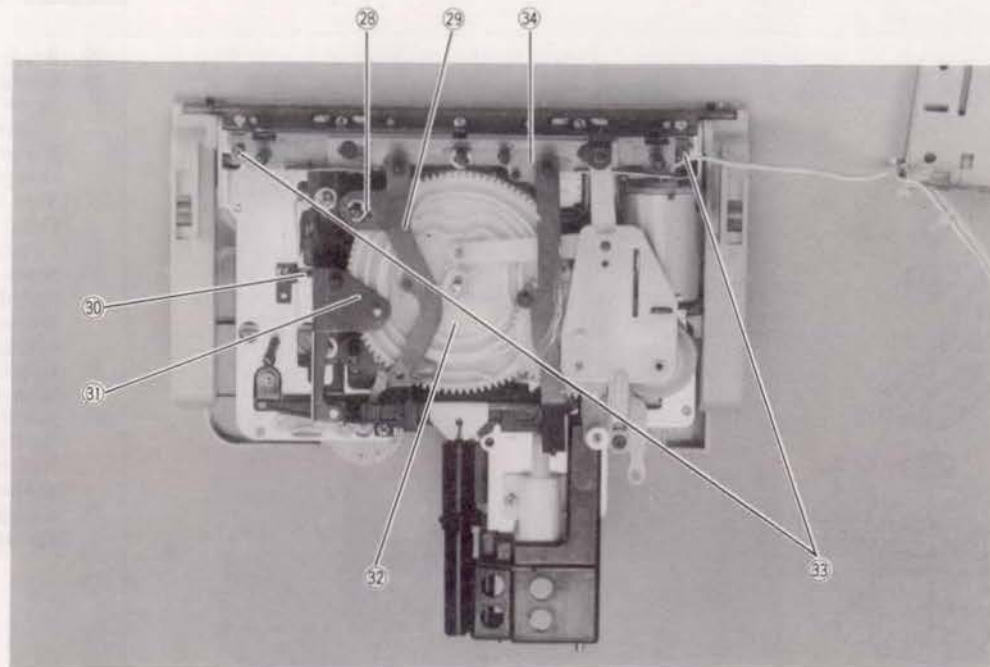

Names of Parts

- ②⑧ Snap ring E ④ & washer
- ②⑨ Latch presser lever
- ③⑩ Yarn feeder change cam spring
screw to fix yarn feeder change cam spring
- ③① Yarn feeder change plate
- ③② G needle operation cam
- ③③ Screw for step feeder (2 pcs.)
- ③④ Step feeder

- **Removing the latch presser lever**

(28) Remove the snap ring E ④ and the washer for the latch presser lever.

(29) Remove the latch presser lever assembly and the washer.

- **Removing the yarn feeder change cam spring**

(30) Remove the screw for the yarn feeder change cam spring and detach the yarn feeder change cam spring.

- **Removing the yarn feeder change plate assembly and the G needle operation cam**

(31) Pull out the yarn feeder change plate by turning its shaft part.

(32) Pull out the G needle operation cam.

- **Removing the step feeder**

(33) Remove the right and left two screws which fix the step feeder.

(34) Pull up and remove the step feeder slowly.

***Pay attention to the lead wire for the DC motor.**

Disassembling the G carriage

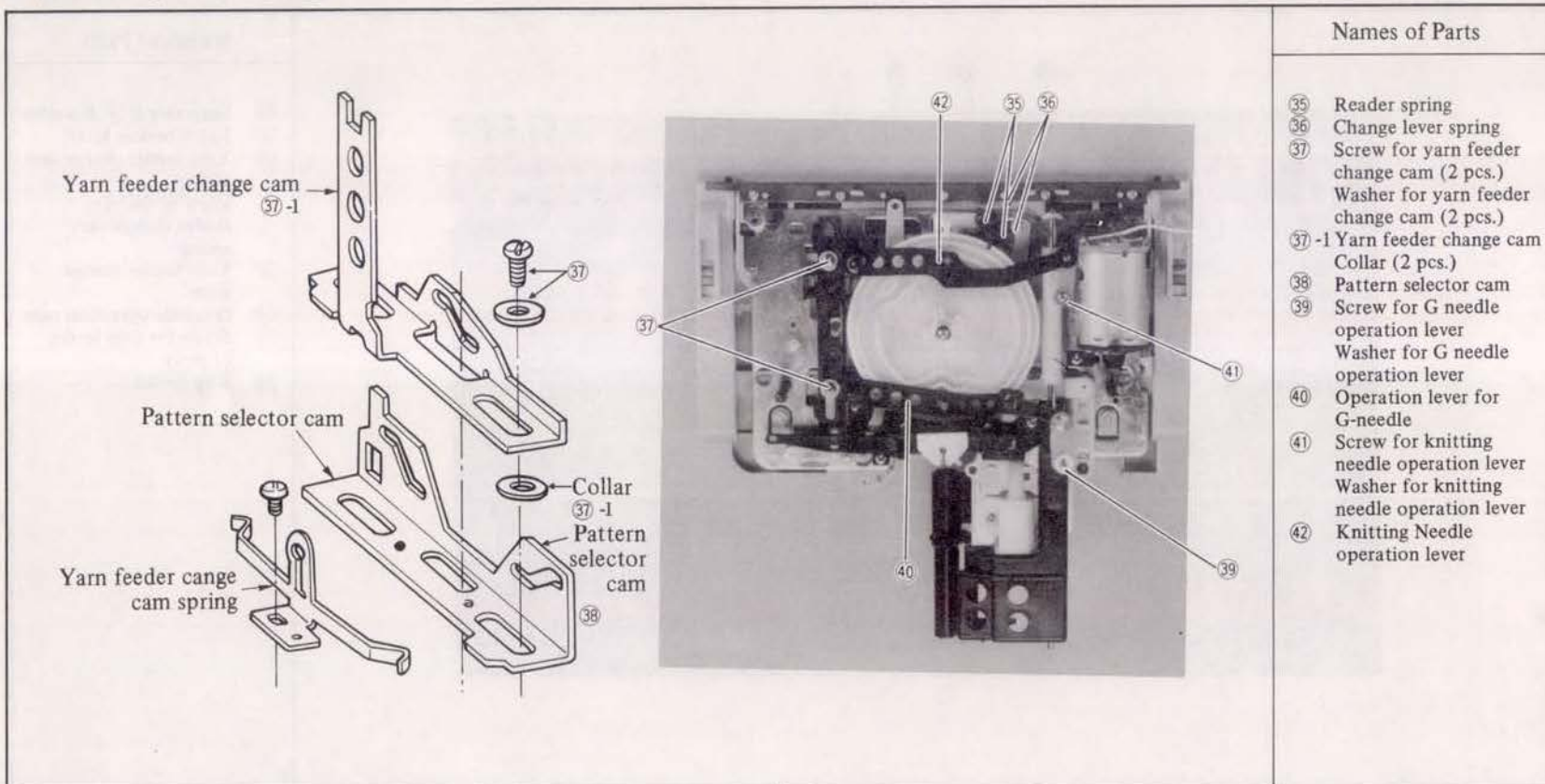

Names of Parts

- (35) Reader spring
- (36) Change lever spring
- (37) Screw for yarn feeder change cam (2 pcs.)
- Washer for yarn feeder change cam (2 pcs.)
- (37)-1 Yarn feeder change cam
- Collar (2 pcs.)
- (38) Pattern selector cam
- (39) Screw for G needle operation lever
- Washer for G needle operation lever
- (40) Operation lever for G-needle
- (41) Screw for knitting needle operation lever
- Washer for knitting needle operation lever
- (42) Knitting Needle operation lever

- (35) The reader spring comes off.
- (36) The change lever spring comes off.
- **Removing the yarn feeder change cam and the pattern selector cam**
- (37) Remove the two screws and washers for the yarn feeder change cam.
- (37)-1 Remove the yarn feeder change cam and remove the two collars located under it.
- (38) Remove the pattern selector cam.

- **Removing the operation lever for G needle assembly**
- (39) Remove the screw and washer for the G needle operation lever assembly.
- (40) The operation lever for G needle assembly comes off.
- **Removing the knitting needle operation lever assembly.**
- (41) Remove the screw and washer for the knitting needle operation lever assembly.
- (42) Remove the knitting needle operation lever assembly.

Disassembling the G carriage

		Names of Parts
<ul style="list-style-type: none"> ● Removing the G carriage feeding cam <ul style="list-style-type: none"> (43) Reader for needle selection assembly (44) Change lever for knitting needle assembly (45) G carriage feeding cam Pull out and remove all these three parts at the same time and remove the rubber washer located under the shaft of the reader for needle selection assembly. ● Removing the G needle operation shaft <ul style="list-style-type: none"> (46) Remove the G needle swing cam spring. (46) -1 Remove the snap ring E 2.5 for the G needle operation shaft. (47) Pull out the G needle operation shaft. (48) Remove the G needle operation arm. 	<ul style="list-style-type: none"> ● Removing the G carriage feeding lever <ul style="list-style-type: none"> (49) Pull out the G carriage feeding lever. (50) Presser plate for spring hanger (51) Spring hanger plate, upper (52) Spring hanger plate, lower (53) Direction change lever spring (54) Direction change lever Release the fit with the yarn feeder support assembly and pull them up at the same time. 	

Disassembling the G carriage

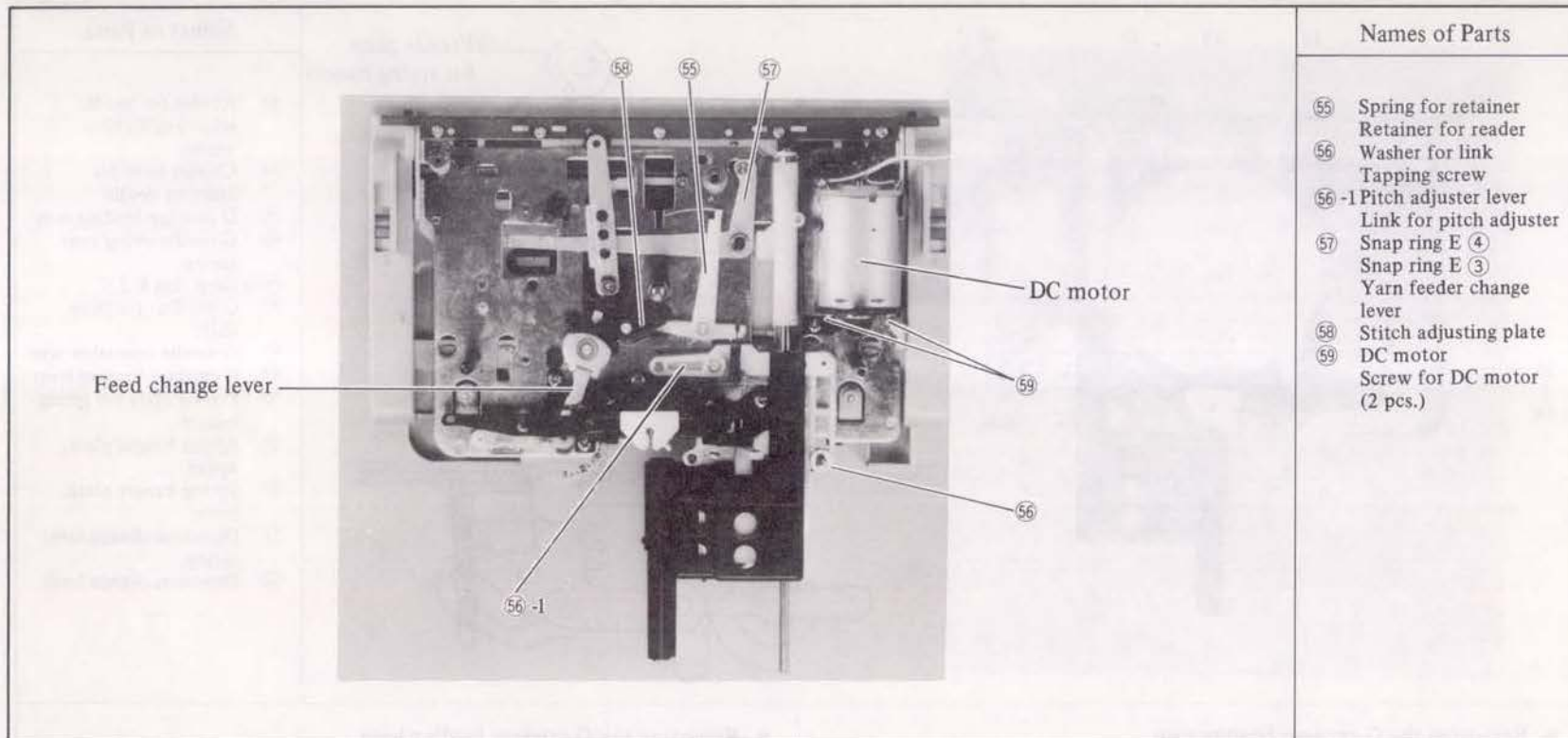

Names of Parts

- ⑤⑤ Spring for retainer
Retainer for reader
- ⑤⑥ Washer for link
Tapping screw
- ⑤⑥-1 Pitch adjuster lever
Link for pitch adjuster
- ⑤⑦ Snap ring E ④
Snap ring E ③
Yarn feeder change
lever
- ⑤⑧ Stitch adjusting plate
- ⑤⑨ DC motor
Screw for DC motor
(2 pcs.)

● Removing the spring for retainer

(55) Remove the spring for retainer and the retainer for reader over it.

● Removing the link

(56) Remove the washer and tapping screw for the link for pitch adjuster.

(56)-1 Remove the pitch adjuster lever and the link for pitch adjuster.

● Removing the yarn feeder change lever

(57) Remove the snap ring E ④ and the snap ring E ③ for the yarn feeder change lever. Remove the yarn feeder change lever.

(58) The stitch adjusting plate comes off.

● Removing the DC motor

(59) Remove the DC motor by loosening the two screws.

(When only DC motor is changed, see "How to replace the DC motor only" page 27.)

Disassembling the G carriage

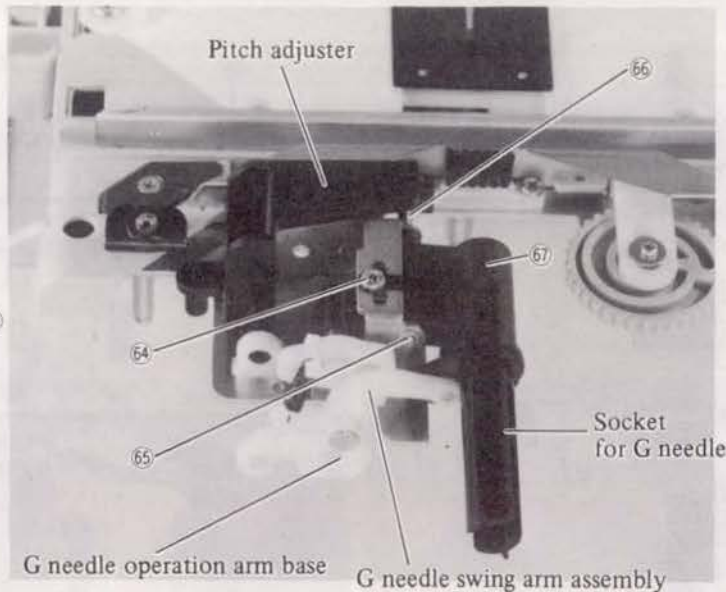
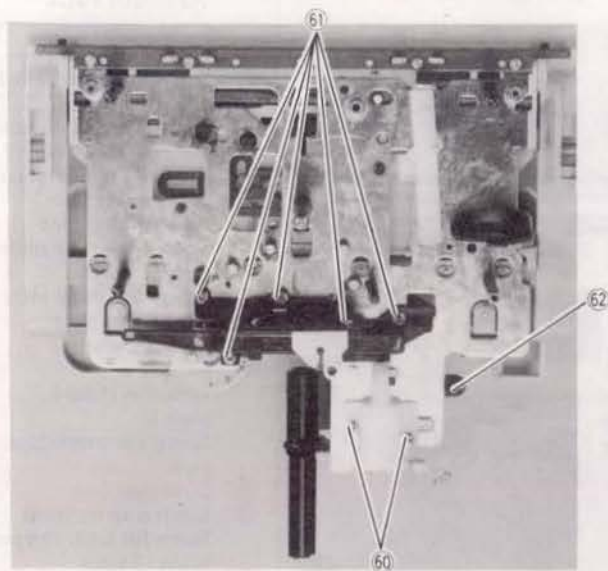

Names of Parts

- ⑥0 Screw for G needle operation arm (2 pcs.)
- ⑥1 Screw for yarn feeder holder (5 pcs.)
- ⑥2 Yarn feeder unit
- ⑥3 G needle swing arm assembly
- Pitch adjuster
- G needle operation arm base
- ⑥4 Spring for G needle socket
- Screw for G needle socket
- ⑥5 Snap ring E ②
- ⑥6 Stud
- ⑥7 Arm for socket

● Removing the yarn feeder unit

- (60) Remove the two screw for the G needle operation arm.
- (61) Remove the five screws for the yarn feeder holder.
- (62) Release the fitting with the pitch adjuster and remove the yarn feeder unit.

*When it is necessary to disassemble the yarn feeder unit;

(See the page 17 for assembly.)

Remove the two snap ring E ② for yarn feeder unit and pull out the stud, so that the following parts come off.

- 1 Washer for yarn feeder change cam
- 2 Latch presser plate change cam
- 3 Yarn feeder up-down change cam
- 4 Yarn feeder holder bracket L

- 5 Yarn feeder holder bracket R
- 6 Yarn feeder
- 7 O ring
- 8 Latch presser plate assembly
- 9 Yarn feeder holder assembly

(63) Remove the pitch adjuster, the G needle swing arm assembly, the G needle operation arm base, and the socket for G needle.

● Removing the arm for socket

- (64) Remove the screw for the plate spring and remove the plate spring.
- (65) Remove the snap ring E ② of the stud.
- (66) Pull out the stud.
- (67) Remove the arm for socket.

Disassembling the G carriage

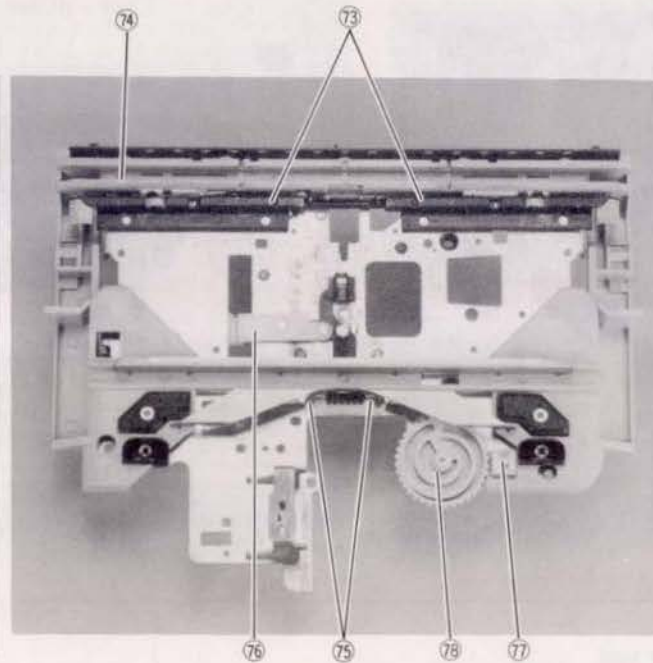
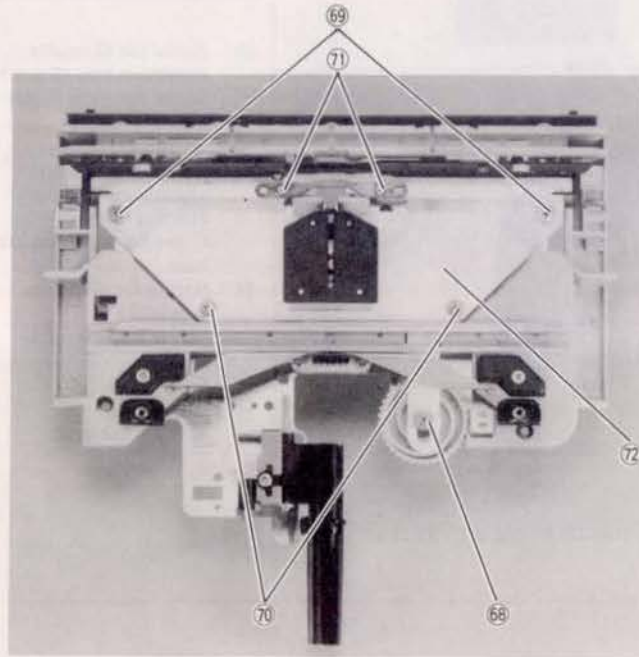

Names of Parts

- ⑥8 Screw/washer for stitch dial
- ⑥9 Screw A for stitch cam guide plate (2 pcs.)
- ⑦0 Screw B for stitch cam guide plate (2 pcs.)
- ⑦1 Needle guide plate
Screw for needle guide plate (2 pcs.)
- ⑦2 Stitch cam guide plate
- ⑦3 Connecting plate
Direction change plate R
Direction change plate L
Spring for connecting plate
- ⑦4 G carriage foot
- ⑦5 Latch stopper brush
Screw for latch stopper brush (2 pcs.)
- ⑦6 Arm for needle operation
- ⑦7 Stitch dial lever
Roller and spring
- ⑦8 Stitch dial
Stitch dial lever/screw

• Removing the stitch cam guide plate assembly

- (68) Remove the screw and washer for the stitch dial.
- (69) Remove the two screws A for the stitch guide cam plate.
- (70) Remove the two screws B for the stitch guide cam plate.
- (71) Remove the needle guide plate by loosening the two screws.
- (72) Open the G carriage foot assembly and remove the stitch cam guide plate.

• Removing the following parts

- (73) The connecting plate, the direction change plate R & L and spring comes off at the same time.

- (74) Remove the G carriage foot.

• Removing the latch stopper brush

- (75) Remove the latch stopper brush by loosening the screw.
- (76) Remove the arm for needle operation.

• Removing the stitch dial lever

- (77) Open the cover for the stitch dial lever and remove the spring and the roller.
- (78) Pull out the stitch dial and remove the screw and the stitch dial lever.

5. ASSEMBLING THE G CARRIAGE

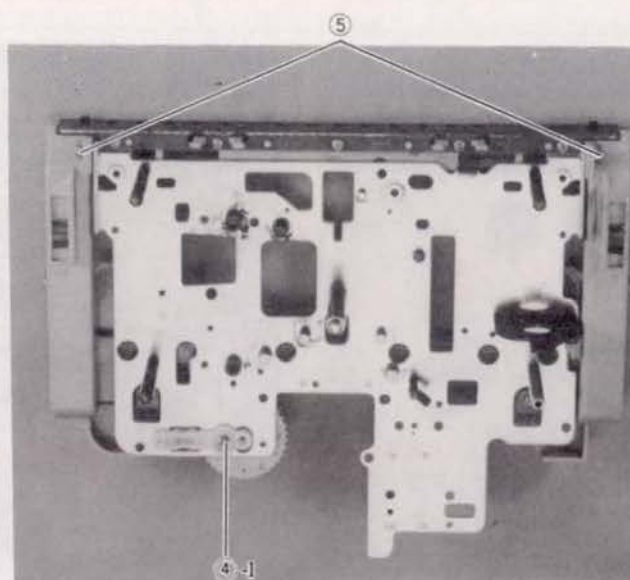
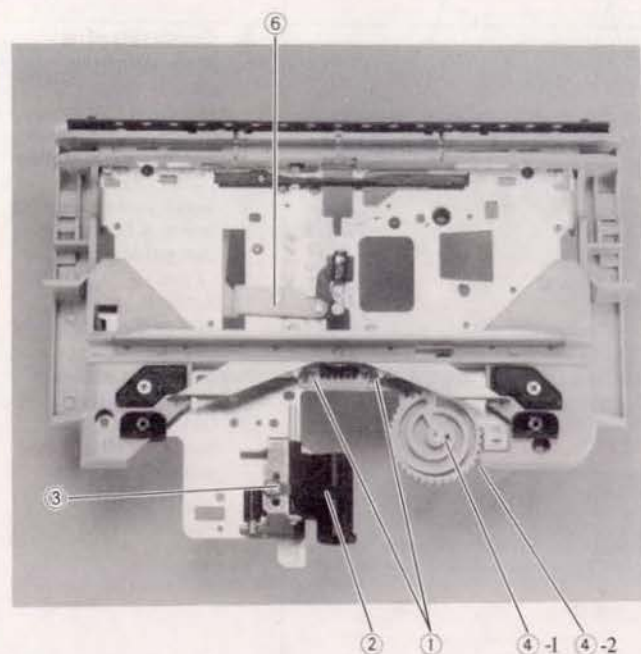

Names of Parts

- ① Latch stopper brush
Screw for latch
stopper brush (2 pcs.)
- ② Arm for socket
Snap ring E ②
Stud
- ③ Spring for G needle
socket
- ④-1 Stitch dial lever
- ④-2 Stitch dial
- ④-3 Roller, spring and cover
- ⑤ G carriage foot
- ⑥ Arm for needle
operation

- **Mounting the latch stopper brush**

- (1) Attach the right and left screws to the latch stopper brushes.

- **Mounting the arm for socket**

- (2) Mount the arm for socket onto the socket base, insert the stud from the back, and fix the arm with the snap ring ②.

- (3) Attach the spring for G needle socket with screws.

- **Mounting the stitch dial**

- (4)-1 Mount the stitch dial lever onto the G carriage plate and fix it with screw temporarily.

- (4)-2 Set the stitch dial to the stitch dial lever.

- (4)-3 Put the roller and spring into the groove of the stitch dial lever and set the cover.

- **Mounting the G carriage foot assembly**

- (5) Fix the G carriage foot assembly temporarily with screws at two positions so that it may not come inside the G carriage plate.

- **Mounting the arm for needle operation**

- (6) Put the arm for needle operation through the hole of the G carriage plate.

Assembling the G carriage

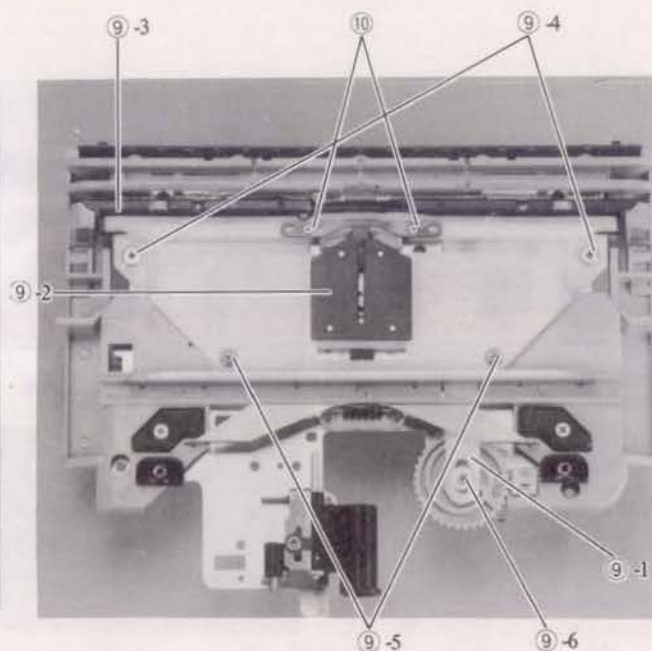
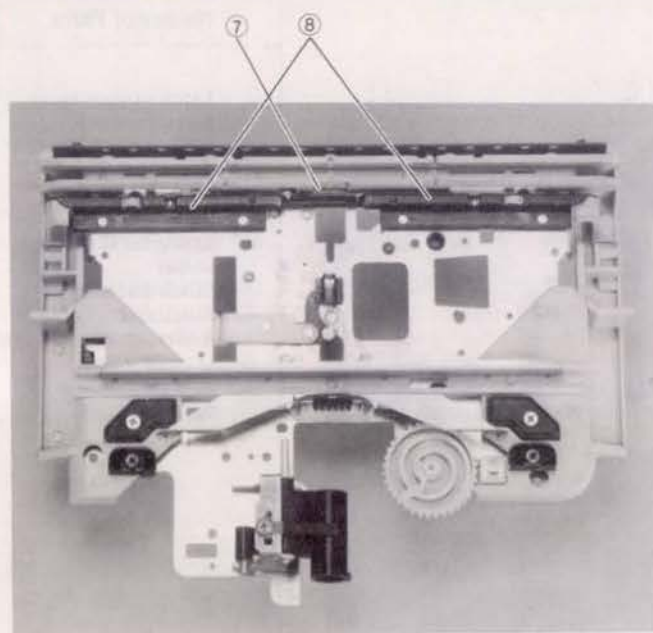

Names of Parts

- ⑦ Connecting plate
- ⑧ Direction change plate R
Direction change plate L
Spring for connecting plate
- ⑨ Stitch cam guide plate
- ⑨-4 Screw A for stitch cam guide plate (2 pcs.)
- ⑨-5 Screw B for stitch cam guide plate (2 pcs.)
- ⑨-6 Stitch dial washer
Stitch dial screw
- ⑩ Guide plate
Screw for stitch cam guide plate (2 pcs.)

- **Mounting the connecting plate and the direction change plate R and L.**

- (7) Put the pin of the connecting plate through the oval hole of the G carriage.
- (8) Mount the direction change plate R and L which pull against each other with the spring for connecting plate so that the cut parts of the direction change plate may fit to the both ends of the connecting plate.

- **Mounting the stitch cam guide plate; set the stitch dial to 7**

- (9)-1 Put the boss of the stitch cam guide plate into the groove of the stitch dial knob.
- (9)-2 Put and fit the arm for needle operation into the center groove of the stitch cam assembly.

- (9)-3 Widen the space between the direction change plate R and L a little in both lateral directions and fit to the stitch cam guide plate.

- **Check to be sure that the stitch dial rotates and each part securely fit to the stitch cam guide plate.**

- (9)-4 Fix the stitch cam guide plate with two screws A.
- (9)-5 Fix the stitch cam guide plate with two screws B.
- (9)-6 Fit the stitch dial lever with stitch dial washer and screws.
- *Adjust the yarn take-up dimension; see the page 27.

- **Mounting the stitch cam guide plate**

- (10) Fix the stitch cam guide plate with screws so that the chamfers of the holes of the stitch cam guide plate may be kept upward.

Assembling the G carriage

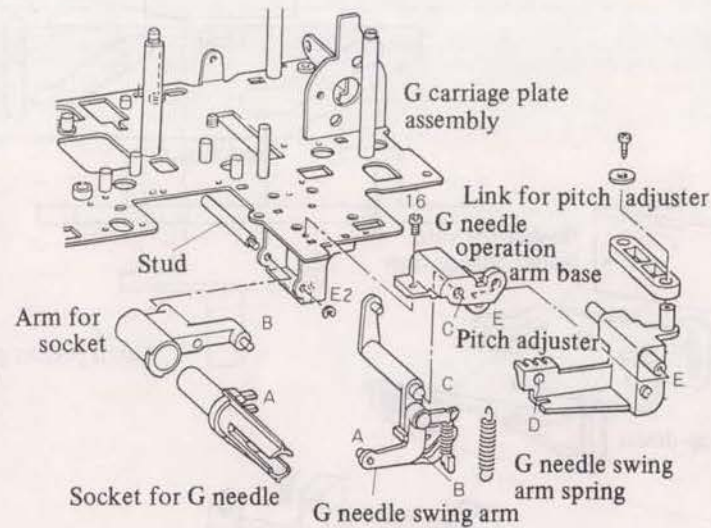
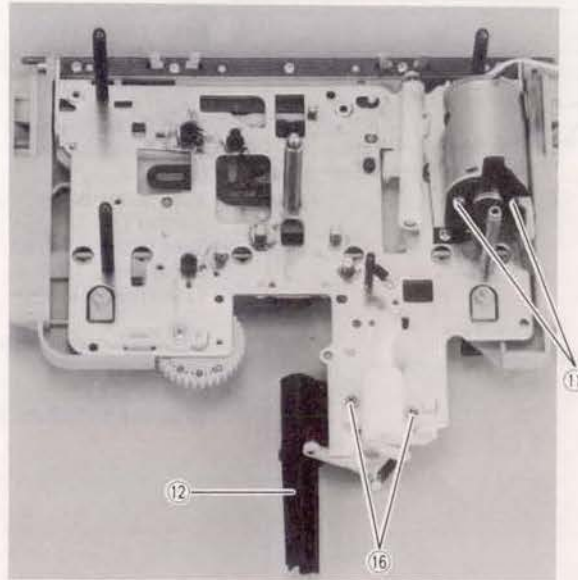

Names of Parts

- ⑪ DC motor
Screw for DC motor
(2 pcs.)
- ⑫ Socket for G needle
- ⑬ G needle swing arm
- ⑭ G needle operation
arm base
- ⑮ Pitch adjuster
- ⑯ Screw for G needle
operation base (2 pcs.)

- **Mounting the DC motor**
(11) Mount and fix the DC motor with two screws so that the condenser side may be located on the right side.
- **Mounting the socket for G needle**
(12) Put the socket for G needle into the hole of the arm for socket.
- **Mounting the G needle swing arm, the G needle operation base, and the pitch adjuster**
(13) Put the pin A of the G needle swing arm into the open part

- (14) Put the boss C of the G needle swing arm into the hole C of the G needle operation arm base and fit them to the carriage plate.
- (15) Open the foot assembly of the G carriage and fit the hole D of the pitch adjuster to the stud. At this time, put the boss E of the pitch adjuster into the hole E of the G needle operation arm base.
- (16) Fix the G needle operation arm base temporarily with two screws.

Assembling the G carriage (assembling the yarn feeder unit)

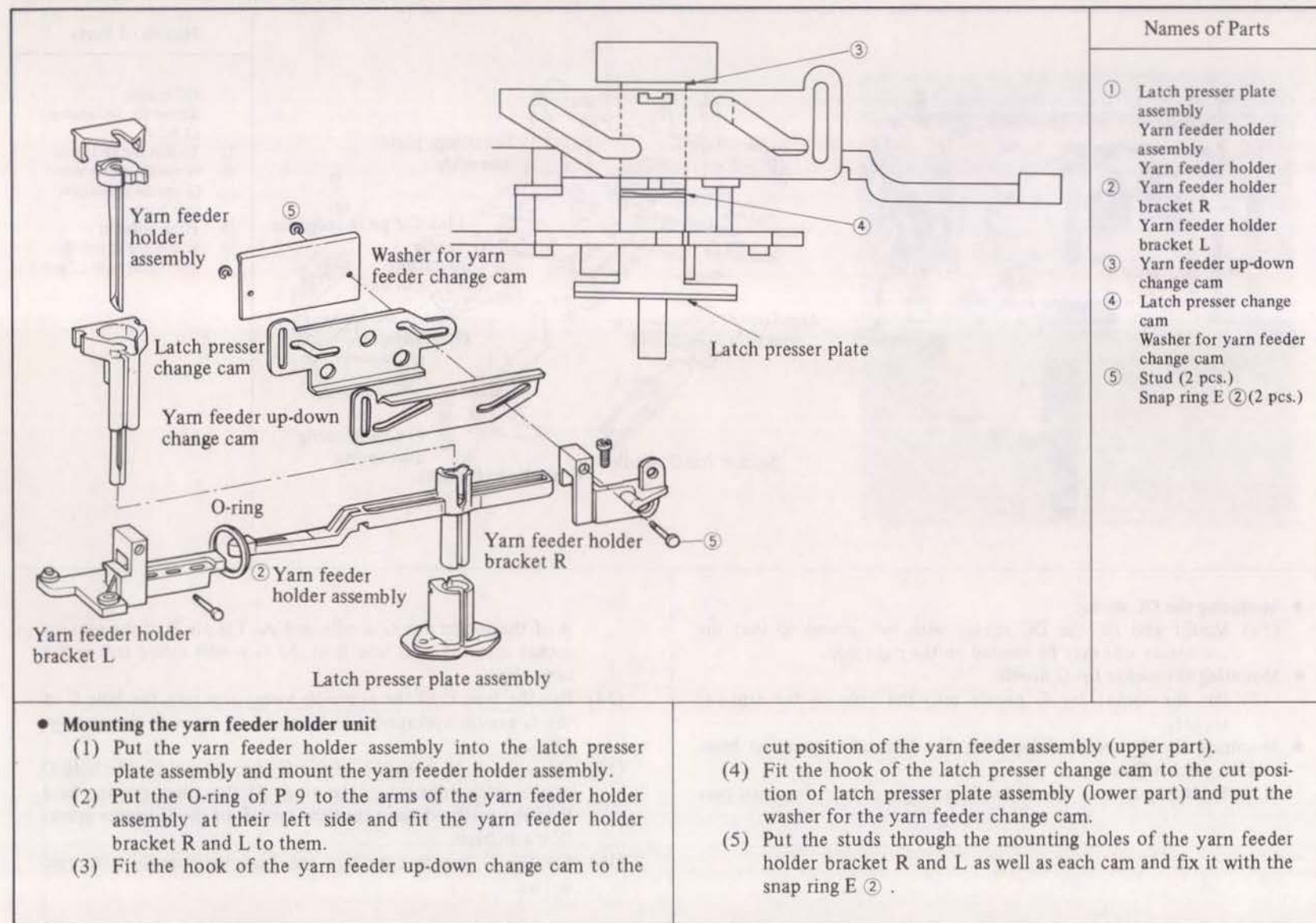

● **Mounting the yarn feeder holder unit**

- (1) Put the yarn feeder holder assembly into the latch presser plate assembly and mount the yarn feeder holder assembly.
- (2) Put the O-ring of P 9 to the arms of the yarn feeder holder assembly at their left side and fit the yarn feeder holder bracket R and L to them.
- (3) Fit the hook of the yarn feeder up-down change cam to the

- cut position of the yarn feeder assembly (upper part).
- (4) Fit the hook of the latch presser change cam to the cut position of latch presser assembly (lower part) and put the washer for the yarn feeder change cam.
- (5) Put the studs through the mounting holes of the yarn feeder holder bracket R and L as well as each cam and fix it with the snap ring E ② .

Assembling the G carriage

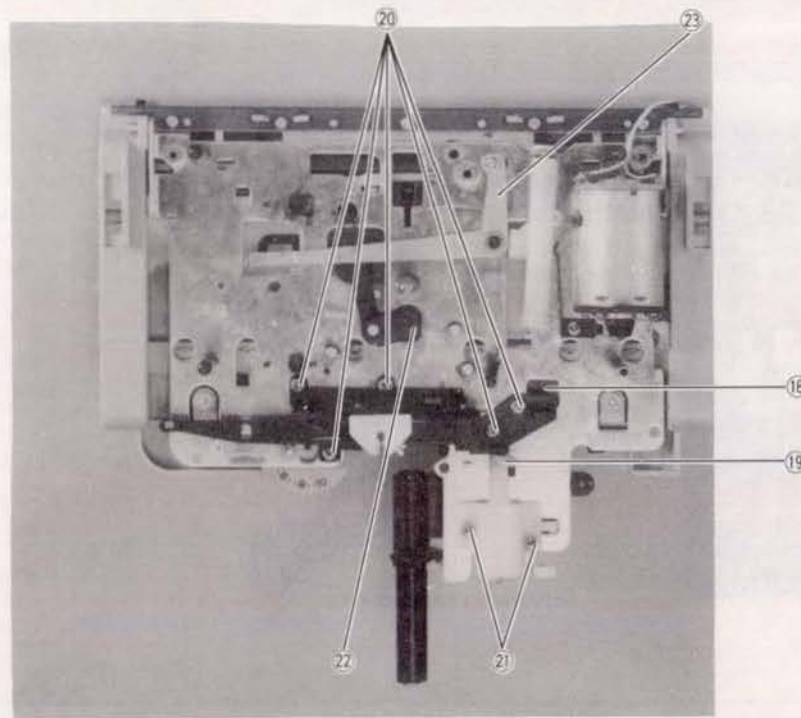

Names of Parts

- ⑱ Yarn feeder unit assembly
- ⑳ Screw for yarn feeder holder bracket (5 pcs.)
- ㉑ Screw for G needle operation arm base
- ㉒ Stitch adjuster plate
- ㉓ Yarn feeder change lever
- Snap ring E ④
- Snap ring E ③

- **Mounting the yarn feeder holder unit**

- (18) Slide the pitch adjuster forward and put the yarn feeder holder bracket R of the yarn feeder unit into the square hole of the G carriage plate.
- (19) Put the boss of the pitch adjuster into the hole of the yarn feeder holder bracket R and put the boss of the yarn feeder holder bracket R into the hole of the G needle swing arm.
- (20) Fix the yarn feeder holder bracket R and L with five screws.
- (21) Fix the G needle operation arm base with two screw.

- **Mounting the stitch adjuster plate assembly**

- (22) Put the pin of the stitch adjuster plate assembly into the pin of the G carriage plate while putting it into the groove of the stitch adjuster cam.

- **Mounting the yarn feeder change lever**

- (23) Fix the yarn feeder change lever into the pin of the G carriage plate with the snap ring ④ and into the pin of the connecting plate with the snap ring ③

Assembling the G carriage

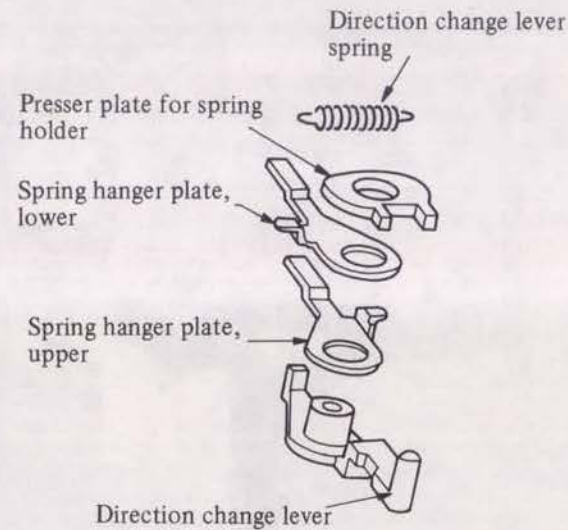
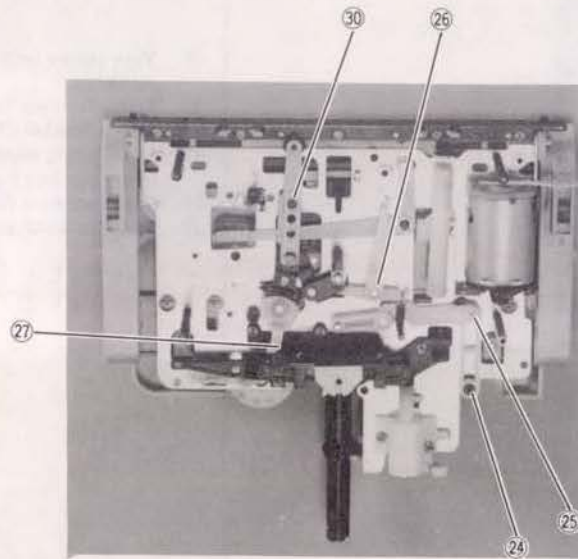

Names of Parts

- ②④ Link for pitch adjuster
Washer/tapping screw
- ②⑤ Pitch adjuster lever
- ②⑥ Retainer for reader
- Spring for retainer
- ②⑦ Direction change lever
- ②⑧ Spring hanger plate, upper
- Spring hanger plate, lower
- Direction change lever spring
- ②⑨ Presser plate for spring holder
- ③⑩ Carriage feeding lever
Roller for carriage feeding lever

- **Mounting the link for pitch adjuster and the pitch adjuster lever**
(24) Set the hole of the link for pitch adjuster to the boss of the pitch adjuster and fix them with the washer and tapping screw.
(25) Put the pitch adjuster lever into the pin of the G carriage plate while putting it into the hole of the link for pitch adjuster.
- **Mounting the retainer for reader**
(26) Attach the retainer for reader with the spring hooked to the G carriage plate; mount so that the one arm may be located between the stitch adjuster plates.
- **Mounting the direction change lever**
(27) Put the boss (longer part) of the direction change lever into

the cut part of the yarn feeder holder assembly and put it into the pin of the G carriage plate.

- (28) Attach the spring hanger plate lower and upper to the direction change lever and hook the direction change lever spring.
- * **Attach the presser plate for spring holder to the direction change lever.**
- **Mounting the carriage feeding lever**
(30) Widen the upper and lower direction change lever spring to attach the carriage feeding lever.
(30) -1 Put the roller to the pin of the carriage feeding lever.

Assembling the G carriage

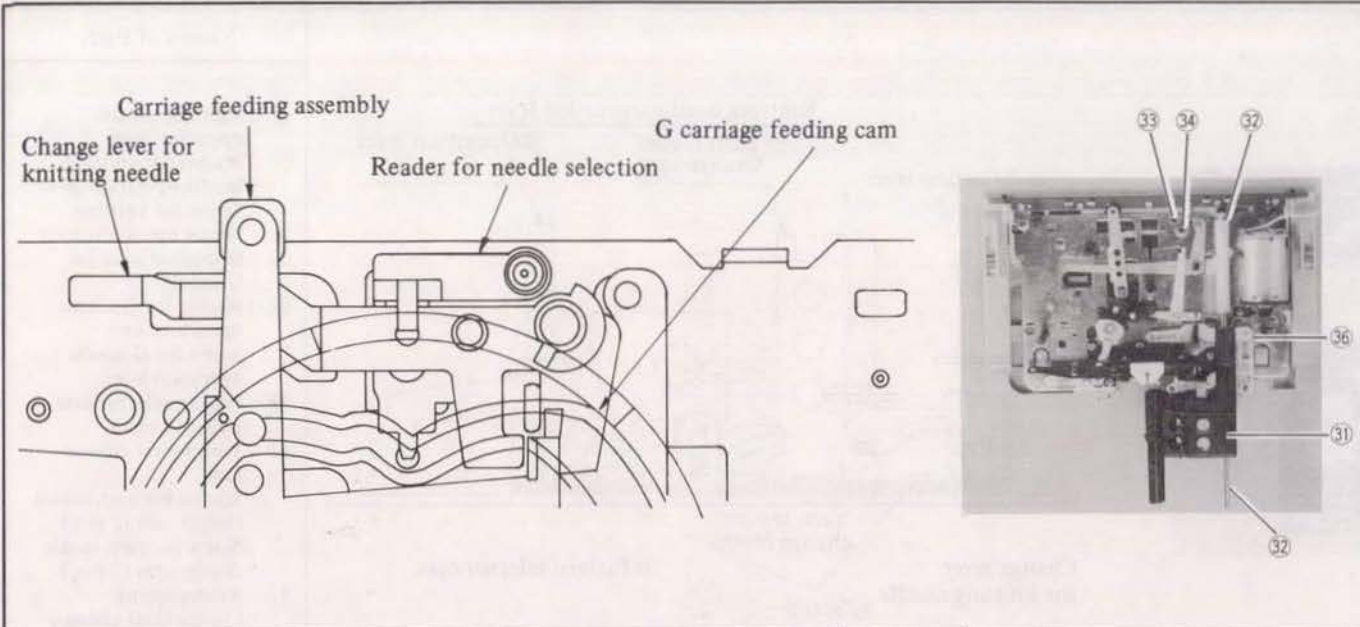
		Names of Parts
<ul style="list-style-type: none"> ● Mounting the G needle operation arm assembly <ul style="list-style-type: none"> (31) Put and fit the cut part of the G needle operation arm assembly into the G carriage plate. (32) Put the G needle operation shaft from the front side through holes of the G needle operation arm assembly, the G needle operation base, the yarn feeder holder bracket R, the arm for needle operation, and the G carriage plate and fix the shaft with the snap ring E 2.5. Fit the G needle swing cam spring to the shaft. (See No. 46 on page 10.) ● Mounting the reader for needle selection <ul style="list-style-type: none"> (33) Put the rubber washer to the shaft of the reader for needle selection and place the reader for needle selection on the carriage plate. (34) Put the change lever for knitting needle under the carriage feeding lever and onto the G carriage. ● Mounting the carriage feeding cam 	<ul style="list-style-type: none"> (35) Locate the pitch adjuster in the rear. *Keep the carriage feeding lever straight. (36) Keep the lower part of the periphery of the carriage feeding cam in the rear and put it toward the reader for needle selection. Then fit to the carriage feeding cam while lifting up the hooks of the change lever for knitting needle and the reader for needle selection. Assemble the carriage feeding cam, the reader for needle selection, and the change lever for knitting needle securely. *When assembling the carriage feeding cam, check to be sure that the pins of the following parts are properly set to the grooves of the cam; the stitch dial cam, carriage feeding cam, the pitch adjuster cam, and the pattern selector cam are arranged in this order from the inside. *Put the hooks of the change lever for knitting needle and the reader for needle selection onto the high of the carriage feeding cam and check to be sure that it can be rotated clockwise by hand. 	<ul style="list-style-type: none"> (31) G needle operation arm assembly (32) G needle operation shaft Snap ring E 2.5 G needle swing cam spring (33) Reader for needle selection/rubber washer (34) Change lever for knitting needle (36) G carriage feeding cam

Assembling the G carriage

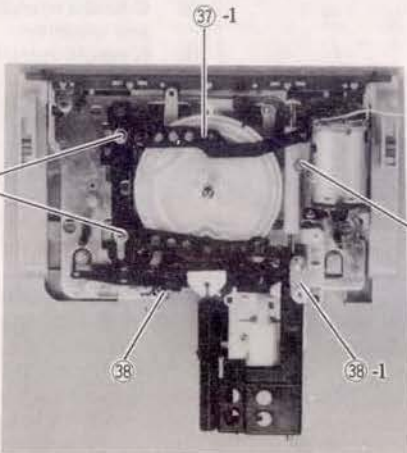
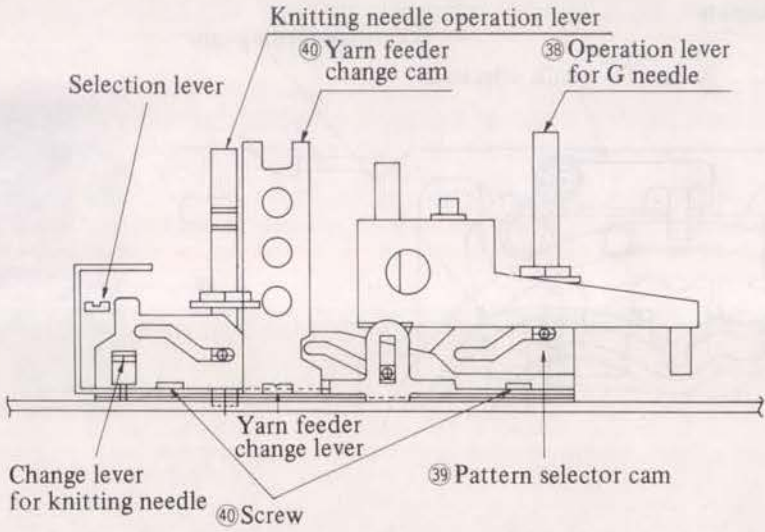
		Names of Parts
	 <p>Selection lever</p> <p>Knitting needle operation lever</p> <p>Yarn feeder change cam</p> <p>Operation lever for G needle</p> <p>Change lever for knitting needle</p> <p>Yarn feeder change lever</p> <p>Pattern selector cam</p> <p>Screw</p>	<p>37 -1 Knitting needle operation lever</p> <p>37 -2 Washer for knitting needle operation lever</p> <p>Screw for knitting needle operation lever</p> <p>38 Operation lever for G needle</p> <p>38 -1 Washer for G needle operation lever</p> <p>Screw for G needle operation lever</p> <p>39 Pattern selector cam</p> <p>Collar (2 pcs.)</p> <p>40 Yarn feeder change cam</p> <p>Washer for yarn feeder change cam (2 pcs.)</p> <p>Screw for yarn feeder change cam (2 pcs.)</p> <p>41 Reader spring</p> <p>Change lever spring</p>
<ul style="list-style-type: none"> ● Mounting the knitting needle operation lever (37) -1 Put the shaft of the knitting needle operation lever into the G carriage plate and attach the link to the knitting needle operation arm. (37) -2 Fix the knitting needle operation lever with the washer and screw. * Assemble so that the pin of the knitting needle operation lever may locate in the outside groove of the carriage feeding cam. ● Mounting the operation lever for G needle (38) Attach the shaft of the operation lever for G needle into the hole of the G carriage plate and the link to the G needle operation arm with the pin of the lever kept upward. * Assemble so that the square hole of the operation lever for G needle may locate in the shaft. 	<ul style="list-style-type: none"> (38) -1 Fix with the washer and screw for the G needle operation arm. ● Mounting the pattern selector cam (39) Put the change lever for knitting needle into the square hole of the pattern selector cam and place the pins of the knitting needle operation lever assembly and the operation lever for G needle into the grooves and put the two collars onto the fixing holes. ● Mounting the yarn feeder change cam (40) Put the yarn feeder change lever to the yarn feeder change cam and fix it with two washers and screws. (41) Attach the reader spring and the change lever spring for the change lever. 	

Assembling the G carriage

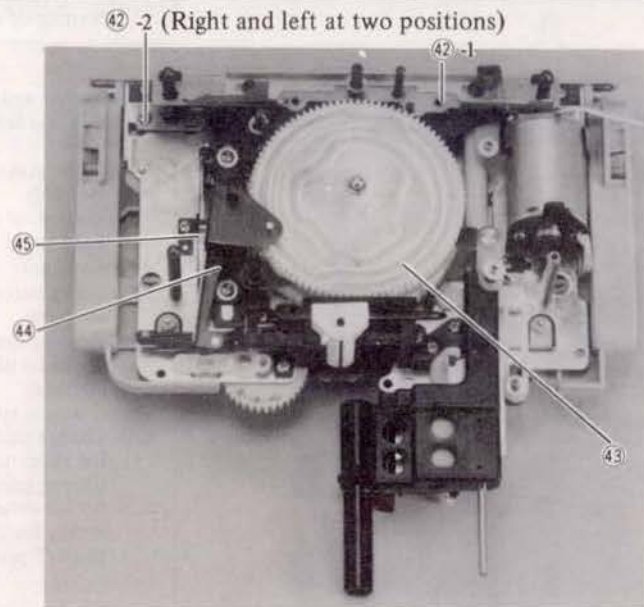

④ Yarn feeder change plate assembly

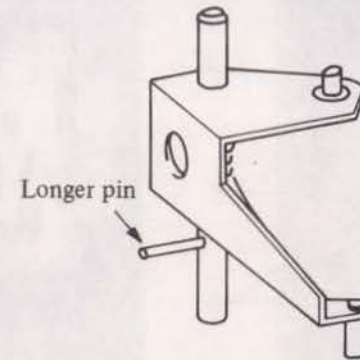

Names of Parts

- ④② -1 Step feeder
- ④② -2 Screw for step feeder (2 pcs.)
- ④③ G needle operation cam
- ④④ Yarn feeder change plate assembly
- ④⑤ Yarn feeder change cam spring
- Screw for yarn feeder Change cam spring

- **Mounting the step feeder**

(42) -1 Mount the step feeder onto the shaft of the G carriage plate without being touch with the lead wire of the DC motor.

- 1 Locate the select lever in the rear of the protruded part of the pattern selector cam.
- 2 Let the shaft for reader and the change lever shaft through the step feeder.
- 3 Put the carriage feeding lever into the cut part of the step feeder.

(42) -2 Fix the step feeder with the right and left two screws.

- **Mounting the G needle operation cam**

(43) Keep the matching mark of the carriage feeding cam upward and match it with the mark of the G needle operation cam located on the periphery to put it in; there is a mark of needle hole size in the inside of the outermost periphery of the cam.

- **Mounting the yarn feeder change plate assembly**

(44) Put the shorter pin of the yarn feeder change plate assembly into the groove of the yarn feeder change cam and put other pins into the yarn feeder holder assembly and the G needle operation cam.

(*Locate the yarn feeder change cam in the rear.)

***Put the pin into the outside groove of the G needle operation cam which permits the rotation.**

- **Mounting the yarn feeder holding cam spring**

(45) Put the longer pin of the yarn feeder change plate assembly into the center square hole of the yarn feeder change cam spring and fix them with the screw by pressing against the pattern selector cam and yarn feeder change cam. (See Fig. on page 21.)

Assembling the G carriage

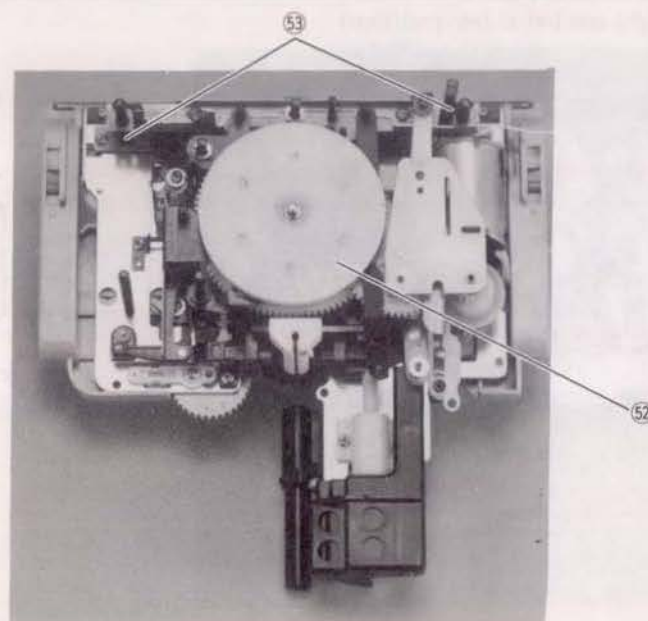
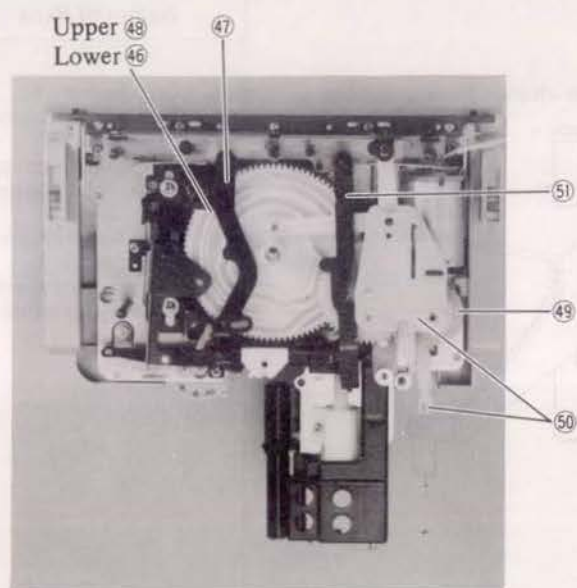

Names of Parts

- ④⑥ Washer and snap ring E ④ for latch presser lever
- ④⑦ Latch presser lever assembly
- ④⑧ Washer for latch presser Snap ring E ④
- ④⑨ Bevel gear
- ④⑩ Row counter connecting plate
- ④⑪ Gear mount
- ④⑫ G needle tilting lever assembly
- ④⑬ G needle tilting cam
- ④⑭ Change plate R for aut-return
- ④⑮ Change plate L for aut-return
- ④⑯ Spring for change plate (2 pcs.)

● Mounting the latch presser lever assembly

- (46) Attach the washer and snap ring E ④ under the groove of the knitting needle operation lever assembly shaft.
- (47) Put the pin of the latch presser lever assembly into the yarn feeder up-down change cam and the latch presser change cam, through the knitting needle operation lever shaft, and into the G needle operation cam and the step feeder.

* Be sure to put the pin into the inside groove of the G needle operation cam which permits tilting.

- (48) Fix with the washer and the snap ring E ④ .
- Mounting the bevel gear
- (49) Put in the bevel gear and fix it with the washer.
- Mounting the row counter connecting plate and the gear mount
- (50) Put the row counter connecting plate to the gear mount assembly and attach to the shaft of the bevel gear while

putting the pin into the feed change link R (step feeder).

- Mounting the G needle tilting lever assembly
- (51) Mount the G needle tilting lever assembly while putting the G needle swing arm and the step feeder together.
- Mounting the G needle tilting cam
- (52) Put the G needle tilting cam by matching the mark. The feed change cam, the G needle tilting cam, and the yarn feeder change cam are arranged in this order from the inside. Set to the proper position.
- Mounting the change plate L for aut-return and the change plate R for aut-return
- (53) Mount the change plate R (black) and L (white) for aut-return and put the springs to the change plates.

Assembling the G carriage

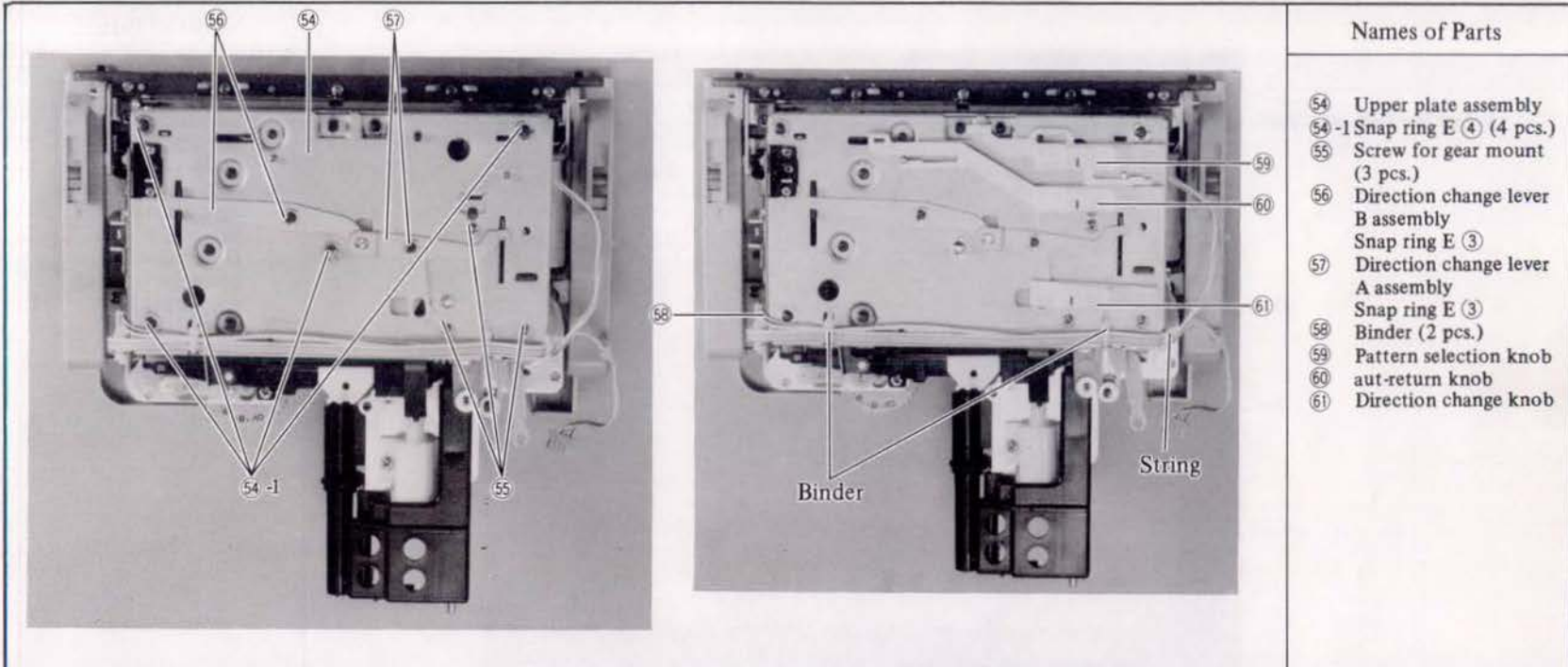

Names of Parts

- ⑤④ Upper plate assembly
- ⑤④-1 Snap ring E ④ (4 pcs.)
- ⑤⑤ Screw for gear mount (3 pcs.)
- ⑤⑥ Direction change lever B assembly
Snap ring E ③
- ⑤⑦ Direction change lever A assembly
Snap ring E ③
- ⑤⑧ Binder (2 pcs.)
- ⑤⑨ Pattern selection knob
- ⑥⑦ aut-return knob
- ⑥① Direction change knob

- **Mounting the upper plate assembly**

(54) Mount the upper plate assembly onto the shafts.

***Check to be sure that the bevel gear can be rotated clockwise by hand.**

(54)-1 Fix the plate with four snap rings E ④ .

(55) Fix the gear mount with the three screws.

- **Mounting the direction change lever B assembly**

(56) Put the direction change lever B assembly into the yarn feeder change cam with the pin kept upward and fix it with snap ring E ③ .

- **Mounting the direction change lever A assembly**

(57) Put the direction change lever A assembly into the row counter connecting plate fit to the pin of the direction change lever B assembly, and fix with snap ring E ③ .

- **Mounting the connector of the DC motor (when the binder is cut)**

(58) When detaching the control board, fix the lead wire to the upper plate assembly with the two binders and the one string.

- **Mounting the stop knob**

(59) Place the pattern selection knob so that the shaft of the selection lever may be pressed with it.

- **Mounting the aut-return knob**

(60) Place the aut-return knob so that the lever for aut-return of the step feeder may be located in the square hole of the knob.

- **Mounting the direction change knob**

(61) Place the direction change knob so that the boss may be located in the hole of the direction change lever A assembly.

Assembling the G carriage

⑥② Let the lead wire pass.

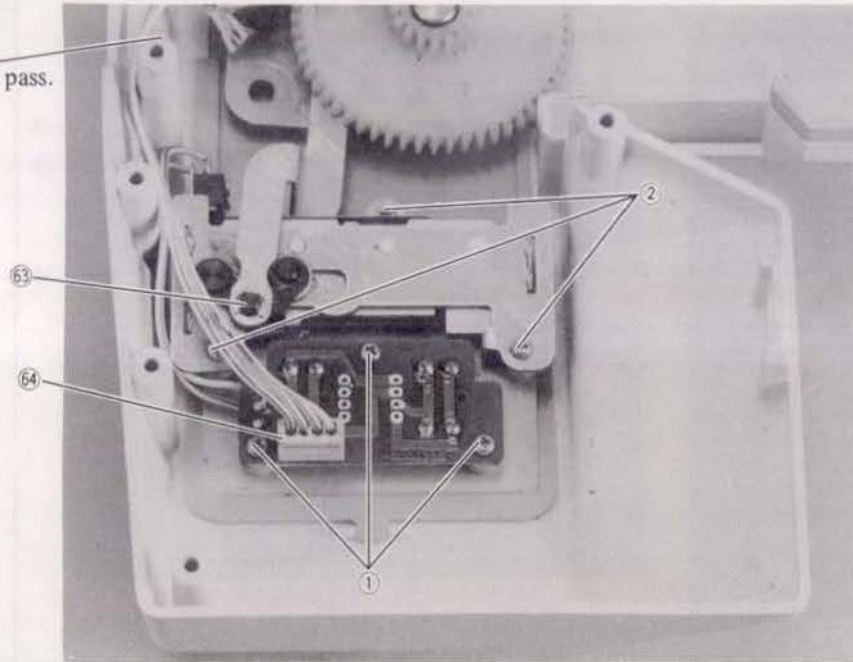

Names of Parts

- ① Switch key
Switch spring (2 pcs. for each)
Screw (3 pcs.)
- ② Row counter window,
Row counter
Screw (3 pcs.)
- ③ G carriage cover
Screw for G carriage foot (2 pcs.)
- ④ Snap ring E
- ⑤ Connector

● Mounting the G carriage cover

- (1) Put the switch springs into the switch keys from the rear side of the G carriage cover, place them properly, put the switch board over them, and fix it with three screws.
- (2) Fix the row counter window and the row counter assembly with three screw.

***The switch key functions to start (green) and to stop (red).**

Disassembly: 1. Loosen the three screws shown in Fig. ② to detach the row counter and the row counter window.

2. Loosen the three screws shown in Fig. ① to detach the switch plate, the switch spring, and the switch key.

● Mounting the G carriage cover

- (62) Let the lead wire of the control board between the carriage cover and the shaft to mount the G carriage cover and put the G carriage cover over it. And fix with the two screws for G carriage foot.
- (63) Fix the row counter connecting plate to the center pin of the row counter with the snap ring E ③ .
- (64) Attach the connector of the control board to the switch board.

***Take care not to let the lead wire get contact with the row counter connecting plate and the bevel gear.**

Assembling the G carriage

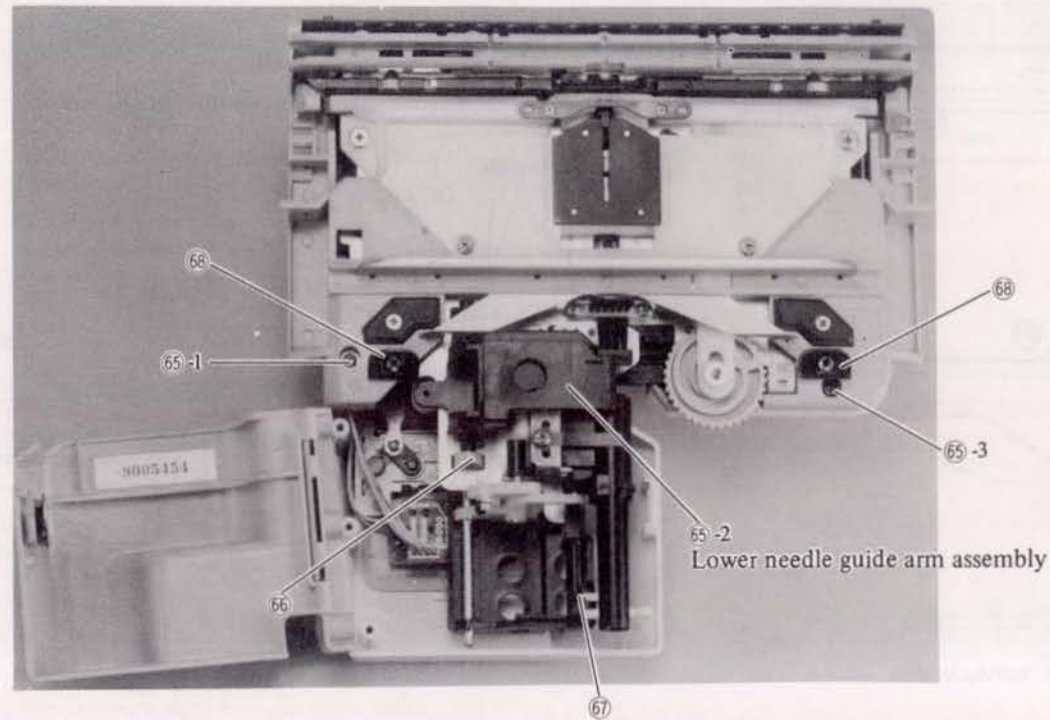

Names of Parts

- ⑥⑤ Screw for G carriage
(3 pcs.)
- ⑥⑥ Needle guide arm
- ⑥⑦ G needle
- ⑥⑧ Rubber wheel
Washer for rubber
wheel
Screw for rubber wheel
(2 pcs. respectively)

- (65) Fix the G carriage cover with three screws: 65-1, 65-2 & 65-3)
- **Mounting the needle guide arm**
(66) Put the needle guide arm assembly to the boss of the pitch adjuster.
- **Mounting the G needle**
(67) Put the G needle into the G socket for G needle and attach

the lever of the G needle operation arm assembly to the G needle.

- **Mounting the rubber wheel**
(68) Attach the right and left rubber wheels with the screws and washers.
***Keep the protruded part inward.**

Assembling the G carriage

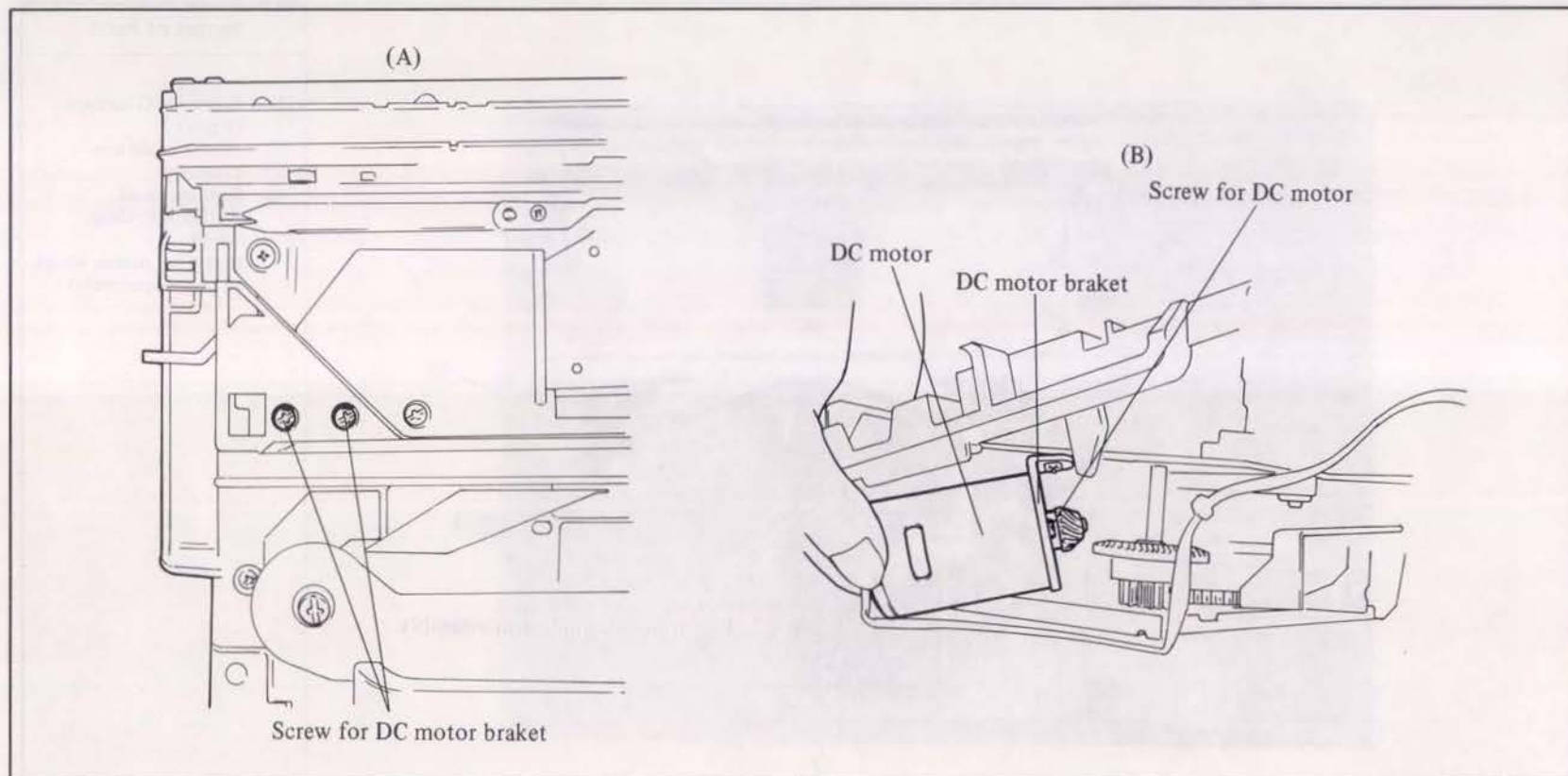

● How to replace the DC motor only

- (1) Disassembling the G carriage by referring to the page 6 item 1 to page 7 item 14.
- (2) Turn over the carriage and remove the two screws for the DC motor bracket. (A)
- (3) Lift the G carriage foot and remove the DC motor with the DC motor bracket. (B)
- (4) Remove the two screws for the DC motor.
- (5) Replace the DC motor with new one. Attach the two screws for the DC motor to the DC motor bracket.
- (6) Lift the G carriage foot and put the DC motor with the DC motor bracket while the gear in the DC motor bites the level gear.
- (7) Fix the DC motor bracket with the two screws for the DC motor bracket.
- (8) Connect the connector of the DC motor with the control board.
- (9) Assembling the G carriage by referring page 24 item 58 to page 26 item 68.

6. HOW TO ADJUST THE G CARRIAGE

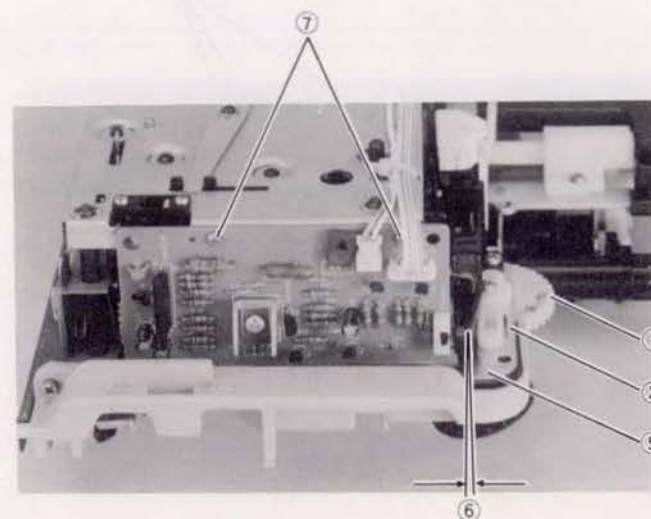
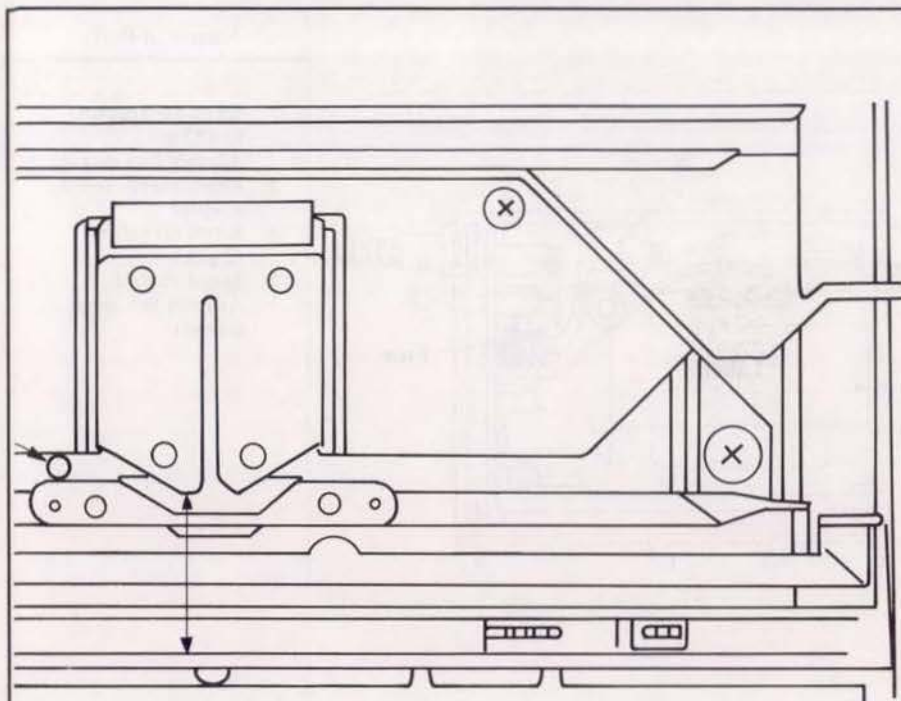

- **Adjusting the yarn take-up of the stitch cam**

- (1) Set the stitch dial to ⑤ .
- (2) Adjust the stitch dial lever by moving it longitudinally.
- (3) Dimension between the rear end of the G carriage rear groove (to fit the rail) and stitch cam guide plate
 KG-89 33 m/m
 KG-88 34.1 m/m
- (4) Fix with the stitch dial screw.

- **Adjusting the motor control board**

- (5) Rotate the bevel gear clockwise and move the yarn feeder holder near the control board.
- (6) Push the yarn feeder holder forward and keep it as it is by releasing hand from it.
- (7) Place the control board near the yarn feeder holder so that the board may not get contact with the holder and fix it with two screws for control board.

Note: The yarn feeder holder should not get contact with the control board.

7. DISASSEMBLING AND ASSEMBLING THE ADAPTOR

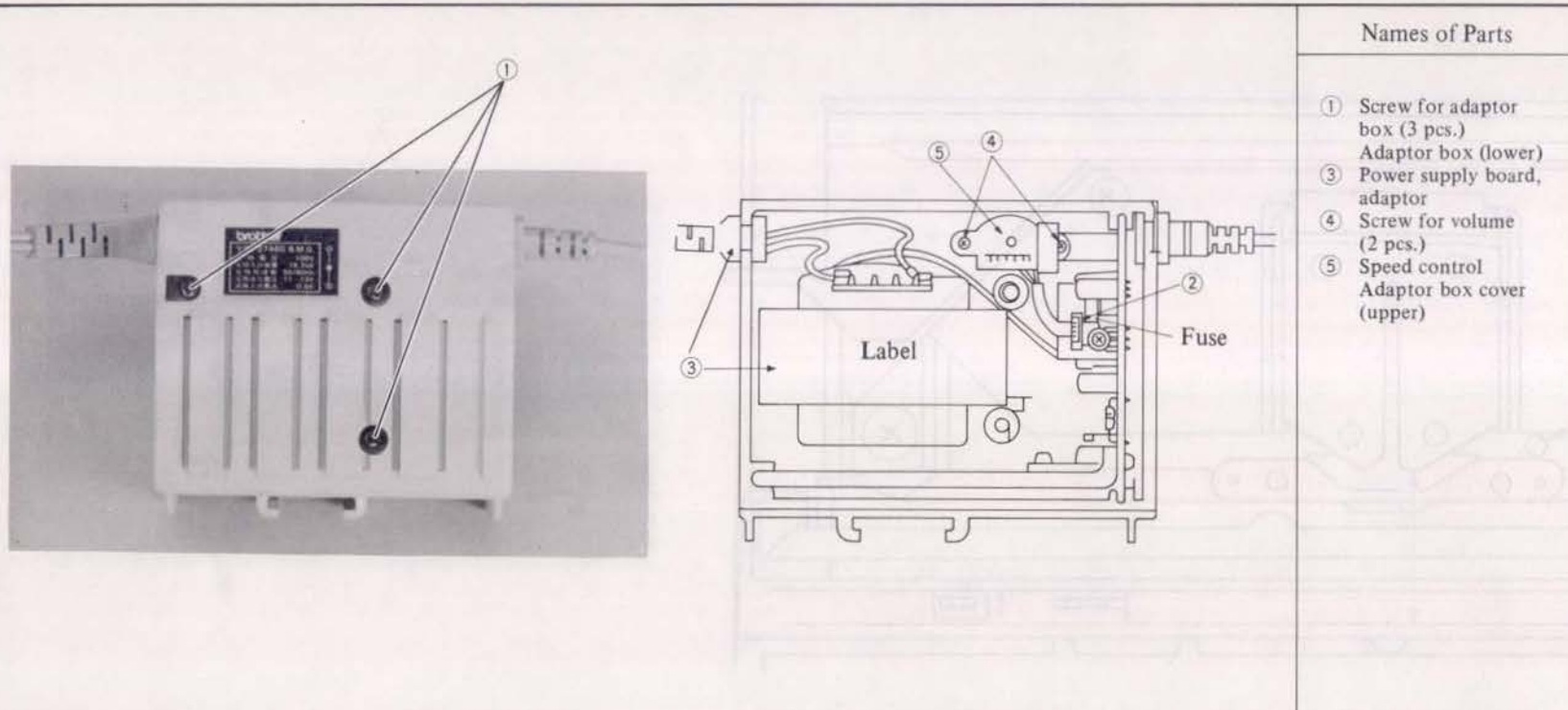

• Disassembling the adaptor

- (1) Loosen the three screws for adaptor box and remove the lower adaptor box.
- (2) Detach the connector of the speed control board from the power board.
- (3) Remove the bush of the cord and detach the power board and the adaptor upward.
- (4) Loosen the two screws to remove the speed control board.
- (5) Remove the speed control knob.

• Assembling the adaptor

- (5) Put the speed control knob to the speed control board.
- (4) Fix the speed control board onto the upper adaptor cover with the two screws.
- (3) Put in the adaptor and the power board together and attach the bush of the cord.
- (2) Attach the connector of the speed control board to the power board.
- (1) Attach the lower adaptor cover and fix it with the three screws.

8. DISASSEMBLING AND ASSEMBLING THE SENSOR FOR YARN BREAKAGE

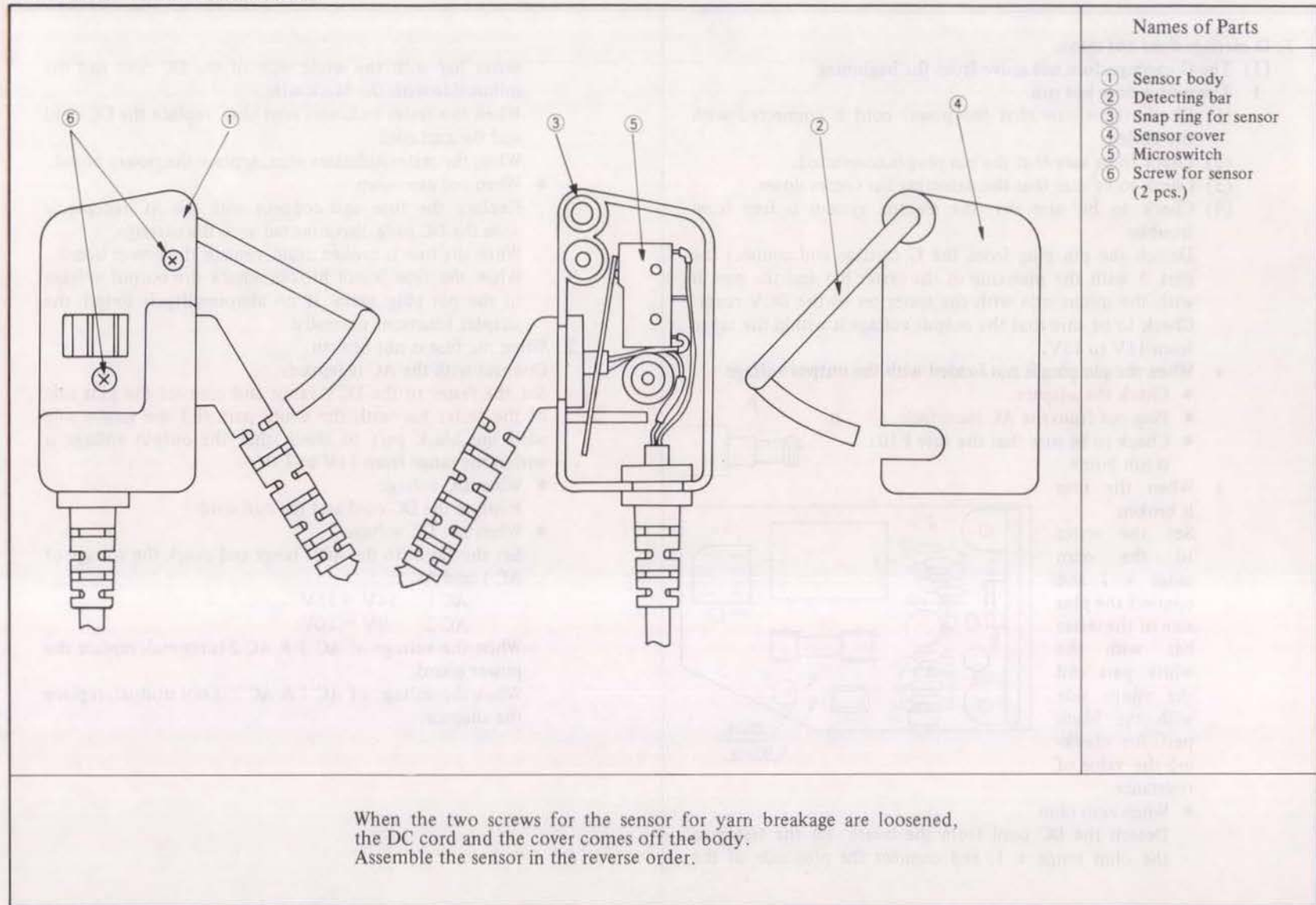

9. TROUBLE SHOOTING

1. G carriage does not move.

(1) The G carriage does not move from the beginning.

1 The motor does not run.

- (1) Check to be sure that the power cord is connected with the outlet.
- (2) Check to be sure that the pin plug is connected.
- (3) Check to be sure that the detecting bar comes down.
- (4) Check to be sure that the electric system is free from troubles.

Detach the pin plug from the G carriage and connect the part A with the plus side of the tester bar and the part B with the minus side with the tester set to the DCV range. Check to be sure that the output voltage is within the range from 11V to 13V.

a When the pin plug is not loaded with the output voltage

- Check the adaptor.
- Plug out from the AC receptacle.
- Check to be sure that the fuse F101 is not burnt.

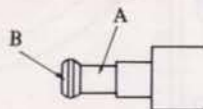

1 When the fuse is broken

Set the tester to the ohm range x 1 and connect the plus side of the tester bar with the white part and the minus side with the black part for checking the value of resistance.

- When zero ohm

Detach the DC cord from the board, set the tester to the ohm range x 1, and connect the plus side of the

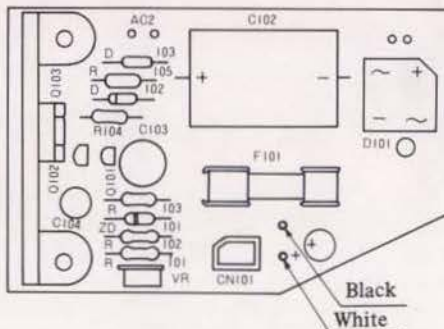

tester bar with the white wire of the DC cord and the minus side with the black wire.

When the tester indicates zero ohm, replace the DC cord and the curl cord.

When the tester indicates ohm, replace the power board.

- When not zero ohm

Replace the fuse and connect with the AC receptacle with the DC plug disconnected with the carriage.

When the fuse is broken again, replace the power board.

When the fuse is not broken, check the output voltage of the pin plug again. If no abnormality is found, the adapter functions normally.

2 When the fuse is not broken

Connect with the AC receptacle.

Set the tester to the DCV range and connect the plus side of the tester bar with the white part and the minus side with the black part to check that the output voltage is within the range from 11V to 13V.

- When DC voltage

Replace the DC cord and the curl cord.

- When not DC voltage

Set the tester to the ACV range and check the voltage of AC 1 and AC 2;

AC 1 14V ~ 15V

AC 2 9V ~ 10V

When the voltage of AC 1 & AC 2 is normal, replace the power board.

When the voltage of AC 1 & AC 2 is not normal, replace the adaptor.

b When the pin plug is loaded with the output voltage

1 Check the DC motor assembly.

Detach the connector of the motor from the motor control board. Set the tester to the ohm range x 1 and perform the zero adjustment thoroughly.

Connect the tester bars with the both ends of the connector and check the value of the motor resistance.

When the tester indicates around two ohm, the motor is in the normal condition.

When indicating other values, replace the DC motor.

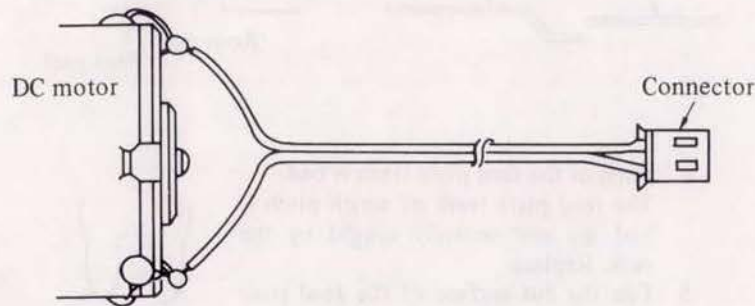

2 Check the switch board

(Set the row counter to the numerals other than "000.")

How to check the stop switch

Set the tester to the ohm range x 1 and connect the tester bars with the both ends of A.

The value of resistance is normally ∞ . When zero ohm, replace the switch board, which is out of order.

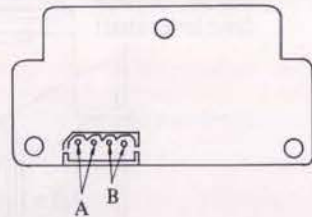

The tester indicates zero ohm when the stop switch is pressed. When not indicating zero ohm, replace the switch board.

How to check the start switch

Set the tester to the ohm range x 1 and connect the tester bars with the both ends of B.

The tester normally indicates ∞ . When zero ohm, replace the switch board, which is out of order.

The tester indicates zero ohm when the start switch is pressed. When not indicating zero ohm, replace the switch board, which is out of order.

3 When no abnormality is found with the adaptor, the DC motor assembly, and the switch board, replace the motor control board.

2 The motor tries to run but the mechanism does not work.

- (1) Check to be sure that the counter is not set to "000."
- (2) Check to be sure that each knob is located inbetween.
- (3) Check to be sure that the pin comes off the cam groove.

- Check whether the pin of the yarn feeder change plate assembly is in the both cam grooves.
- Check whether the needle operation lever assembly and the operation lever for G needle assembly come off the cam groove.
- Check whether the shaft of the casting off lever comes off the hole of the upper plate assembly.
- Check whether the shafts of the change lever and the reader for needle selection come off the guide holes.
- Check whether the link for pitch adjuster comes off; fix with the washer and the tapping screw so that it may not come off.

Disassemble and assemble the G carriage while checking these points and checking to be sure that each mechanism works smoothly.

(2) The G carriage stops in the middle of movement.

- 1 The G needle does not move due to knots, stitch floats, etc.
- 2 The yarn is entangled with the yarn take-up device.
- 3 The G point cam (of various types) is floated and is not located at the proper position.
- 4 The needle of the machine comes forward the position B and gets contact with the G carriage.

Check these points.

When the G carriage stops in the middle of the fabric, move the G carriage out of the fabric according to the manual (page 39 ~ 40). When the hook of the G needle is caught by the yarn feeder and is not pulled out, separate the yarn feeder and the arm for socket where the G needle locates by force to pull out the G needle.

(3) The motor runs but the carriage does not move.

- 1 The G carriage feeding lever shaft is loosely assembled.
Turn over the G carriage. If the shaft shown in the figure moves when the carriage is moved, the assembly is found loose. In this case, replace the G carriage plate assembly.
- 2 The feed plate does not move smoothly and laterally. (See the page 34.)
 - The feed plate is aligned.
 - The direction change lever spring becomes weak.
 - The shaft of the casting-off lever assembly comes off the hole of the upper plate assembly.
 Replace or repair by checking these points.

- 3 The height and width of the extension rail is improper.
Adjust so that the needle bed may be parallel to the extension rail in the direction of the height and the width of the root part may be equal to the one of the bent part when installing the extension rail.

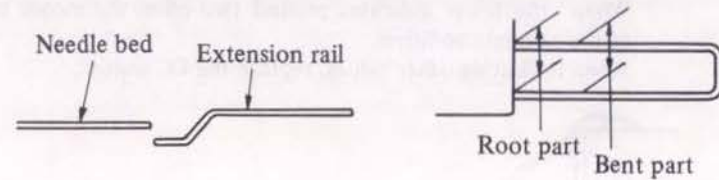

- 4 Pitch of the feed plate teeth is bad.
The feed plate teeth of which pitch is bad are not securely caught by the rack. Replace.
- 5 File the cut surface of the feed positioning plate teeth smooth when not smooth.

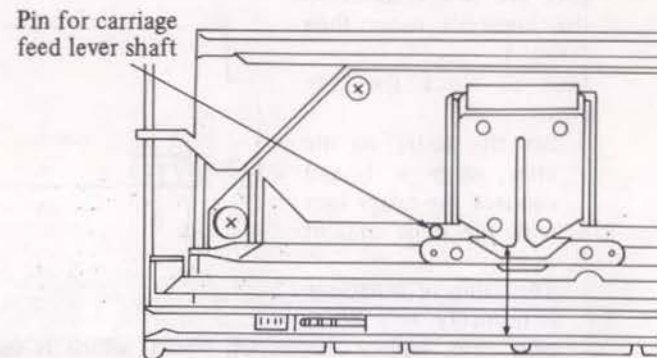
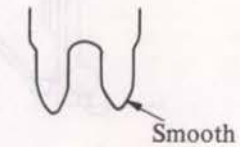

3 Lateral movement of feed plate

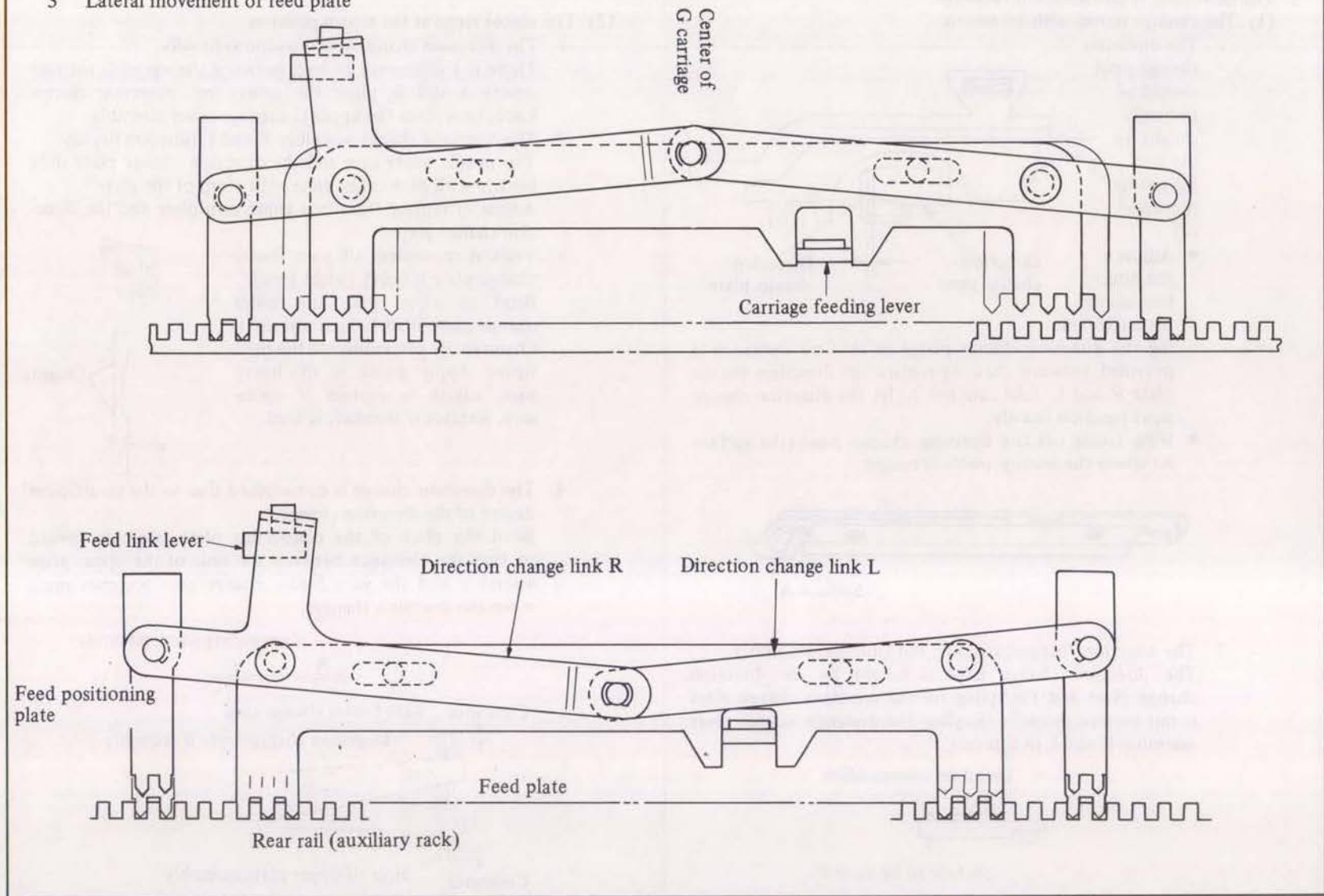

2. The automatic return does not function.

(1) The carriage moves without return.

1 The direction change pawl should be normally caught by the resting needle; it comes off.

- Adjust the direction change plate (by bending the direction change plate) so that no clearance is provided between them or replace the direction change plate R and L; take care not to let the direction change pawl function heavily.
- Wipe grease off the direction change pawl (the surface A) where the resting needle is caught.

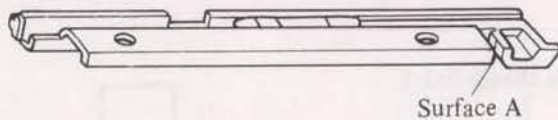
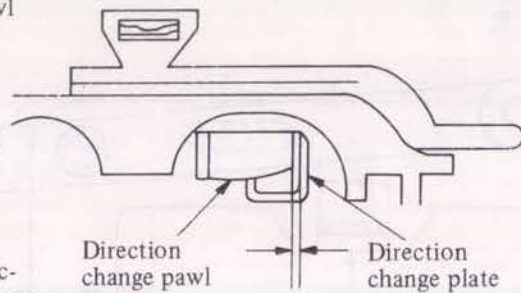

2 The direction change pawl does not function smoothly. The direction change pawl is caught by the direction change plate and the spring for the direction change plate is not located properly. Replace the direction change plate assembly R and L in this case.

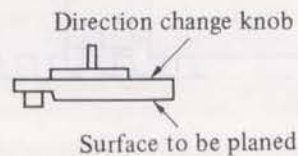

(2) The motor stops at the return position.

1 The direction change knob functions heavily. There is a difference in level between the upper G carriage covers A and B; plane the cover, the direction change knob, or replace the upper G carriage cover assembly.

2 The direction change assembly R and L function heavily. The needle guide cam and the direction change plate slide heavily with each other due to the warp of the plate. Adjust or replace the stitch guide cam plate and the direction change plate.

3 Vertical movement of yarn feeder change plate is heavy (when feed). Bend to adjust the yarn feeder change plate if its bent is not right. Chamfer the parts shown in the right figure. Apply grease to the heavy part, adjust or replace if necessary. Replace if the shaft is bent.

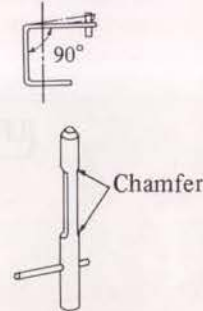

4 The direction change is not secured due to the insufficient degree of the direction change. Bend the plate of the connecting plate assembly inward so that the clearance between the hole of the upper plate assembly and the yarn feeder change cam becomes small when the direction changes.

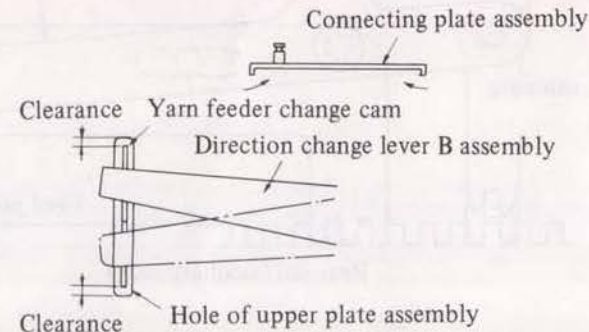

- 5 The row counter functions heavily.
Adjust the longitudinal position of the row counter when the numeral rotor gets contact with the hole of the upper G carriage cover assembly and the counter functions heavily. If the row counter connecting plate is bent, adjust it to flat.
Apply oil or grease when the sliding part is out of oil and the counter functions heavily. If it still functions heavily, replace.
- 6 The height and width of the extension rail are improper.
See the page 33.

(3) The carriage returns at any position where it does not normally returns.

- 1 The needle comes off at the position A
Attach the needle.
- 2 The needle of the position A is among needles where fabric hangs.
Knitting by automatic return is impossible.
- 3 The needle of the position A is sometimes lowered.
Replace the needle or the needle retaining spring.

3. Dropping stitches

If the stitch drops, knit with the new G needle. If it still drops, check the following points.

(1) The G needle is out of order.

Check to be sure that the latch normally operates. The latch is out of order because oil is short, the latch is bent, and/or the spring is damaged. Supply oil, repair, or replace if necessary.

The right figure shows the dimension necessary for the G needle. Measure it to check whether it is satisfied or not. Check to be sure that the needle is not bent. The latch should operate as smoothly as

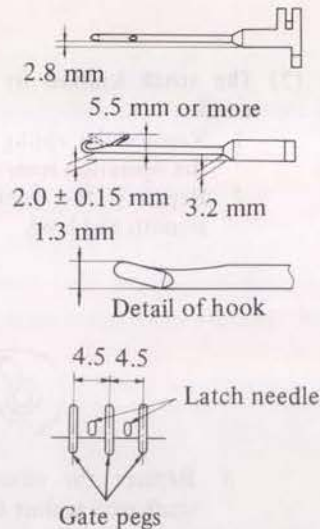

possible and it should be opened 5.5 mm or more by the spring.

Adjust or replace the G needle, which is out of order, as shown in the left figure.

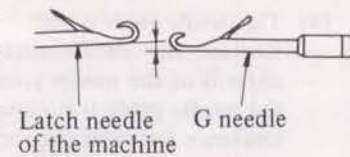

(2) Replace the KH needle if the latch is out of order and the latch needle is bent.

Check to be sure that the KH needle is located in the middle of the teeth of the gate pegs. And check the longitudinal, vertical, and lateral adjustments of gate pegs. Bend to adjust or replace the gate pegs if necessary. If the needle presser bar assembly is damaged, replace it with new one.

With regard to the model KG-88, check to be sure that the needle position indicator of the model KH-881 is not warped and the needle does not float. Replace the warped needle position indicator.

(3) The tilting of the G needle is improper. (The abnormal sound might be generated.)

(The G needle is caught by the gate pegs if the G needle tilts too much and the stitch drops if it does too little.) As shown in the right figure, the upper plate assembly and the G needle tilting lever assembly are parallel and the tilting degree of the G needle becomes zero. Turn to adjust the G needle tilting lever in the proper direction so that the tilting degree of the G needle may become zero.

Replace if the socket for G needle does not tilt in the hole of the arm for socket smoothly.

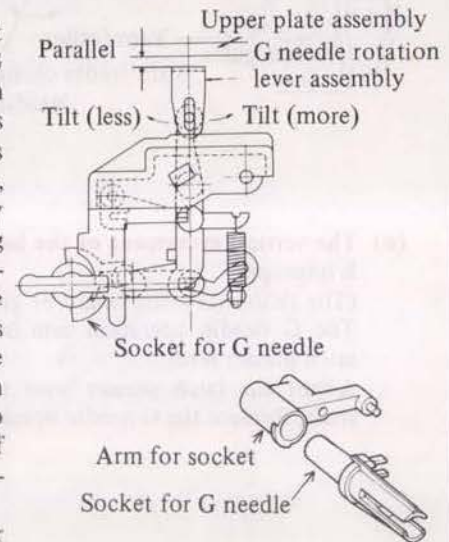

(4) The needle guide is bad.

Replace the needle guide arm if the angle B of the needle guide is not right, the needle guide is broken, and there is clearance between the surface A of the needle guide and the G needle (when placed the G needle to the right side).

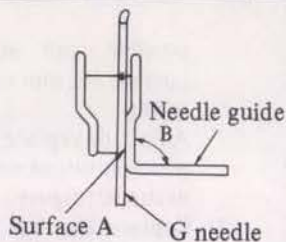

(5) The moving degree of the yarn feeder is improper.

(The abnormal sound might be generated.)

Adjust the right movement of the yarn feeder when the G carriage moves to the left as shown in the following figure. Bend and adjust the pin B of the yarn feeder change plate so that the following dimension may be obtained.

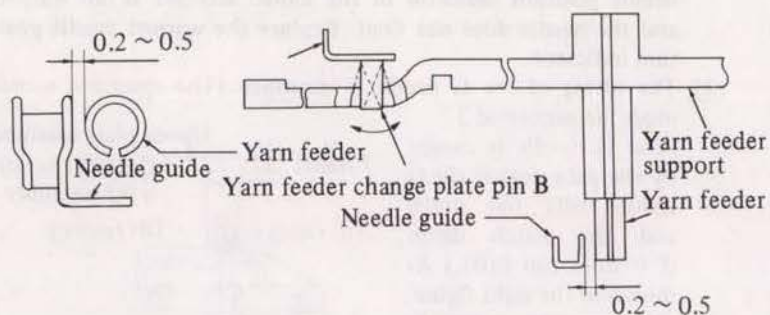

(6) The vertical movement of the latch presser and the yarn feeder is improper.

(The abnormal sound might be generated.)

The G needle operation cam is damaged by the warp of the latch presser lever.

Adjust the latch presser lever so that it may be right to the shaft. Replace the G needle operation cam.

4. The wrong needle selection is performed.

Check to be sure that the wrong needle selection cannot be found with the K carriage. If the wrong needle selection is found, adjust by referring to the service manual of the machine.

(1) The stitch knitted by KH needle (purl) becomes the stitch by G needle (Plain).

- 1 When the hole where the reader for needle selection of the feed base assembly is located gets contact with the shaft of the contact assembly, make the hole of the feed base assembly bigger.
- 2 When the reader for needle selection does not move smoothly and vertically, replace the upper plate assembly or apply grease; when no spring is attached.
- 3 Reassemble if the reader for needle selection rubber is not put into the shaft of the contact assembly and is located under the operation lever assembly.
- 4 Replace the spring for retainer if damaged.

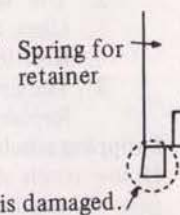

(2) The stitch knitted by G needle becomes the stitch by KH needle.

- 1 Replace the spring for reader if it is not smoothly put to the operation lever assembly.
- 2 Repair if the lever of the change lever for stitch is not smooth and level.

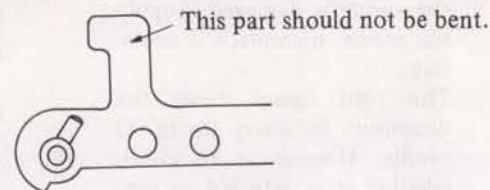

- 3 Replace the change lever for stitch if it rotates at the shaft part against the lever.

5. The stop key does not function and the row counter does not stop at "000."

(1) The distance between the sensor and the magnet is too far.

Turn the bevel gear Z50 clockwise by hand and adjust the control board by checking the following three points when the sensor and the magnet come nearest with each other. (page 28)

- 1 Longitudinal position
See the adjustment on the page 28.
- 2 Vertical position
Make the hole of the control board bigger and adjust.
- 3 Lateral position
Change the bent angle of the upper plate assembly where the control board is mounted.

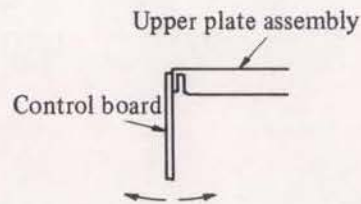

(2) The switch of the row counter assembly does not change over smoothly.

(The row counter does not stop at "000.")

Check to be sure that the row counter is set to "000." Set the tester to the ohm range x 1 and connect the tester bars with the both ends of A. The tester should indicate zero ohm at this time. Replace the row counter assembly if not indicating zero ohm.

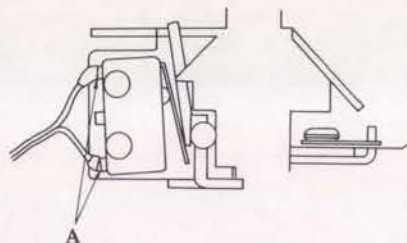

(3) The switch board is out of order.

- 1 If the stop key does not function, refer to the section 2 on the page 32; the checking method of the stop switch.

- 2 If the G carriage does not stop at "000," set the row counter to "000," set the tester to the ohm range x 1, and connect the tester bars with the both ends of A. If the tester indicates zero ohm, the control board is out of order. If not indicating zero ohm, the switch board is out of order.

6. The sensor for yarn breakage does not work.

If the yarn is cut before the sensor for yarn breakage, it does not sometimes work. If the yarn is cut after the sensor for yarn breakage, it securely works.

- (1) Push the lever A of the sensor for yarn breakage to turn on the microswitch while connecting the tester with the pin plug. If the tester indicates zero volt, the sensor for yarn breakage is found normal. In this case, replace the motor control board. If the tester does not indicate zero volt, replace the sensor for yarn breakage.

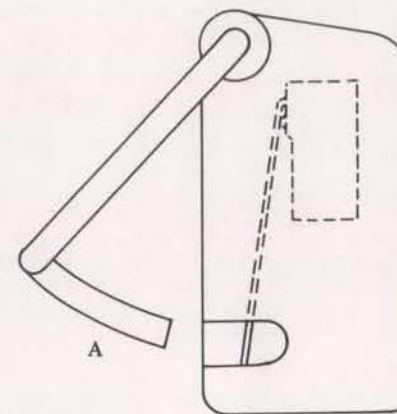

7. Any abnormal sound is generated.

- (1) Oil gets short between the bevel gear Z50 and the washer. Replace the bevel gear Z50 and apply grease.
- (2) The latch of the G needle gets contact with the gate pegs. See the sections 3 (2) and 3 (3).
- (3) The yarn feeder gets contact with the needle guide. See the section 3 (5).

