

SERVICE MANUAL FOR KNITTING MACHINE AND RIBBING ATTACHMENT

brother[®]

MODEL KH-864

MODEL KH-868

MODEL KH-894

MODEL KR-830

MODEL KR-838

MODEL KR-850

MODEL KL-116

CONTENTS

1. PRODUCT SPECIFICATIONS OF KH-864/KH-868/KH-894	1	15. ASSEMBLING THE NEEDLE SELECTOR UNIT	42
1.1 PRODUCT SPECIFICATIONS OF KH-864/KH-868	1	16. ASSEMBLING THE NEEDLE SELECTOR PLATE HOLDER	44
1.2 PRODUCT SPECIFICATIONS OF KH-894	1	17. ASSEMBLING THE NEEDLE SELECTOR UNIT IN THE NEEDLE PLATE HOLDER	45
2. OPERATION SEQUENCE OF NEEDLE SELECTION BY PUNCHED CARD	2	18. ASSEMBLING THE NEEDLE SELECTOR PLATE HOLDER IN THE BODY	46
3. QUICK TROUBLESHOOTING CHART	3	19. INSPECTION OF NEEDLE SELECTOR FUNCTIONS	49
4. KH-864, 868, 894 NEEDLE SELECTION MECHANISM	5	20. ADJUST THE MACHINE BODY	50
5. SINGLE MOTIF MECHANISM	6	21. ADJUST L CARRIAGE	62
6. END NEEDLE SELECTION MECHANISM	7	22. RIBBING ATTACHMENT KR-830, 838	65
7. CAM BUTTON AUTO RESET MECHANISM	9	23. RIBBING ATTACHMENT KR-850	67
8. DISASSEMBLY AND ASSEMBLY OF K CARRIAGE (KH-864, 868)	10	24. KNIT LEADER	70
8.1 Disassembling the K carriage	10		
8.2 Assembling the K carriage	15		
9. DISASSEMBLY AND ASSEMBLY OF K CARRIAGE (KH-894)	20		
9.1 Disassembling the K carriage	20		
9.2 Assembling the K carriage	25		
10. CHECKING THE CARRIAGE FUNCTION	30		
10.1 KH-864, 868 CHECKING THE CARRIAGE FUNCTION -1- ...	30		
10.2 KH-864, 868 CHECKING THE CARRIAGE FUNCTION -2- ...	31		
10.3 KH-894 CHECKING THE CARRIAGE FUNCTION -1-	32		
10.4 KH-894 CHECKING THE CARRIAGE FUNCTION -2-	33		
11. ADJUST THE CARRIAGE	34		
12. DISASSEMBLING THE BED	36		
13. DISASSEMBLING THE NEEDLE SELECTOR PLATE HOLDER ...	39		
14. DISASSEMBLING THE NEEDLE SELECTOR UNIT	41		

1. PRODUCT SPECIFICATIONS OF KH-864/KH-868/KH-894

1.1 PRODUCT SPECIFICATIONS OF KH-864/KH-868

Pitch of stitches	4.5 mm
No. of needles	200 needles
No. of selected needles	24 needles
Needle selection	punch card
Patterning function	Fair-isle pattern, Skip pattern, Tuck pattern, Weaving pattern, Plating Yarn knitting, Plating Tuck pattern, Lace pattern, Fine lace pattern
Patterning variation	Double length, Single motif
End needle selection mechanism	automatic
Knit leader	available optionally (KL-116)
Weight	14 kg
Size	L1059 mm x W216 mm x H97 mm
Color	White
Needle bed material	Tempered steel can be installed
KR-KHC-KRC usage	KR-850, 830, 838, KHC-820, KRC-830, 900 T carriages may be used (KA-8300) Intarsia carriage may be used (KA-8200) Linker may be used (KA-8310)
Auto carriages	KG89 may be used

1.2 PRODUCT SPECIFICATIONS OF KH-894

Pitch of stitches	4.5 mm
No. of needles	200 needles
No. of selected needles	24 needles
Needle selection	punch card
Patterning function	Fair-isle pattern, Thread-lace pattern, Skip pattern, Tuck pattern, Weaving pattern, Plating Yarn knitting, Plating Tuck pattern, Lace pattern, Fine lace pattern
Patterning variation	Double length, Single motif
End needle selection mechanism	automatic
Knit leader	available optionally (KL-116)
Weight	14 kg
Size	L1059 mm x W216 mm x H97 mm
Color	White
Needle bed material	Tempered steel can be installed
KR-KHC-KRC usage	KR-850, 830, 838, KHC-820, KRC-830, 900 T carriages may be used (KA-8300) Intarsia carriage may be used (KA-8200) Linker may be used (KA-8310)
Auto carriages	KG89 may be used

2. OPERATION SEQUENCE OF NEEDLE SELECTION BY PUNCHED CARD

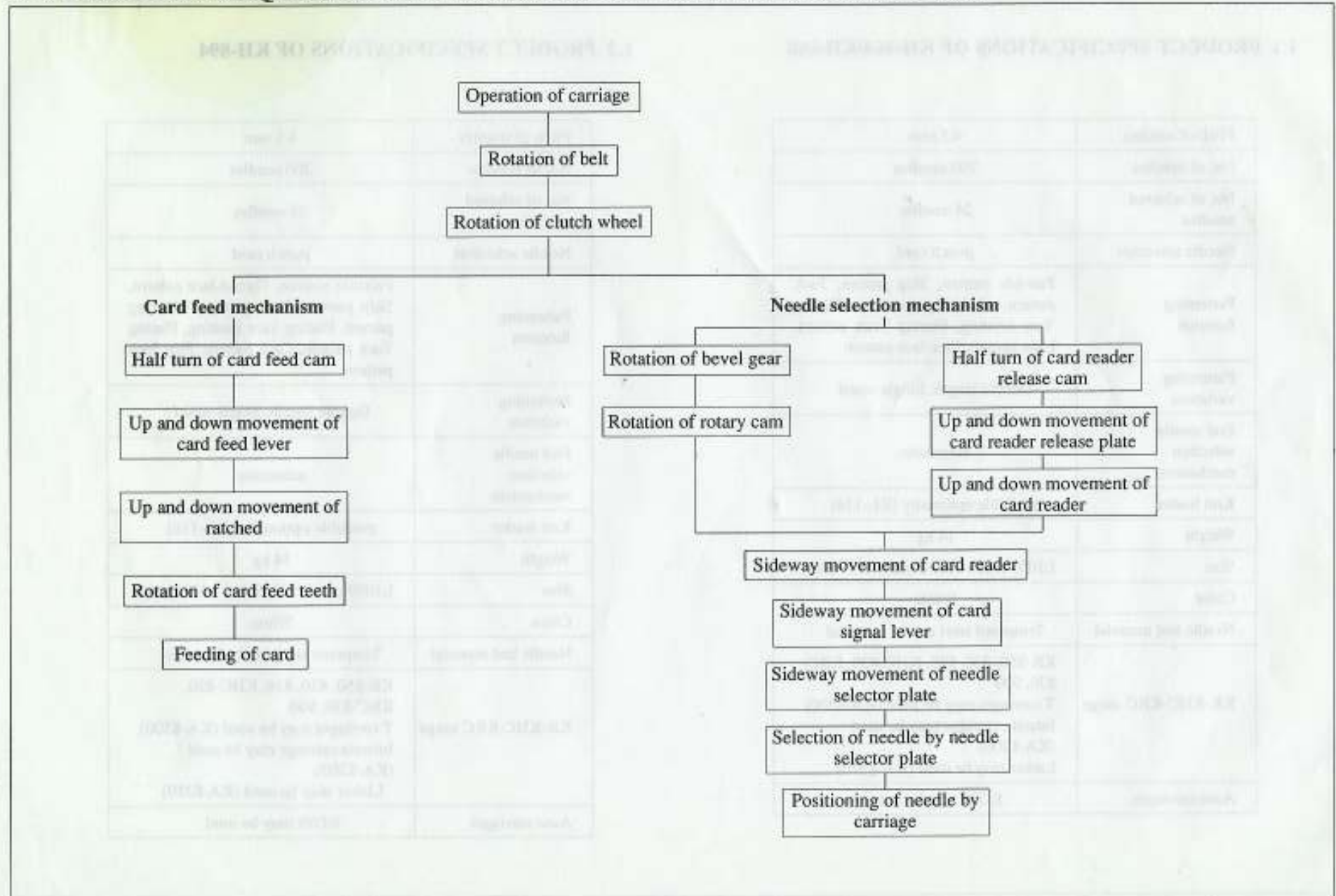

3. QUICK TROUBLESHOOTING CHART

	Trouble	Origin	Remedy	Notes
K carriage	K carriage does not move easily	1. Carriage cam sliding. Part is out of oil	1. Oil the butt of the needle and the stitch cam	
		2. Needle bed sliding. Part is out of oil	2. Oil front and rear rails of body and carriage	
		3. The sinker plate and gate peg are in contact	3. Correct sinker plate front-rear adjustment	See P. 34
		4. The sinker plate is lifting the knitting needle	4. Correct vertical adjustment of sinker plate	See P. 34
		5. The gage is too tight	5. Loosen knitting gage	
Knitting	Floating stitches. Stitches get tucked.	1. Too much gap between sinker plate and gate peg	1. Correct front-rear adjustment of sinker plate	See P. 34
		2. Too much gap between sinker plate and needle	2. Correct vertical adjustment of sinker plate	See P. 34
		3. Needle latch not functioning properly	3. Change needle	
		4. The gage is too tight	4. Loosen knitting gage	
	Stitches irregular (uneven) Lateral stripe is produced occasionally	1. Uneven speed in carriage operation	1. Make carriage operation speed constant.	
		2. Poor yarn feed	2. Loosen spring tension of the yarn tension disk	
Knitting gage of the right needle bed and that of the left is different	1. Attachment of needle bed comb uneven left to right	1. Adjust the needle bed comb position even left to right	See P. 50	
The carriage gets stuck while knitting	1. The needle bed is damaged	1. Repair needle bed		
	2. The butt of the needle is damaged	2. Replace needle		
L carriage	The L carriage gets stuck midway and will not move	1. The gage is too tight	1. Loosen knitting gage	
		2. The L carriage was operated with pulling it up.	2. Operate carriage correctly	
		3. The spring plate is damaged	3. Replace spring plate	See P. 62
	Comb teeth catch stitches	1. The gage is too loose	1. Tighten knitting gage	
		2. Yarn feeds poorly	2. Use wax on yarn tension wax stand	
		3. Speed of operation is too fast	3. Operate in proper speed	
		4. Gate peg bent	4. Adjust the gate peg	
	Stitches are dropped	1. Poor latch needle operation	1. Replace the needle	
		2. Gate peg bent	2. Adjust gate peg	
		3. Needle transfer plate position improper	3. Correct right-left adjustment of needle transfer plate	See P. 62
4. Main cam improperly positioned		4. Correct front-rear adjustment of Main cam	See P. 62	
5. Spring plate position improper		5. Correct horizontal adjustment of spring plate	See P. 62	
6. Sinker plate bent		6. Correct bend in sinker plate	See P. 62	
End needle is selected	1. End needle selection change cam for L is not properly set	1. Set end needle selection change cam for L properly		
	2. End needle selection cam is bad	2. Replace end needle selection cam		

	Trouble	Origin	Remedy	Notes	
Needle selection	The same needle does not come out	1. The butt or shank of needle bent	1. Replace needle		
		2. Left-right measurement problem between rotary cam lever and rotary cam	2. Correct right-left adjustment of rotary cam (needle selection mechanism)	See P. 53	
	Unnecessary needles come out at 8 cycles	1. There is grease between the needle selector plates.	1. Wipe grease off needle selector plate		
		2. The N.S.P. operation lever is squeezed between the operation lever presser and the rotary cam holder body N.S.P. operation lever does not move easily.	2. Replace needle selector unit		See P. 40, P. 41
		3. Needle bent or broken	3. Replace knitting needle		
		4. Hook of needle selector plate spring is making contact with other needle selector plates	4. Correct to hook the needle selector spring		
	Knitting needle not selected at 8 cycles	1. The butt or shank of needle bent	1. Replace knitting needle		
		2. Holes in needle bed worn and enlarged	2. Replace needle bed		
	No needle selection in 24th cycle	1. The rotary cam lever remains at lower position.	1. Lubricate the card reader guide plate		
		2. The position of card reader guide plate is too much to the left.	2. Correct horizontal adjustment of card reader guide plate		See P. 53
3. Rotary cam is out of adjustment horizontally. Needle selector plate travel is too short (Rotary cam is positioned too much to the right)		3. Correct horizontal adjustment of rotary cam		See P. 53	
Unnecessary needles come out at 24th cycles	1. The rotary cam lever remains at upper position	1. Lubricate the card reader guide plate			
	2. Rotary cam is out of adjustment horizontally. Needle selector plate travel is too large (Rotary cam is positioned too much to the left.)	2. Correct horizontal adjustment of card reader guide plate		See P. 53	

4. KH-864, 868, 894 NEEDLE SELECTION MECHANISM

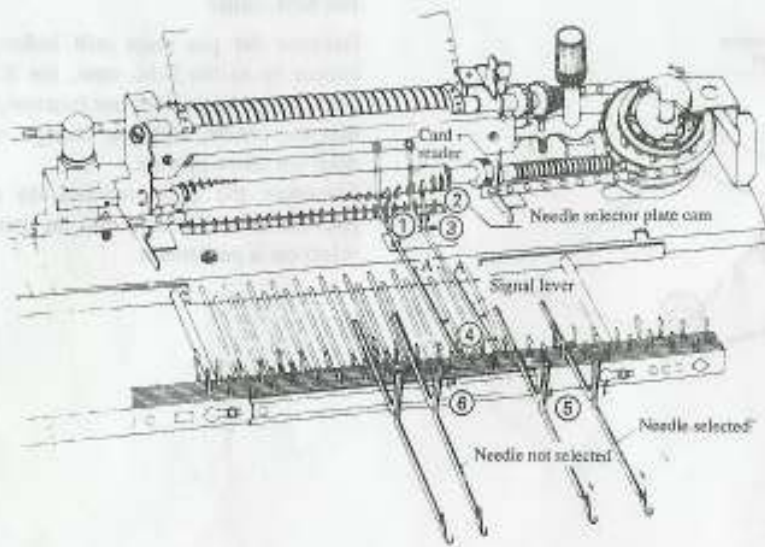

Fig. 4-1

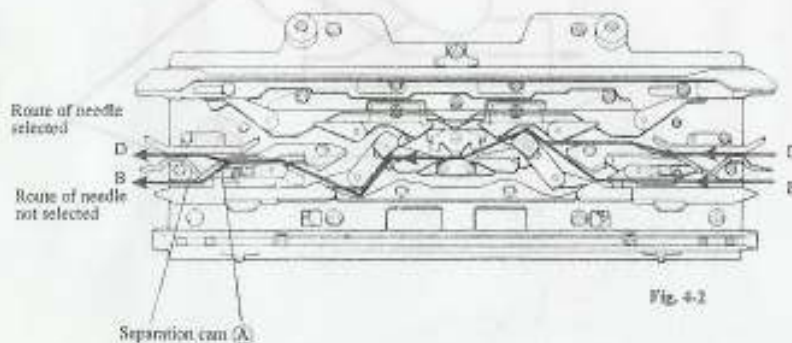

Fig. 4-2

* In the KH-864, 868, 894 needle selection mechanism, when the needle is moved downward by the needle selector cam attached to the carriage, the card reader in the position of open hole in the punched card moves up. When the card reader moves up, the card reader is forced to the left by the rotary cam, thus causing the N.S.P. operation lever (which is coupled to the card reader) to move. Thus, the N.S.P. operation lever causes the needle selector plate to the right, and the needle shank is caught by the hook of the needle selector plate. This keeps the needle forced down, and the needle is led to the D position by the separation cam.

On the needle which is not positioned in an open hole, the card reader does not move up, and as a result, the needle cannot be held down (in other words, it returns to the home position even if held down), it is pushed back to the B position by the separation cam attached to the carriage.

Main body

- 1) If there is an open hole, the card reader is moved up by the spring.
- 2) The card reader is moved to the left by the needle selector cam.
- 3) The N.S.P. operation lever is moved to the left by the card reader.
- 4) The N.S.P. lever pivots upon A (see Fig. 4-1), and the needle selector plate moves to the right.
- 5) The needle selector plate in this position is moved to the right until it catches the needle shank, thus keeping the needle forced down.
- 6) When there is no hole, the needle selector plate does not move, and as a result, the needle returns to the home position from where it is held down.

Carriage

Since the needle positioned in an open hole is under the needle selector plate, it is carried to the D position through the separation cam.

The needle which is not positioned in an open hole is immediately forced back to the home position from the position where it is held, it operates at A (see Fig. 4-2) and forced back to B.

5. SINGLE MOTIF MECHANISM

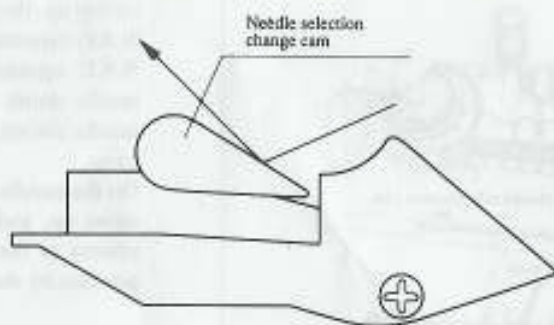
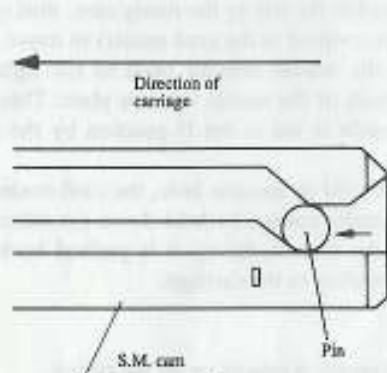

① <Before the carriage go through the S.M. cam>

Because the pin stays still before it comes up to the S.M. cam, the S.M. cam change lever does not function, so that the needle selection change cam does not move upward.

Therefore the plain needles do not pass the selection cam and no needle selection is performed.

② <While passing the S.M. cam> (Single motif needle selection)

When the pin comes over the lobe of the S.M. cam, the needle selection change cam is forced upward by the S.M. cam change lever which interlocks with the S.M. cam. As a result, the plain needles pass the selection cam to carry out the needle selection according to the design specified by the punch card.

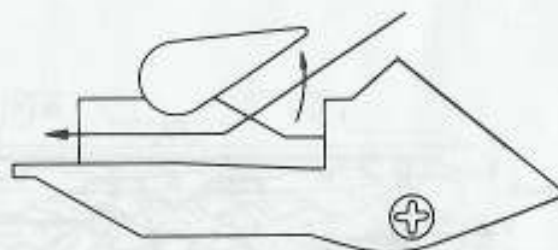
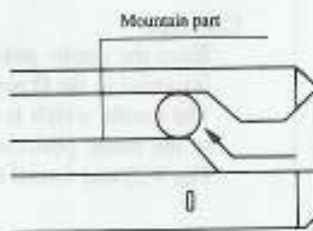

6. END NEEDLE SELECTION MECHANISM

(1) Entry side

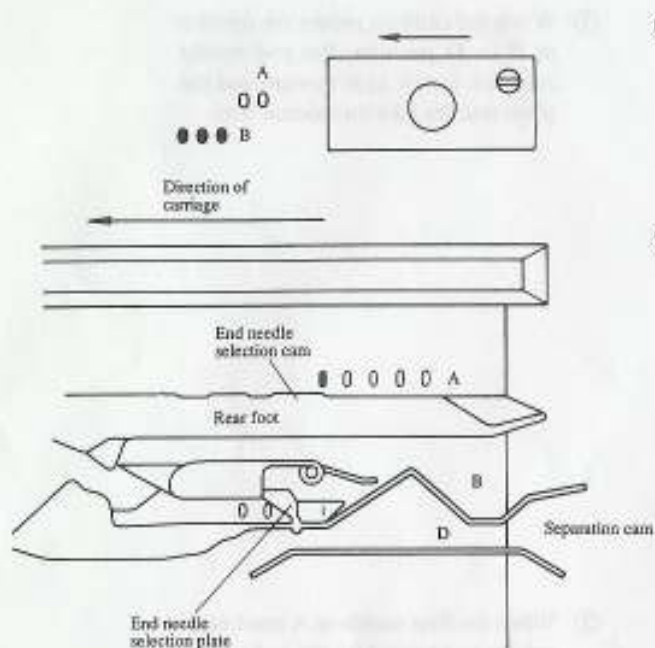

① While the carriage passes the plain needles at A position, the end needle selection cam is pressed down by the butt of each plain needle to keep the interlocked end needle selection plate pushed forward.

② Just before the last plain needle at A position comes off the end needle selection cam, the end needle at B position is let over the separation cam then fed to the route of D position by the end needle selection plate.

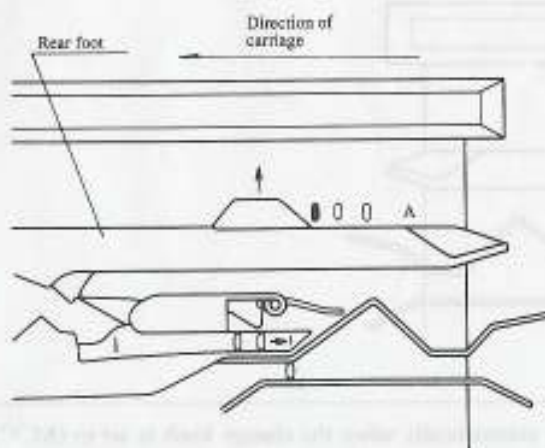

③ When the last plain needle at A position actually comes off the end needle selection cam, the end needle selection cam returns upward and the end needle selection plate also returns to its home position. Therefore the needles after the second one at B position take the normal-way to carry out the needle selection according to the design specified by the punch card.

(2) Exit side

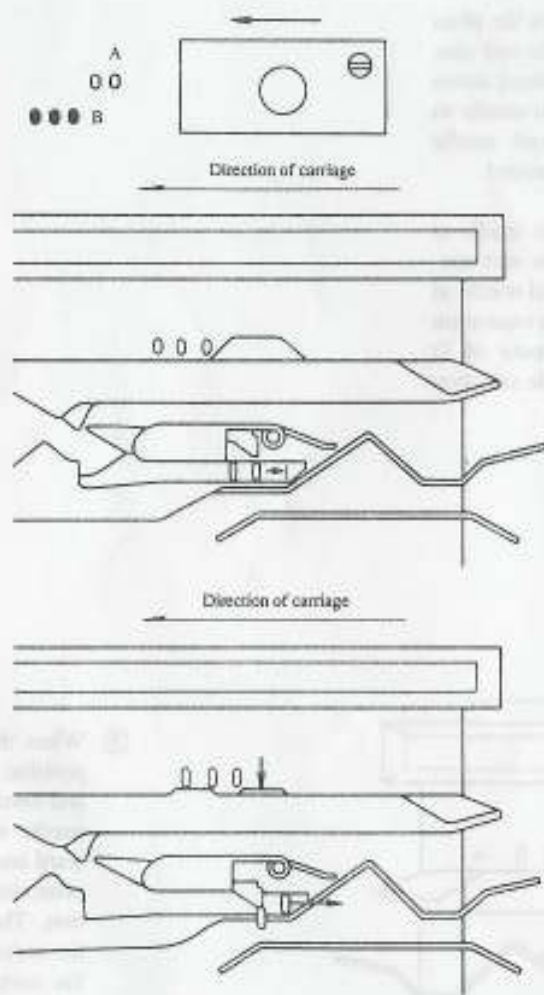

- ① While the carriage passes the needles at B or D position, the end needle selection cam is kept upward and the plain needles take the normal way.

- ② When the first needle at A position is caught and pushed by the end needle selection cam, the end needle at B position is let over the separation cam and fed to D route by the interlocked end needle selection plate.

(Note) This automatic end needle selection is carried out automatically when the change knob is set to (KC) "pattern stitch" position. Therefore, when you knit open stitch patterns, it is necessary to release the end needle selection mechanism by switching end needle selection switch cam to select no end needles at "A" position.

7. CAM BUTTON AUTO RESET MECHANISM

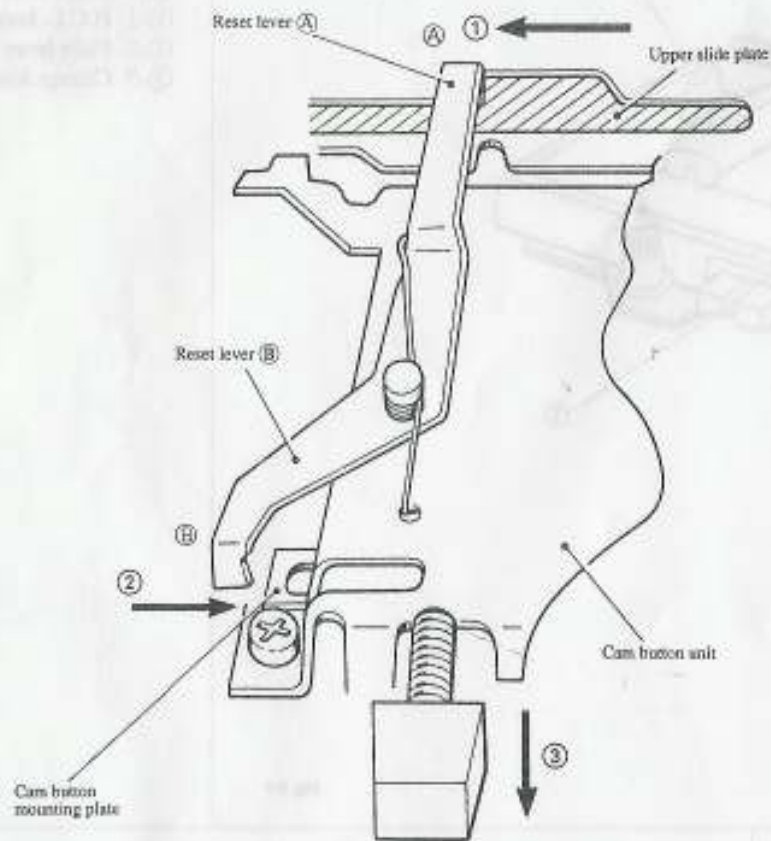

When the change knob is set to (NL) "plain stitch" position from (KC) "pattern stitch" or (SM) "single motif" position;

- ① The Reset lever (A) is moved to the left by the upper slide plate.
- ② The Reset lever (B) pivots to the right upon the shaft to push the cam button mounting plate.
- ③ The locked cam button is released and returned automatically.

8. DISASSEMBLY AND ASSEMBLY OF K CARRIAGE (KH-864, 868)

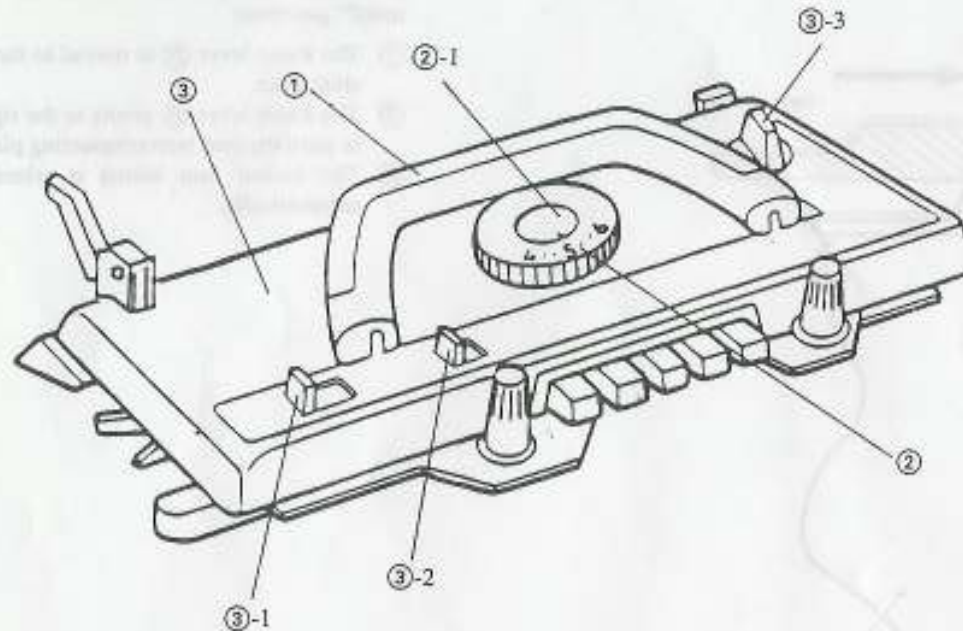

Part Nomenclature

- ① Carriage handle
- ② Stitch dial
- ②-1 Stitch dial cap
- ③ Carriage cover
- ③-1 H.C.L. knob
- ③-2 Plain lever knob
- ③-3 Change knob

Fig. 8-1

8.1 Disassembling the K carriage

1. Removing the carriage handle

- 1.1 Keep the handle down and remove the two right and left handle screws. Then the handle can be taken off the carriage.

2. Removing the stitch dial

- 2.1 Pull off the stitch dial cap upward.

- 2.2 Remove the fastening screw and pull off the stitch dial upward.

3. Removing the carriage cover

- 3.1 Loosen, from the back of the carriage, and remove the two right and left carriage cover clamp screws (tapping screws).
- 3.2 Pull off the carriage cover upward. Then the H.C.L. knob, the plain lever knob and the change knob will come off.

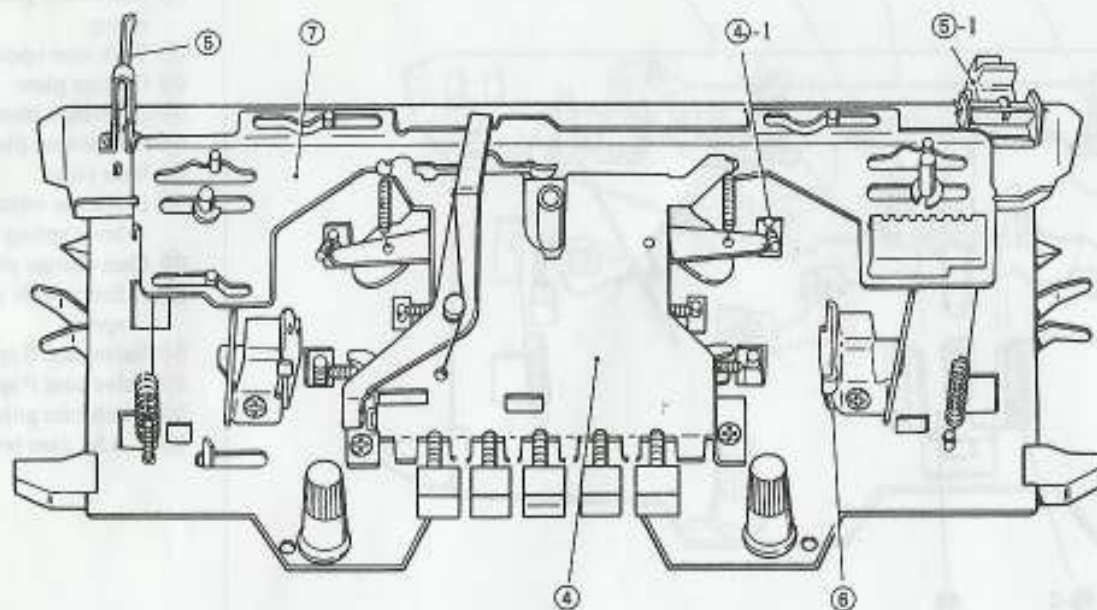

Name of parts

- ④ Cam button unit
- ④-1 Raising cam change spring
- ⑤ Knit reader tripper
- ⑤-1 Row counter tripper
- ⑥ Handle setting base
- ⑦ Upper slide plate

Fig. 8-2

4. Removing the cam button unit

- 4.1 Remove the raising cam change spring by means of a work hook used from the side of the raising cam calking pin.
- 4.2 Remove the two cam button unit clamp screws.
- 4.3 Remove the cam button unit by lifting it while pulling it toward you.

5. Removing the knit reader tripper and the row counter tripper

- 5.1 Loosen from the back of carriage and remove the knit reader tripper screws and the two row counter tripper screws, then pull off the tripper upward.

6. Removing the handle setting base

- 6.1 Remove the two right and left clamp screws and then the leaf spring.
- 6.2 Remove the two right and left clamp screws.

7. Removing the upper slide plate

- 7.1 Remove the snap rings from the change knob shaft and left side shaft using a (-) screw driver.
- 7.2 Remove the upper slide plate by lifting its right and left ends at the same time.
- 7.3 Then S.M. cam change crank will be removed.

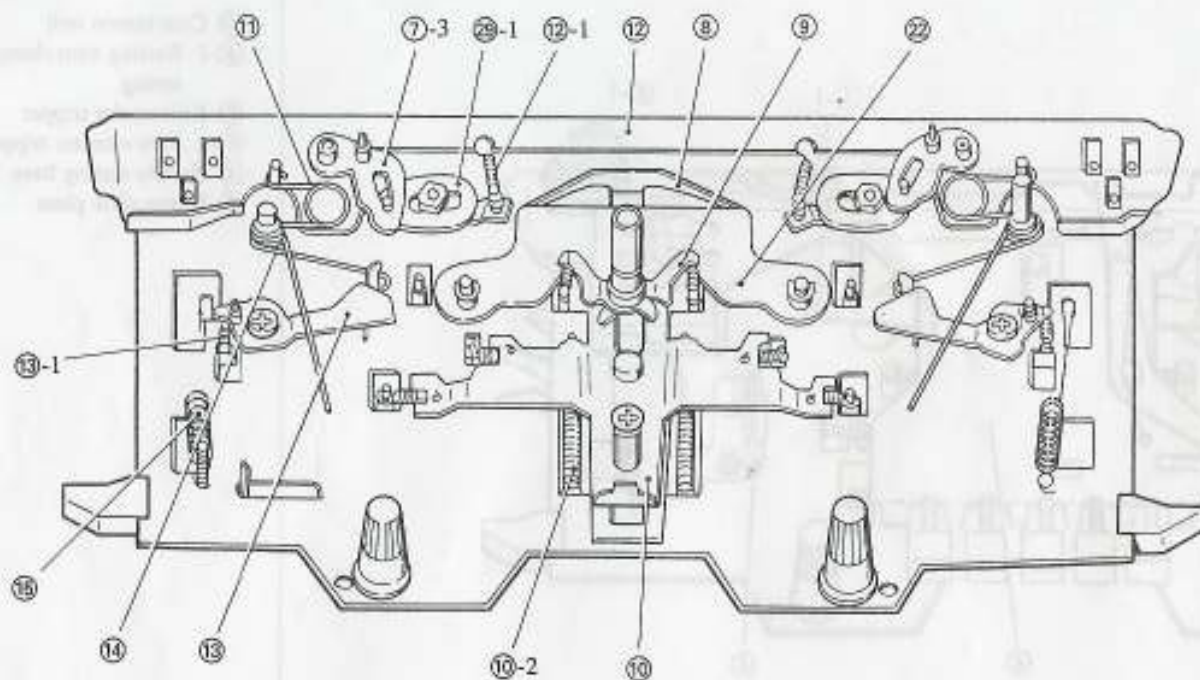

Name of parts

- ⑦-3 S.M. cam change crank
- ⑧ Stitch cam guide plate spring
- ⑨ Tuck cam operating plate
- ⑩ Change plate
- ⑩-2 Change plate spring
- ⑪ Connecting plate spring
- ⑫ Rear plate
- ⑫-1 Needle selection change lever spring
- ⑬ Cam change plate
- ⑬-1 End needle selection cam spring
- ⑭ Valve cam E spring
- ⑮ Valve cam F spring
- ⑳-1 S.M. cam lever

Fig. 8-3

8. Removing the stitch cam guide plate spring

8.1 Remove the stitch cam guide plate spring by pressing this center toward the stitch cam guide plate.

9. Removing the tuck cam operating plate in left and right

9.1 2 springs of tuck cam operating plate will be removed at the place of calking.

9.2 Lift and pull off the presser ring and the tuck cam operating plate.

10. Removing the change plate

10.1 Remove the four right and left MC cam springs from the MC cam.

10.2 Remove the right and left ends of the change plate spring from the change plate.

10.3 Remove the nuts from the change plate clamp screws using a box driver from the back of the carriage.

10.4 Remove the change plate clamp screw(s) with a driver. Lift and pull off the plate.

11. Removing the connecting plate spring

11.1 Lift and pull off the two springs on the left and right.

12. Removing the carriage rear plate

12.1 Remove the needle selection change lever spring from the rear plate and the rear plate will come off.

13. Remove the cam change plate

13.1 Remove the end needle selection cam spring R,L from the selection cam for R,L end needle.

13.2 Remove the cam change plate clamp screws.

14. Remove the valve cam E spring

15. Remove the valve cam F spring

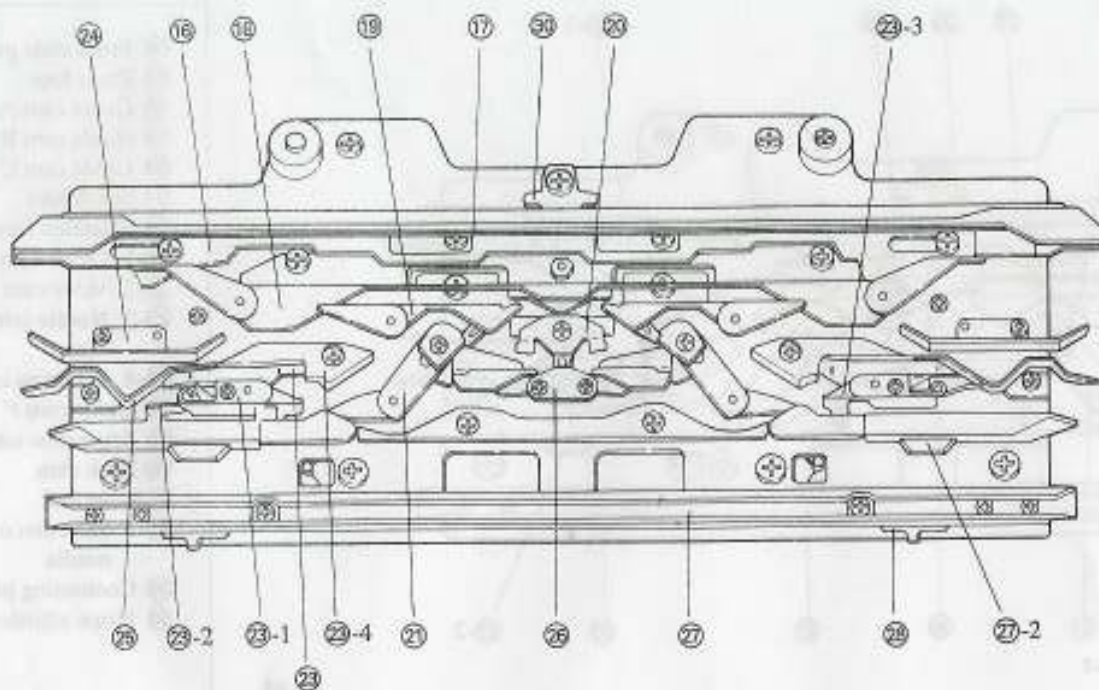

Name of parts

- ①⑥ Front slide plate
- ①⑦ Front foot
- ①⑧ Guide cam A
- ①⑨ Guide cam B
- ②① Guide cam C
- ②① Stitch cam
- ②③ Selection cam
- ②③-1 Guide cam G
- ②③-2 Valve cam F
- ②③-3 Needle selection change cam
- ②③-4 Selection cam plate
- ②④ Guide cam F
- ②⑤ Separation cam
- ②⑥ Tuck cam
- ②⑦ Rear foot
- ②⑦-2 Selection cam for end needle
- ②⑧ Connecting plate
- ②⑩ Stripe adjuster plate

Fig. 8-4

- 16. **Remove the front slide plate**
 - 16.1 Remove the H.C.L. spring.
 - 16.2 Remove washer put on the H.C.L. knob shaft on the outer side of the carriage.
 - 16.3 Remove the two front slide plate stud screws. Then lift and pull off the front slide plate. (When pulling off the plate, keep the H.C.L. knob at position H.)
- 17. **Remove the carriage from foot**
 - 17.1 Remove the two carriage front foot clamp screws and then the foot itself.
- 18. **Removing guide cam A**
 - 18.1 Remove the two right and left guide cam A clamp screws and then the cam itself. (Slide cam as well)
- 19. **Removing guide cam B**
 - 19.1 Remove the left guide cam B clamp screw and then the left section of the cam.

- 19.2 Remove the right section in the same manner.
- 20. **Removing guide cam C**
 - 20.1 Remove the guide cam C clamp screw, and guide cam C, valve cam C, the valve cam C spring, guide cam C shaft, slide cam guide and clamp screw will come off.
- 21. **Removing the stitch cam**
 - 21.1 Remove snap ring from the stitch cam shaft on the outer side of the carriage.
 - 21.2 Remove the nut from the sub stitch cam using a box driver from the outer side of the carriage.
 - 21.3 Remove the left stitch cam clamp screw, and the left part of valve cam D, the left part of the valve cam D spring, the sub-stitch cam, the sub-stitch cam shaft (collar), the left part of the MC cam and the clamp screw will come off.
 - 21.4 Remove the right part of the stitch cam in a similar way.

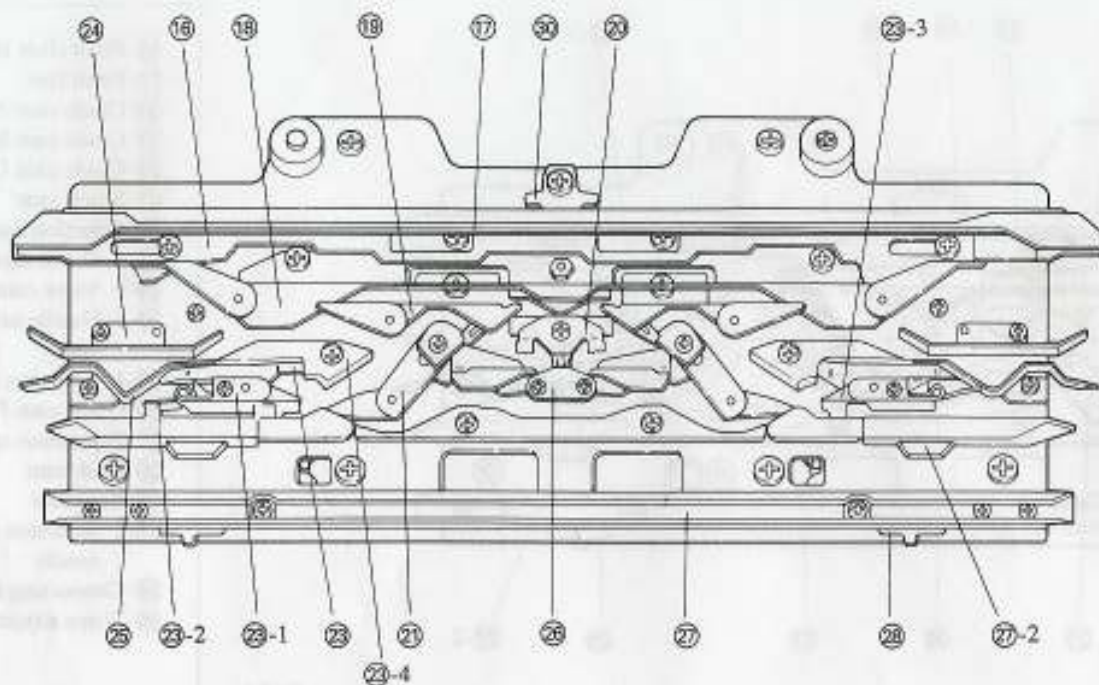

Name of parts

- 16 Front slide plate
- 17 Front foot
- 18 Guide cam A
- 19 Guide cam B
- 20 Guide cam C
- 21 Stitch cam
- 22 Selection cam
- 23-1 Guide cam G
- 23-2 Valve cam F
- 23-3 Needle selection change cam
- 23-4 Selection cam plate
- 24 Guide cam F
- 25 Separation cam
- 26 Tuck cam
- 27 Rear foot
- 27-2 Selection cam for end needle
- 28 Connecting plate
- 29 Stripe adjuster plate

Fig. 8-5

22. Removing the stitch cam guide plate

22.1 Remove the snap ring 7 and washer from the stitch cam plate shaft, and the cam plate will come off.

23. Removing the selection cam

23.1 Loosen the guide cam G clamp screws and remove the guide cam G. Then the valve cam F and the needle selection change cam will be removed.

23.2 Loosen the selection cam clamp screws and remove the selection cam and selection cam plate.

24. Removing the guide cam F

24.1 Remove the right and left guide cam F clamp screws, and the right and left parts of guide cam F will come off.

25. Removing the separation cam

25.1 Remove the right and left separation cam clamp screws and then the cam itself.

25.2 Then the buffer R,L for selected needle will be removed themselves.

26. Removing the tuck cam

Remove the right and left tuck cam clamp screws, and the tuck cam plate, the right and left parts of the tuck cam, the tuck cam spring, the tuck cam shafts and the clamp screws will come off.

27. Removing the carriage rear foot

27.1 Remove the six rear foot clamp screws and the foot will come off.

27.2 Then the selection cam for R,L end needle, the selection guide for R,L end needle with end needle selection switch cam and selection guide spring will be removed themselves.

28. Removing the connecting plate

29. Removing the needle selection change plate

29.1 Loosen the nut by box driver and remove the S.M. cam lever.

29.2 Loosen the needle selection change plate clamp screw and remove the needle selection change plate.

30. Removing the stripe adjuster plate

30.1 Remove the stripe adjuster plate clamp screw and then the plate itself.

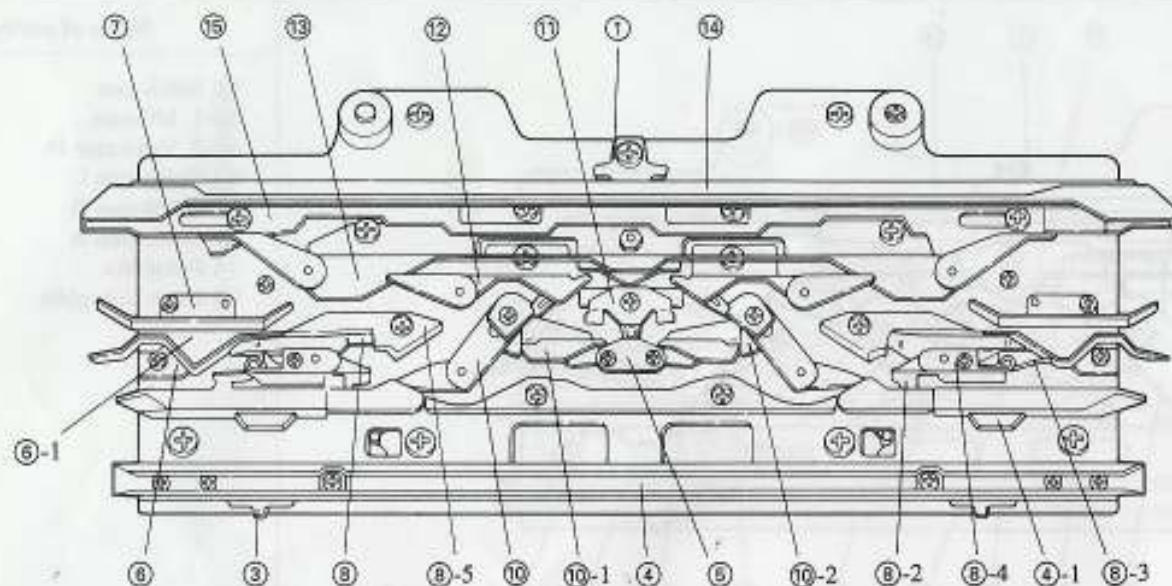

Name of parts

- ① Stripe adjuster plate
- ③ Connecting plate
- ④ Rear foot
- ④-1 Selection cam for end needle
- ⑤ Tuck cam
- ⑥ Separation cam
- ⑥-1 Buffer for selected needle
- ⑦ Guide cam F
- ⑧ Selection cam
- ⑧-2 Needle selection change cam
- ⑧-3 Valve cam F
- ⑧-4 Guide cam G
- ⑧-5 Selection cam plate

Fig. 8-6

8.2 Assembling the K carriage

1. Mounting the stripe adjuster plate

1.1 Mount the stripe adjuster plate and clamp provisionally.

2. Mounting the needle selection change plate

2.1 Put the needle selection change plate with needle selection change lever spring and fasten the needle selection change plate clamp screws. Then fit the S.M. cam lever to the needle selection change plate from outer side of the carriage and fasten the nut.

3. Mounting the connecting plate

3.1 Fit the right and left parts of the connecting plate into the carriage plate. (Take care not to mistake the right part for the left part or vice versa.)

4. Mounting the rear foot

4.1 Put the selection cam for R,L end needle on the carriage plate. (Place the convex part inside.)

4.2 Fit the selection guide for R,L end needle with end needle selection switch cam to rear foot.

And put selection guide spring into the concave part of rear foot.

4.3 Put the rear foot into position and clamp with screws.

5. Mounting the tuck cam

5.1 Fit right and left clamp screws into the tuck cam plate, mount the right and left parts of the tuck cam, the tuck cam collar and the tuck cam spring on the screws, and clamp. (Be careful of the direction of the tuck cam spring.)

Note: Keep the tuck cam open sideways. It should return easily under spring pressure.

6. Mounting the separation cam

6.1 Put the buffer R,L for selected needle into the carriage plate.

6.2 Put the left part of the separation cam on the left end of the carriage. Then clamp the separation cam clamp screw into the outer screw hole.

6.3 Fit the right part of the separation cam in a similar way.

7. Mounting guide cam F

7.1 Mount the left part of guide cam F and clamp.

7.2 Mount the right part of guide cam F in a similar way.

8. Mounting the selection cam

8.1 Fit the selection cam and clamp with screw.

8.2 Put the needle selection change cam into the hole of shaft on the carriage plate. And put the pin of needle selection change cam into the hole of needle selection change plate.

8.3 Put the valve cam F into the shaft of the carriage plate.

8.4 Fit the guide cam G to selection cam and clamp with screw.

9. Mounting the stitch cam guide plate

9.1 Mount the stitch cam guide plate from the outer side of the carriage. Put washers on the right and left parts of the stitch cam shaft bearing from the back side of the carriage and stop with snap ring 7.

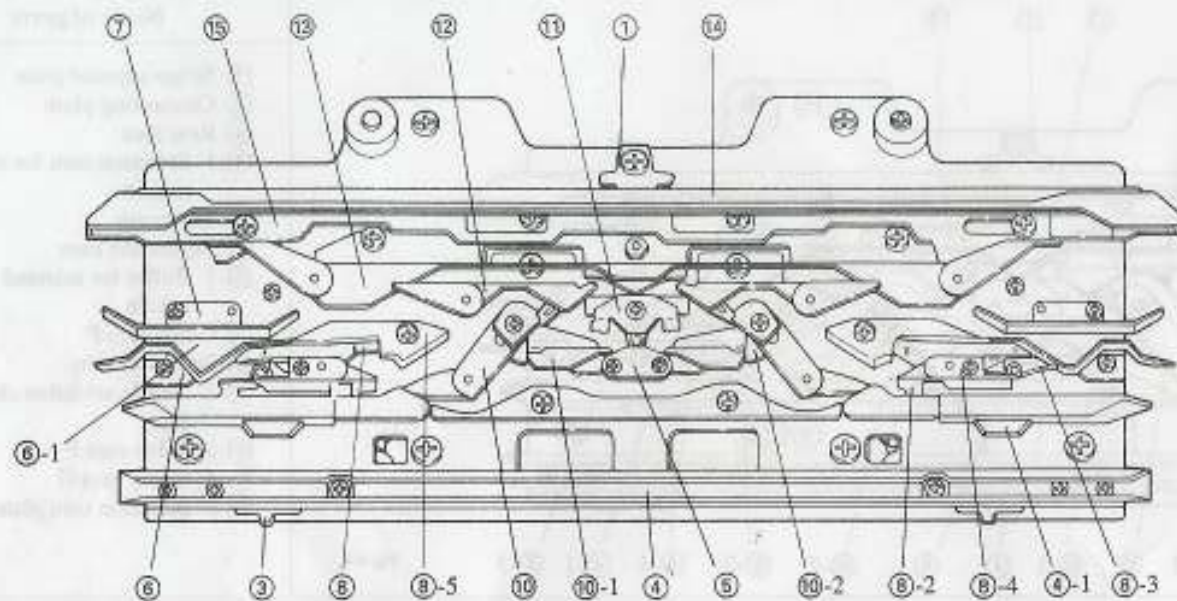

Name of parts

- ⑩ Stitch cam
- ⑩-1 MC cam
- ⑩-2 Valve cam D
- ⑪ Guide cam C
- ⑫ Guide cam B
- ⑬ Guide cam A
- ⑭ Front foot
- ⑮ Front slide plate

Fig. 8-7

10. Mounting the stitch cam

10.1 Fit the left part of the MC cam, the sub stitch cam shaft (collar), the left part of the valve cam D spring, the left part of valve cam D, the stitch cam and the left part of the sub stitch cam into the carriage plate in this order and clamp with a screw. Fix with a nut from the outer side of the carriage. (The ring part of the valve cam D spring should be hung from valve cam D and the hook part from the left part of the sub stitch cam.)

10.2 Mount the right part of the stitch cam in a similar way.

10.3 Clamp the stitch cam shaft with a washer and snap ring 3 on the outer side of the carriage.

Note: 1. The MC cam, valve cam D and the stitch cam should work easily.

2. Valve cam D should return under spring pressure.

11. Mounting guide cam C

11.1 Build the slide cam guide, shaft for guide cam C, Valve cam C spring and valve cam C in this order. And clamp with screw. (The ring part of the valve cam C should be hung from valve cam C and the hook part from the right-hand notch of guide cam C.)

Note: The valve cam C should work easily. Valve cam C should return to the center under spring pressure.

12. Mounting guide cam B

12.1 Fit the valve cam B spring onto the valve cam B shaft and put guide cam B in position B and clamp with a screw while keeping valve cam B at the ring part of the valve cam B spring.

Note: Turn valve cam B inside the sub stitch cam.

13. Mounting guide cam A

13.1 Mount guide cam A and slide cam clamp with right and left screws.

14. Mounting the carriage front foot

14.1 Tighten the two screws provided near the center of the carriage front foot.

15. Mounting the front slide plate

15.1 Put the front slide plate on the carriage front foot and clamp with set-screws. (The longer screw is used for left side.)

Note: See to it that the slide plate will work easily and that the holding cam will go down when the slide plate is moved to the H (Holding) position.

15.2 Fix the holding cam lever shaft with a washer and H.C.L. spring from the outer side of the carriage.

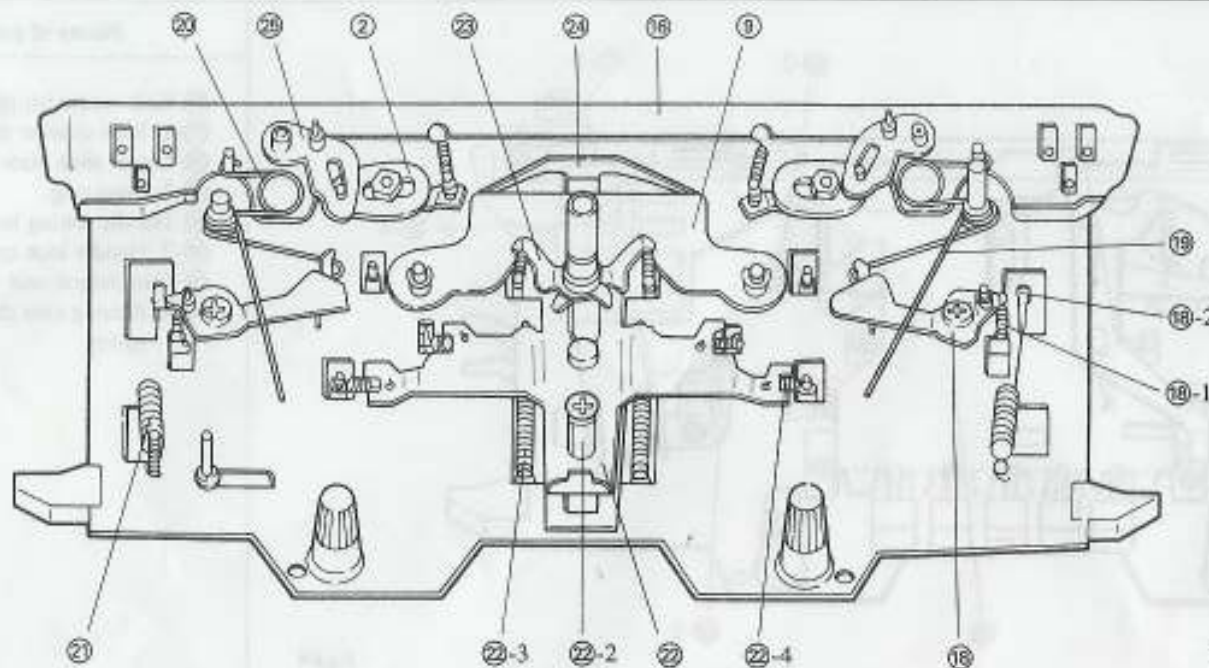

Fig. 8-8

Name of parts

- ② S.M. cam lever
- ⑨ Stitch cam guide plate
- ⑬ Rear plate
- ⑭ Cam change plate
- ⑭-1 End needle selection cam spring
- ⑭-2 Selection cam for end needle
- ⑮ Valve cam E spring
- ⑯ Connecting plate spring
- ⑰ Valve cam F spring
- ⑱ Change plate
- ⑱-2 Change plate guide collar
- ⑱-3 Change plate spring
- ⑱-4 MC cam spring
- ⑲ Tuck cam operating plate
- ⑳ Stitch cam guide plate spring
- ㉑ S.M. cam change crank

16. Mounting the rear plate

- 16.1 Put the rear plate on the carriage plate.
- 16.2 Hook the needle selection change lever spring to the calking of rear plate.

17. Mounting the knit reader tripper and the row counter tripper

- 17.1 Put the row counter tripper and knit reader tripper on the left and right side of the carriage plate.
- 17.2 From inner side of the carriage fasten four screws.

18. Mounting the cam change plate

- 18.1 Put the cam change plate with end needle selection cam spring on the carriage and fasten the screws.
- 18.2 Hook the end needle selection cam spring to the hook of selection cam for R,L end needle in outer side of the carriage.

19. Mounting the valve cam E spring

- 19.1 Fit the valve cam E spring to the shaft of carriage.
- 19.2 Hook the U part to the valve cam E (which is combined with rear foot).

20. Mounting the connecting plate spring

- 20.1 Hook the connecting plate spring, right to the shaft for change knob.
- 20.2 Hook the connecting plate spring, left to the shaft for valve cam E spring. (Take care not to mistake right or left.)

21. Mounting the valve cam F spring

- 21.1 Hook the valve cam F spring to the valve cam F and the pin of front slide plate clamp screws.

22. Mounting the change plate

- 22.1 Mount the change plate with the change plate guide collar.
- 22.2 Tighten the change plate guide collar with a nut from the back side of the carriage.
- 22.3 Hook the change plate spring to the hook of the change plate and front foot.
- 22.4 Hook four points of the MC cam spring to the right and left parts of the MC cam and the right and left parts of the hook of the guide cam B.

Note: The change plate, the right and left parts of the MC cam and the right and left parts of MC knitting change cam (the guide cam B) should return under spring pressure after being pressed. The change plate should operate easily.

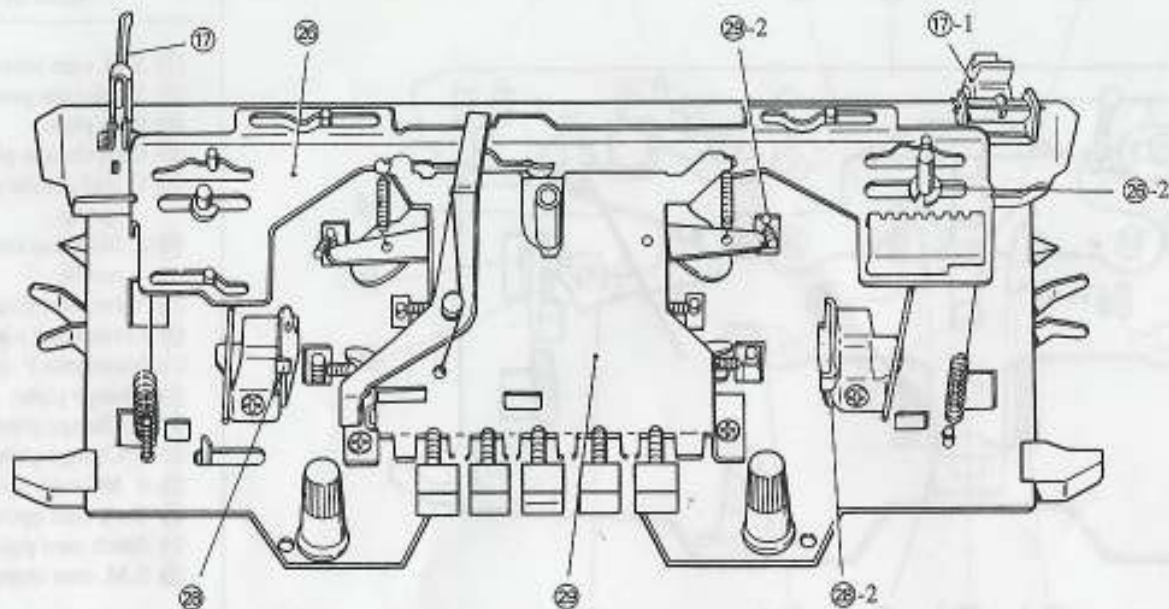

Fig. 8-9

Name of parts

- ⑰ Knit reader tripper
- ⑰-1 Row counter tripper
- ⑳ Upper slide plate
- ㉘-2 Snap ring
- ㉘ Handle setting base
- ㉘-2 Handle lock spring
- ㉘ Cam button unit
- ㉘-2 Raising cam change spring

23. Mounting the tuck cam operating plate

23.1 Put the right part of the tuck cam operating plate on the tension dial shaft and place on it the left part of the tuck cam operating plate and the collar.

23.2 Hook the right and left ends of the tuck cam operating plate spring to the tuck cam calking pin.

24. Mounting the stitch cam guide plate spring

24.1 Mount the stitch cam guide plate spring.

25. Mounting the S.M. cam change crank

25.1 Put the S.M. cam change crank into the Pin of rear foot clamp screw.

25.2 Fix the hole of S.M. cam change crank to the short pin of S.M. cam lever.

26. Mounting the upper slide plate

26.1 Insert the grooves of the upper slide plate into 4 pins of S.M. cam change crank, two shafts hooked connecting plate spring and cam change plate.

26.2 Fix the plate with snap ring at the shaft hooked connecting plate spring and valve cam E spring.

27. Mounting the change knob

27.1 Insert the change knob into the right shaft for change knob.

Note: 1. In condition that the upper slide plate is left end, the red mark of change knob should indicates downwards.

2. The upper slide plate should move easily.

28. Mounting the handle base

28.1 Clamp the right and left parts of the handle base with two clamp screws.

28.2 Clamp the right and left parts of the handle lock spring with screws.

29. Mounting the cam button unit

29.1 Mount the cam button unit on the tension dial shaft and clamp with screws at right and left.

29.2 Hook the raising cam change spring cam calking pin.

Note: 1. The cam should be switch accurately when the right or left of the TUCK, the right or left of the PART or MC button is pressed.

2. When the change knob is moved to N.L. position (the red mark indicates downwards), the TUCK, the PART and MC button pressed before should return.

9. DISASSEMBLY AND ASSEMBLY OF K CARRIAGE (KH-894)

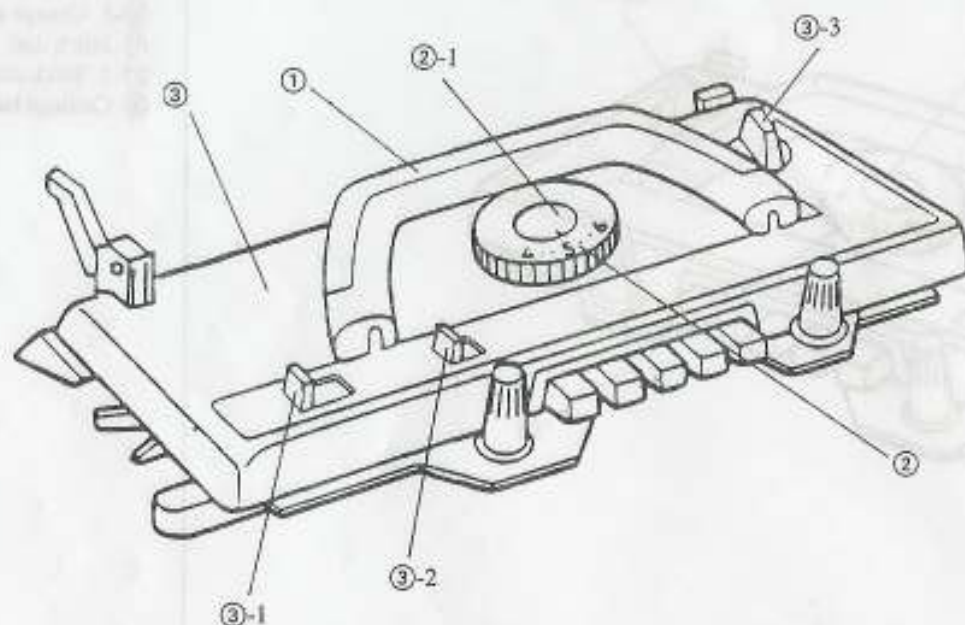

Part Nomenclature

- ① Carriage handle
- ② Stitch dial
- ②-1 Stitch dial
- ③ Carriage cover
- ③-1 H.C.L. knob
- ③-2 Plain lever knob
- ③-3 Change knob

Fig. 9-1

9.1 Disassembling the K carriage

1. Removing the carriage handle

- 1.1 Keep the handle down and remove the two right and left handle screws. Then the handle can be taken off the carriage.

2. Removing the stitch dial

- 2.1 Pull off the stitch dial cap upward.
- 2.2 Remove the fastening screw and pull off the stitch dial upward.

3. Remove the carriage cover

- 3.1 Loosen, from the back of the carriage, and remove the two right and left carriage cover clamp screws (tapping screws).
- 3.2 Pull off the carriage cover upward. Then the H.C.L. knob, the plain lever knob and the change knob will come off.

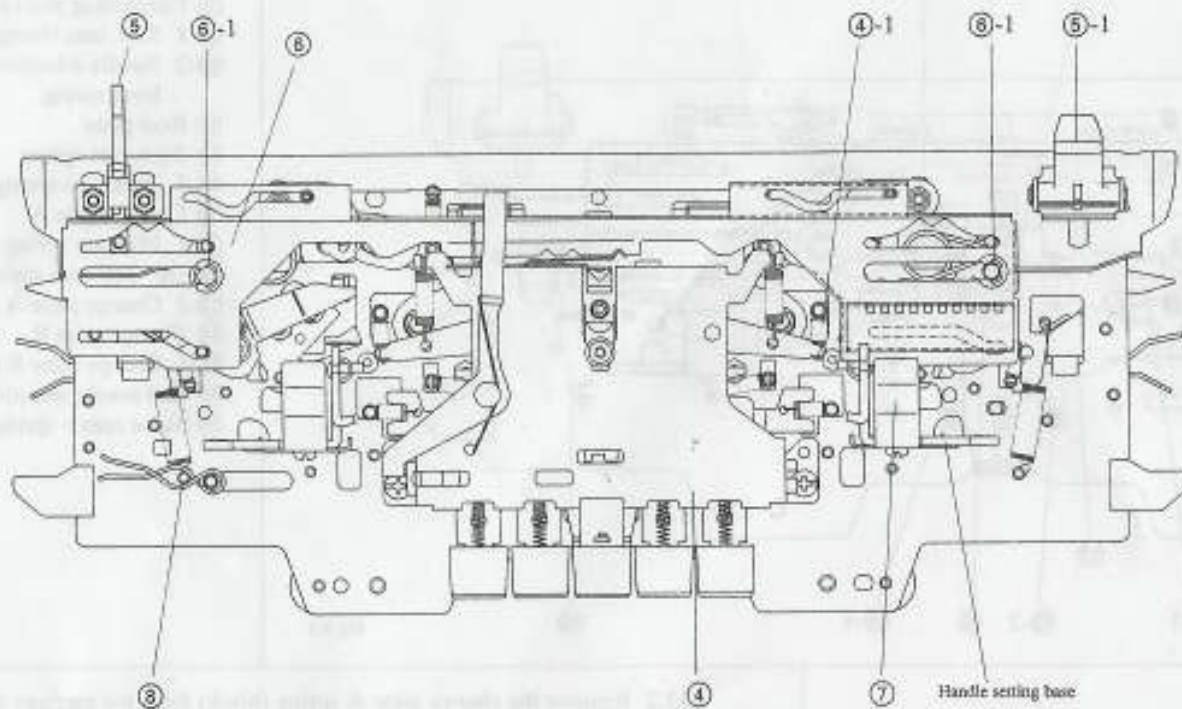

Part nomenclature

- ④ Cam button unit
- ④-1 Raising cam switch spring
- ⑤ Knit reader tripper
- ⑤-1 Row counter tripper
- ⑥ Upper slide plate
- ⑥-1 Snap ring
- ⑦ Handle lock spring
- ⑧ Front slide plate spring

Fig. 9-2

4. Removing the cam button unit

- 4.1 Remove the raising cam switch spring from the cam button unit side.
- 4.2 Remove the two screws from the cam button unit, raise the cam button unit and separate the hammer in the screw section from the carriage plate, and pull it out toward you.

5. Removing the knit reader tripper and the row counter tripper

- 5.1 Remove the two screws from the knit reader tripper and the row counter tripper from the rear of the carriage.

6. Removing the upper slide plate

- 6.1 Remove the snap ring from the change knob shaft and the left side shaft.
- 6.2 Remove upper slide plate by lifting the left and right ends up at the same time.

7. Removing the handle lock spring

- 7.1 Remove the left and right handle lock spring screws from the handle setting base crimped onto the carriage plate.

8. Removing the H.C.L. spring

- 8.1 Remove the H.C.L. spring.

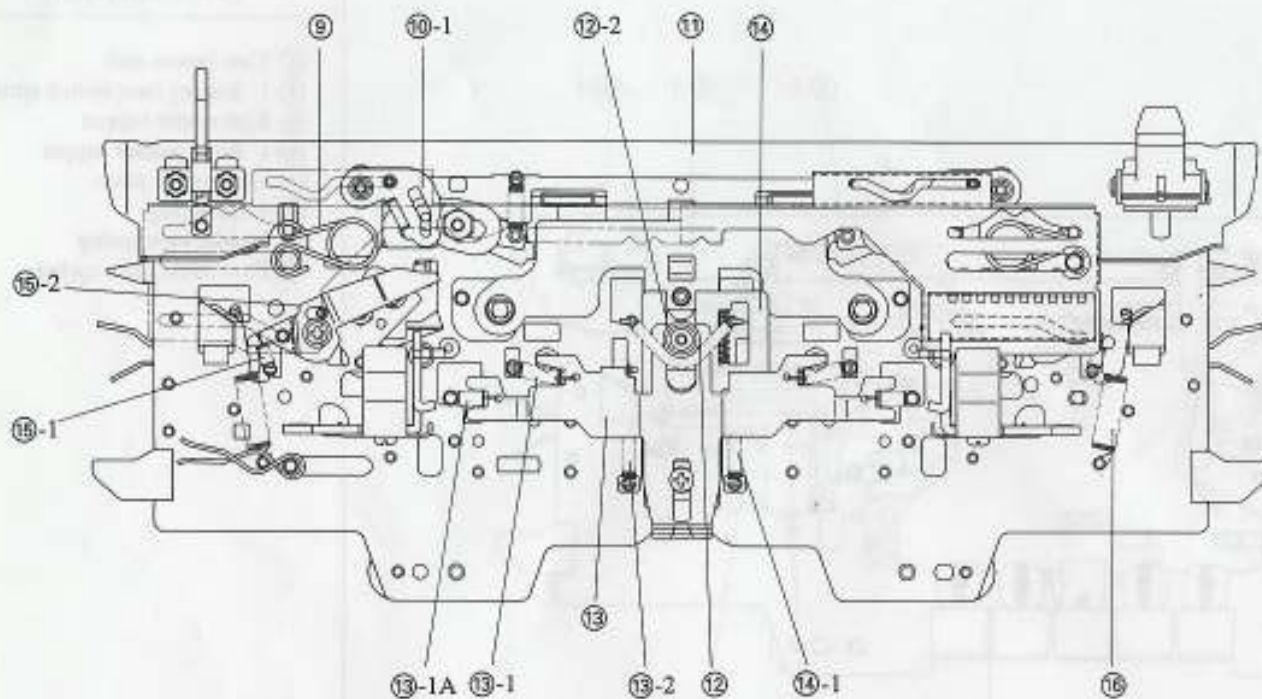

Fig. 9-3

Part nomenclature

- ⑨ Connecting plate spring
- ⑩-1 S.M. cam change crank
- ⑩-2 Needle selection change lever spring.
- ⑪ Rear plate
- ⑫ Tuck cam spring
- ⑫-2 Tuck cam spring collar
- ⑬ Change plate A
- ⑬-1 MC cam spring
- ⑬-1A MC cam spring
- ⑬-2 Change plate A spring
- ⑭ Change plate B
- ⑭-1 Change plate B spring
- ⑮ End needle selection spring
- ⑯ Valve cam F spring

9. Removing the connecting plate spring

9.1 Lift and pull off left and right connecting plate springs.

10. Removing the S.M. cam change crank

10.1 Pull up and remove the right and left S.M. cam change cranks.

10.2 Remove the right and left needle selection change lever springs from the carriage rear plate.

11. Removing the carriage rear plate

11.1 Raise the carriage rear plate as it is and remove it.

12. Removing the tuck cam spring and presser ring collar

12.1 Remove the hooks on the two ends of the tuck cam spring from the tuck cam spring hook catches.

12.2 Remove the tuck cam spring collar from the stitch dial shaft.

13. Removing change plate A

13.1 Remove the four left and right MC cam springs and the four left and right MC cam springs A from the cam side.

13.2 Remove the change plate A spring (black) from the carriage front foot side.

13.3 Remove the change plate guide collar and lift change plate A up and out.

14. Removing change plate B

14.1 Remove change plate B spring from the carriage front foot side.

14.2 Remove change plate B spring and lift change plate B up and out (as well as the stitch cam collar).

15. Removing the cam change plate

15.1 Remove the valve cam E springs from the carriage calking pin and the valve cam E.

15.2 Remove the right and left cam change plates by removing the two screws.

16. Removing valve cam F spring

16.1 Remove valve cam F spring from valve cam F and the front slide plate set screw.

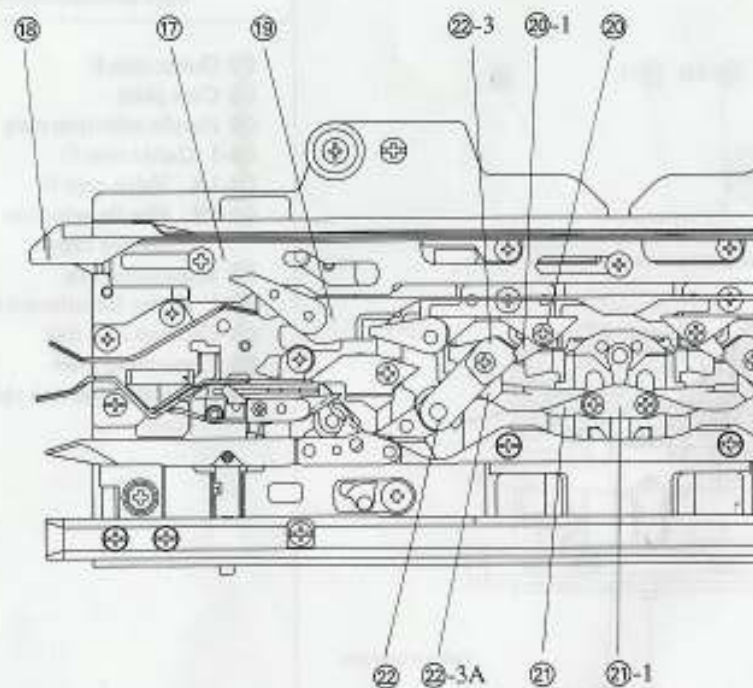

Carriage front side

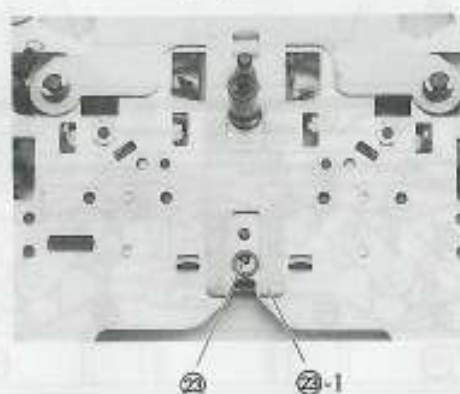

Fig. 9-4

Part nomenclature

- ⑰ Front slide plate
- ⑱ Carriage front foot
- ⑲ Guide cam A
- ⑳ Guide cam B
- ㉔-1 Valve cam B
- ㉕ Tuck cam
- ㉕-1 Tuck cam plate
- ㉖ Stitch cam
- ㉖-3 Sub stitch cam
- ㉖-3A Valve cam D
- ㉗ Stitch cam collar
- ㉗-1 Stitch cam guide plate

*Carriage rear

17. Removing the front slide plate

17.1 Remove the two set screws on the left and right and the one in the center of the front slide plate, and lift the front slide plate up and off.

18. Removing the carriage front foot

18.1 Remove the two carriage front foot clamp screws and then the foot itself.

19. Removing guide cam A

19.1 Remove the two left and right guide cam A clamp screws and then the cam itself (slide cam as well).

20. Removing guide cam B and valve cam B

20.1 Remove the left guide cam B screw as well as the left valve cam B screw and remove the left guide cam B (as well as the left valve cam B, the left valve cam B spring, and valve cam B shaft). Remove the right guide cam B in a similar way (as well as the slide cam guide).

21. Removing the tuck cam

21.1 Remove the tuck cam plate screws and remove the tuck cam plate and the tuck cam (as well as the washer and the tuck cam shaft).

22. Removing the stitch cam

22.1 Remove the snap ring on the left and right stitch cam shaft from the front side of the carriage.

22.2 Remove the nut from the sub stitch cam from the front side of the carriage.

22.3 Remove the left stitch cam clamp screw, and the left sub stitch cam, the left stitch cam, the left valve cam D, the left valve cam D spring, the sub stitch cam shaft, and the left MC cam will all come off.

22.4 Remove the right stitch cam in a similar way.

23. Removing the stitch cam guide plate

23.1 When the snap ring E7 on the left and right of the stitch cam shaft and the left and right raising cam guides are removed, the stitch cam collar and the stitch cam guide plate will come off.

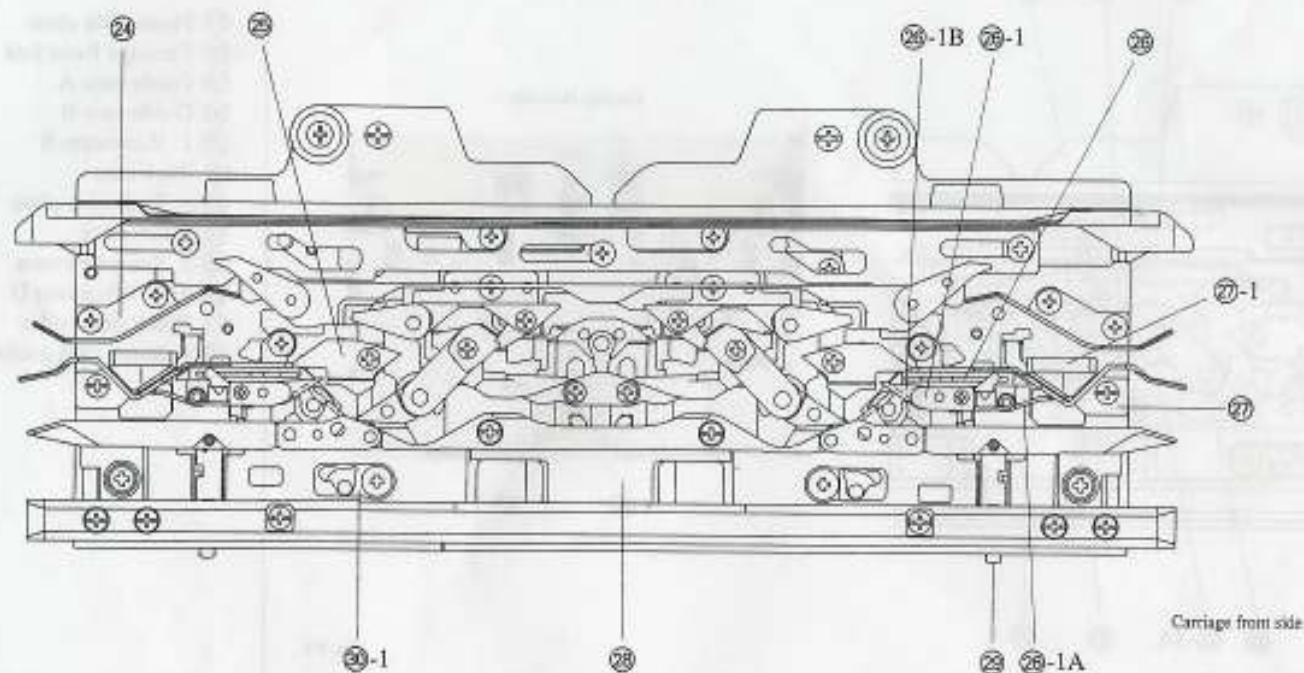

Part nomenclature

- 24 Guide cam F
- 25 Cam plate
- 26 Needle selection cam
- 26-1 Guide cam G
- 26-1A Valve cam F
- 26-1B Needle selection change cam
- 27 Separation cam
- 27-1 Buffer for selected needle
- 28 Carriage rear foot
- 29 Connecting plate
- 30-1 Needle selection change plate

Fig. 9-5

24. Removing guide cam F

24.1 Remove the left and right guide cam F clamp screws, and the left and right guide cam F will come off.

25. Removing the guide cam D

25.1 Remove the guide cam D screws and take the guide cam D off.

26. Removing the needle selection cam

26.1 Remove the guide cam G screws, and guide cam G, valve cam F, the needle selection change cam, and the needle selection cam will come off.

27. Removing the separation cam

27.1 Remove the separation cam screws, and the separation cam and the buffer for selected needle will come off.

28. Removing the carriage rear foot

28.1 Remove the six carriage rear foot screws, and the carriage rear foot will come off.

28.2 Remove the end needle selection cam, the end needle selection guide, end needle selection switch cam, end needle selection cam spring guide cam C, and the guide cam C spring.

29. Removing the connecting plate

29.1 Pull off the connecting plate by lifting it by its right and left parts near the front foot.

30. Removing the needle selection change plate

30.1 Remove the clamp screws of needle selection change plates.

30.2 Remove the shafts for needle selection change cam.

(See Parts Catalogue, part No. 157 on page 9.)

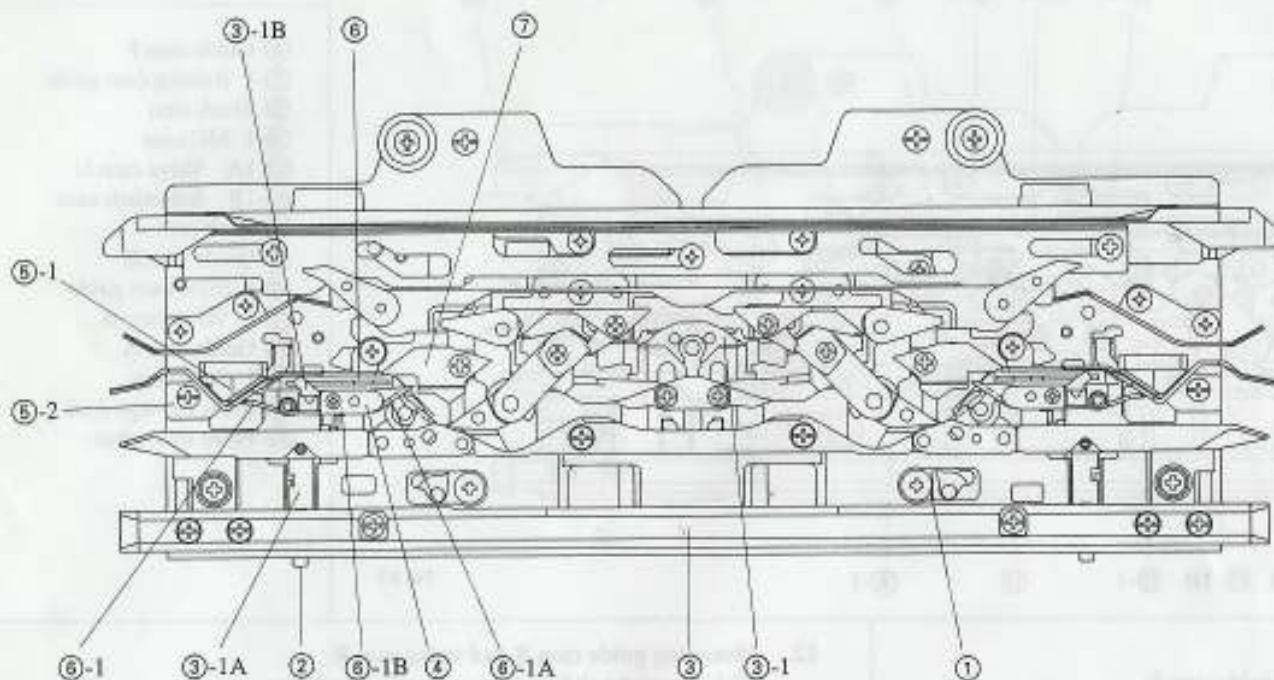

Fig. 9-6

Part nomenclature

- ② Connecting plate
- ③ Carriage rear foot
- ③-1 Guide cam C
- ③-1A End needle selection cam
- ③-1B End needle selection guide
- ④ Needle selection cam shaft
- ⑤-1 Buffer for selected needle
- ⑥-2 Separation cam
- ⑥ Needle selection cam
- ⑥-1 Valve cam F
- ⑥-1A Needle selection change cam
- ⑥-1B Guide cam G
- ⑦ Guide cam D

9.2 Assembling the K carriage

1. Mounting the needle selection change plate

- 1.1 Mount the needle selection change plates and clamp them with screws.

2. Mounting the connecting plate

- 2.1 Fit the left and right connecting plate into the carriage plate.

3. Mounting the carriage rear foot

- 3.1 Place the guide cam C spring on guide cam C and place guide cam C in the center of the carriage. After mounting the left and right end needle selection cam, the left and right needle selection guide, the end needle selection switch cam, end needle selection cam spring, mount the carriage rear foot and tighten the screws.

4. Mounting the needle selection cam shaft

- 4.1 Place the needle selection cam shaft in from the rear side of the carriage and secure the needle selection cam shaft and tighten the nuts in from the front side of carriage.

5. Mounting the separation cam

- 5.1 Fit both buffers for selected needle into the square holes of the carriage plate.
- 5.2 Mount the left and right separation cam with the screws.

6. Mounting the needle selection cam

- 6.1 Mount the valve cam F and the needle selection change cam and check the positioning of the needle selection cam. When this has been mounted, tighten the screws onto both this and guide cam G.

7. Mounting the guide cam D

- 7.1 Check the guide cam D and assemble it to the shaft, then tighten screws.

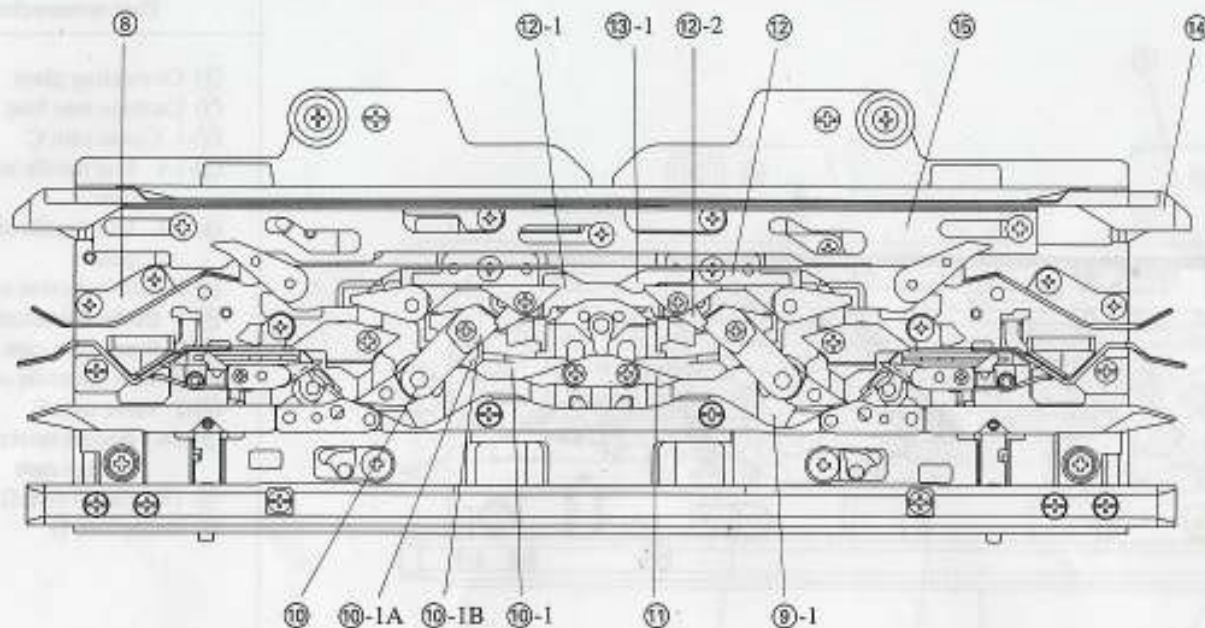

Fig. 9-7

Part nomenclature

- ⑧ Guide cam F
- ⑨-1 Raising cam guide
- ⑩ Stitch cam
- ⑩-1 MC cam
- ⑩-1A Valve cam D
- ⑩-1B Sub stitch cam
- ⑪ Tuck cam
- ⑫ Guide cam B
- ⑫-1 Slide cam guide
- ⑫-2 Valve cam B
- ⑬ Guide cam A
- ⑬-1 Slide cam
- ⑭ Front carriage foot
- ⑮ Front slide plate

8. Mounting the guide cam F

8.1 Mount and tighten the two screws of guide cam F.

9. Mounting the stitch cam guide plate

9.1 Mount the stitch cam guide plate from the front side of the carriage. Pass the stitch cam guide plate shaft through the right and left raising cam guide from the rear side of the carriage. Fasten it down with snap ring E7. *Ensure that the tip of the raising cam guide enters the carriage plate and is secured.

10. Mounting the stitch cam

10.1 Fit the MC cam, the sub stitch cam shaft, the valve cam D spring, valve cam D, the stitch cam, and the sub stitch cam, in that order, to the carriage plate and tighten it all down with a screw. Ensure that valve cam D functions with its spring.

10.2 Mount the two snap rings E3 from the front side of the carriage.

10.3 Mount the two nuts from the front side of the carriage.

11. Mounting the tuck cam

11.1 Fit the tuck cam shaft, the left and right tuck cam, the tuck cam washer, and the tuck cam plate, in that order, to the top of guide cam C and tighten it all down with a screw.

12. Mounting guide cam B and valve cam B

12.1 Insert the slide guide into the carriage plate.

12.2 Fit the valve cam B spring, the valve cam B shaft, valve cam B, and guide cam B, in that order, onto the top of the slide cam guide and tighten the valve cam B screw.

12.3 Tighten the screws on the right and left guide cam B. Valve cam B is on the inside of the sub stitch cam and should function with the spring.

13. Mounting guide cam A

13.1 Fit the slide cam to the slide cam guide.

13.2 Tighten the two screws on the right and left of guide cam A (such that the cam slides easily).

14. Mounting the front carriage foot

14.1 Tighten the front carriage foot on with the two screws.

15. Mounting the front slide plate

15.1 Put the front slide plate on top of the front carriage foot and tighten it on with 2 screws on the right and left and one screw in the middle.

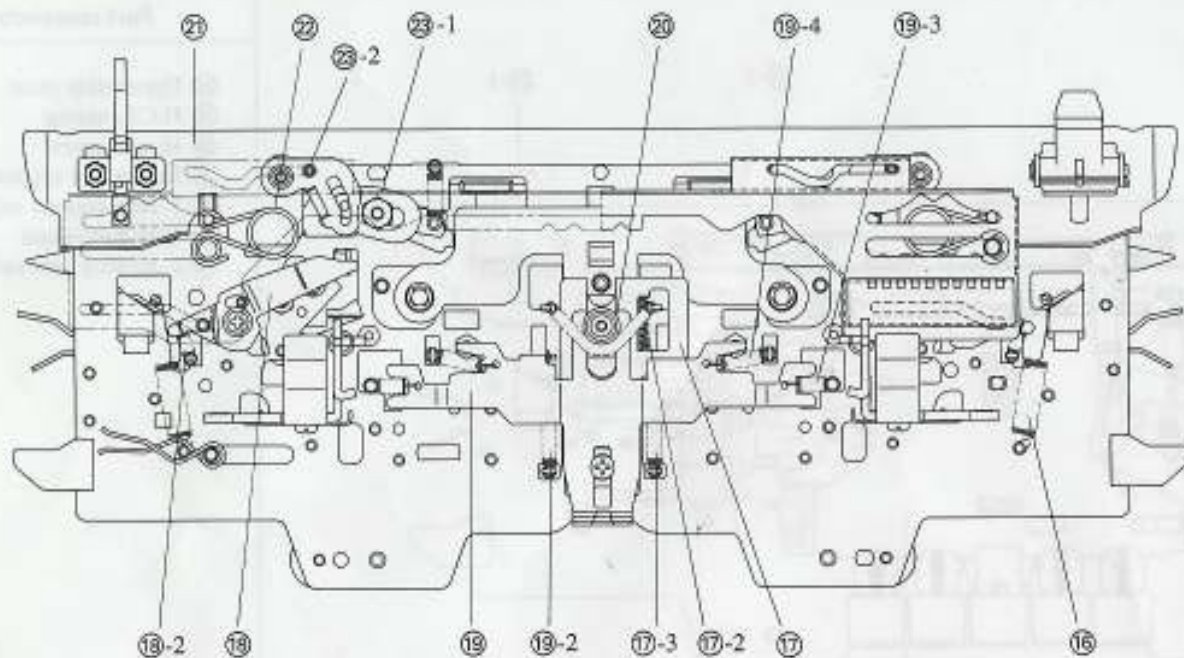

Part nomenclature

- ⑩ Valve cam F spring
- ⑪ Change plate B
- ⑪-2 Change plate spring
- ⑪-3 Change plate B spring
- ⑫ Cam change plate
- ⑫-2 Selection guide spring
- ⑬ Change plate A
- ⑬-2 Change plate A spring
- ⑬-3 MC cam spring
- ⑬-4 MC cam spring A
- ⑭ Tuck cam collar
- ⑭-1 Tuck cam spring
- ⑮ Carriage rear plate
- ⑯ Connecting plate spring
- ⑰-1 S.M. cam lever
- ⑰-2 S.M. cam change crank

Fig. 9-8

16. Mounting the valve cam F spring

16.1 Hook the valve cam F spring to the screw protruding from the carriage front foot and valve cam F.

17. Mounting change plate B

- 17.1 Put the stitch cam plate collar on the stitch cam plate groove.
- 17.2 While inserting the change plate spring, mount the dial shaft to change plate B.
- 17.3 Hook the change plate B spring to the carriage front foot.

18. Mounting the cam change plate

- 18.1 Mount and fix the cam change plate with screws.
- 18.2 Hook the selection guide springs over the selection guide for end needle and the pin of the cam change plate.

19. Mounting change plate A

- 19.1 Fit change plate A to the dial shaft and tighten the change plate guide collar in such a way that it passes through the stitch cam plate collar.
- 19.2 Hook the change plate A spring to the carriage front foot.
- 19.3 Hook the left and right MC cam spring and the left.
- 19.4 Right MC cam spring A onto their respective pins.

20. Mounting the tuck cam spring

- 20.1 Mount the tuck cam spring collar from the top of the dial shaft.
- 20.2 Hook the tuck cam spring onto the tuck cam. Hook it on in such a way that at the side with the change plate B spring, the opening part of hook of the tuck cam spring should be downside.

21. Mounting the carriage rear plate

- 21.1 Set the carriage rear plate.

22. Mounting the connecting plate spring

- 22.1 Hook the connecting plate spring to the connecting plate calking pin and the change knob shaft.

23. Mounting the S.M. cam lever and the S.M. cam change crank.

- 23.1 Put the pin of each S.M. cam lever into the hole of needle selection change plates attached on the bottom of carriage plate. And clamp them with nuts (8 mm).
- 23.2 Put the S.M. cam change cranks to the calking shafts on the carriage plate and to the pins of S.M. cam lever.

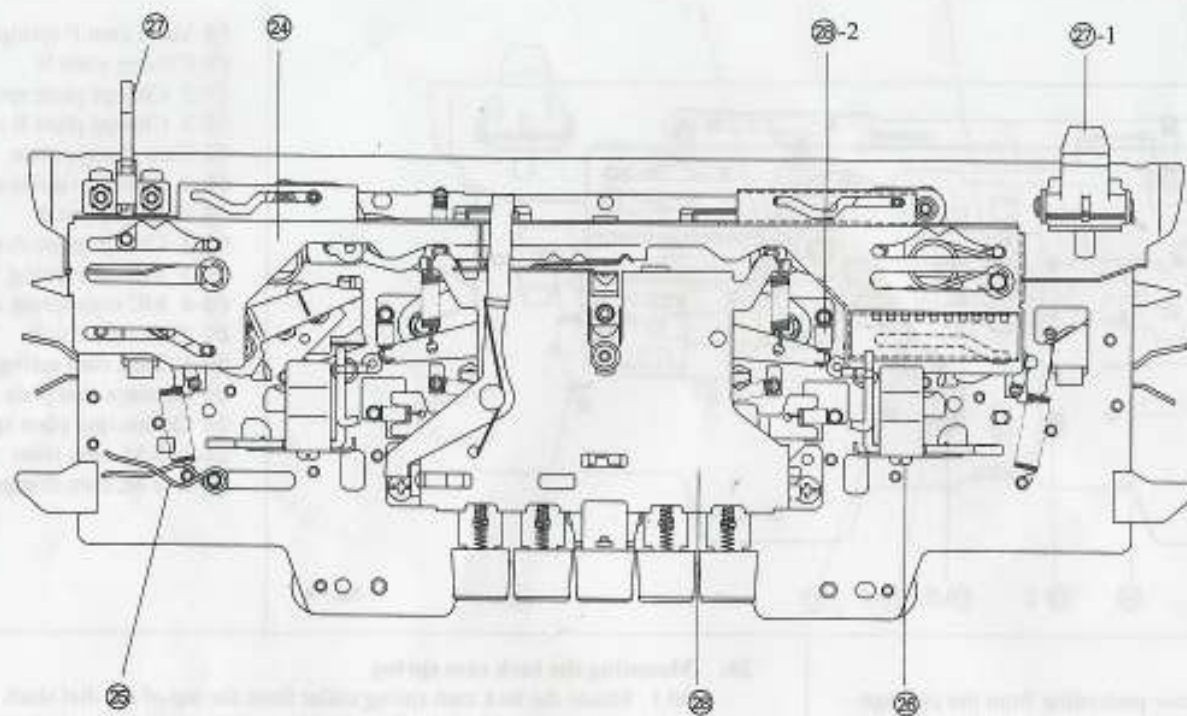

Part nomenclature

- 24 Upper slide plate
- 25 H.C.L. spring
- 26 Handle screw
- 27 Knit reader tripper
- 27-1 Row counter tripper
- 28 Cam button unit
- 28-2 Raising cam switch spring

Fig. 9-9

24. Mounting the upper slide plate

24.1 Mount the upper slide plate so that the calking pins of the carriage plate, the connecting plate pins, the cam change plate pins, and the pins of S.M. cam change crank, on both right and left sides, come into eight slots of the upper slide plate.

(Be sure to check the pins of needle selection lever are located before the upper slide plate.)

24.2 Fix the upper slide plate onto the carriage plate calking pin and the change knob shaft with a snap ring.

25. Mounting the H.C.L. spring

25.1 Insert the H.C.L. spring into the shaft of the upper slide plate and the screw.

26. Mounting the handle screws

26.1 Tighten the handle spring screws onto the handle setting base.

27. Mounting the knit reader tripper and row counter tripper

27.1 Place the knit reader tripper on the left and the row counter tripper on the right and tighten each of them from the rear side of the carriage with two screws.

28. Mounting the cam button unit

28.1 Mount the cam button unit to the stitch dial shaft and tighten the left and right sides with screws.

28.2 Hook the raising cam change spring to the raising cam calking pin.

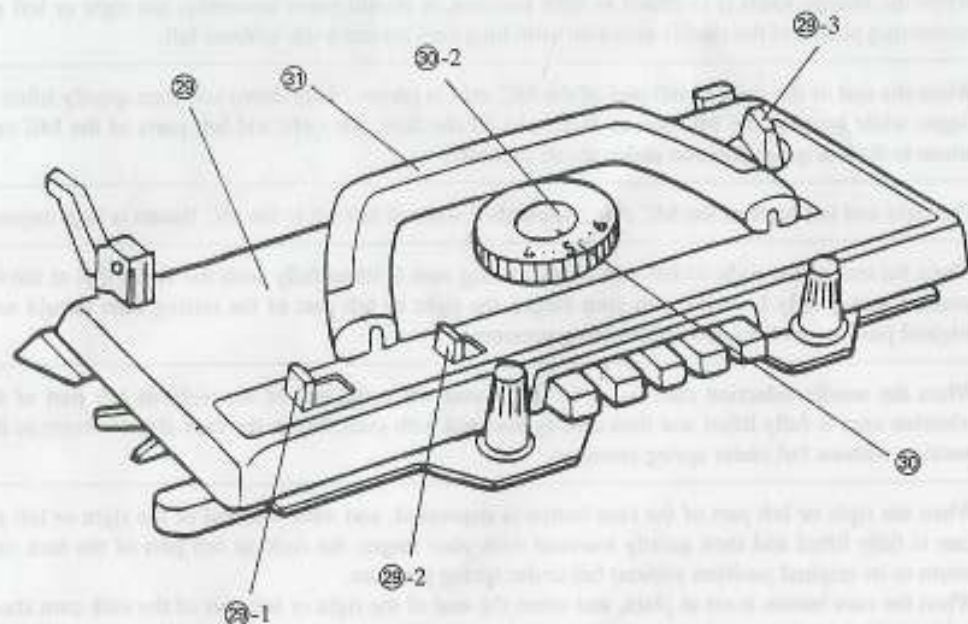

Part nomenclature

- ②⑨ Carriage cover
- ②⑨-1 H.C.L. knob
- ②⑨-2 Plain lever knob
- ②⑨-3 Change knob
- ③① Stitch dial
- ③①-2 Stitch dial cap
- ③① Carriage handle

Fig. 9-10

29. Mounting the carriage cover

- 29.1 Place the H.C.L. knob over the H.C.L. knob shaft.
- 29.2 Place the plain lever knob over the cam button unit.
- 29.3 Place the change knob over the change knob shaft (pay attention to the position).
- 29.4 Mount the carriage cover and tighten it down with screws (tapping screws) from the rear of the carriage.

30. Mounting the stitch dial

- 30.1 Fit the stitch dial on the shaft and tighten the screws in such a way that the notch in the stitch dial presser cap comes in front.
- 30.2 Bring the mark of the stitch dial presser cap to the notch in the knob retainer and put the cap in position. Align the line mark such that it is directly over the digits on the dial.

31. Mounting the carriage handle

- 31.1 Placing the handle in the down position, tighten it down on the left and right with screws.

10. CHECKING THE CARRIAGE FUNCTION

10.1 KH-864, 868 CHECKING THE CARRIAGE FUNCTIONS -1-

1. Change knob function	1.1 When the change knob is switched to each position, it should move smoothly; the right or left part of the connecting plate and the needle selection switching cam should work without fail.
2. MC cam operating	2.1 When the end of the right or left part of the MC cam is pressed fully down and then quietly lifted with your finger while keeping the MC button depressed all the time, the right and left parts of the MC cam should return to their original position under spring pressure.
3. MC knitting change cam operation	3.1 The right and left parts of the MC cam should shift without fail while the MC button is kept depressed.
4. Raising cam operation	4.1 When the end of the right or left part of the raising cam is lifted fully with the stitch dial at the 0, 5, or 10 position and quietly lowered with your finger, the right or left part of the raising cam should return to its original position without fail under spring pressure.
5. Needle selection cam operation	5.1 When the needle selection cam is set at "KC", and when the end of the right or left part of the needle selection cam is fully lifted and then quietly lowered with your finger, the cam should return to its original position without fail under spring pressure.
6. Tuck cam operation	6.1 When the right or left part of the cam button is depressed, and when the end of the right or left part of the cam is fully lifted and then quietly lowered with your finger, the right or left part of the tuck cam should return to its original position without fail under spring pressure. 6.2 When the cam button is set at plain, and when the end of the right or left part of the tuck cam should return to its original position without fail under spring pressure.
7. Cam button unit function	7.1 When the cam button shifted to "TUCK right and left," "MC", or "PART right and left," the button should move smoothly and the tuck cam, the MC cam and the raising cam should shift their places without fail.
8. Holding cam lever function	8.1 When the holding cam lever is shifted to "H" or "N", it should move smoothly and the holding cam should make accurate operation without fail.
9. Plain knitting lever function	9.1 When the plain knitting lever is thrown rightward while pressing "TUCK right and left," "MC" or "PART right and left" buttons, the lever should move smoothly and the cam button should return to its original position without fail.

10.2 KH-864, 868 CHECKING THE CARRIAGE FUNCTIONS -2-

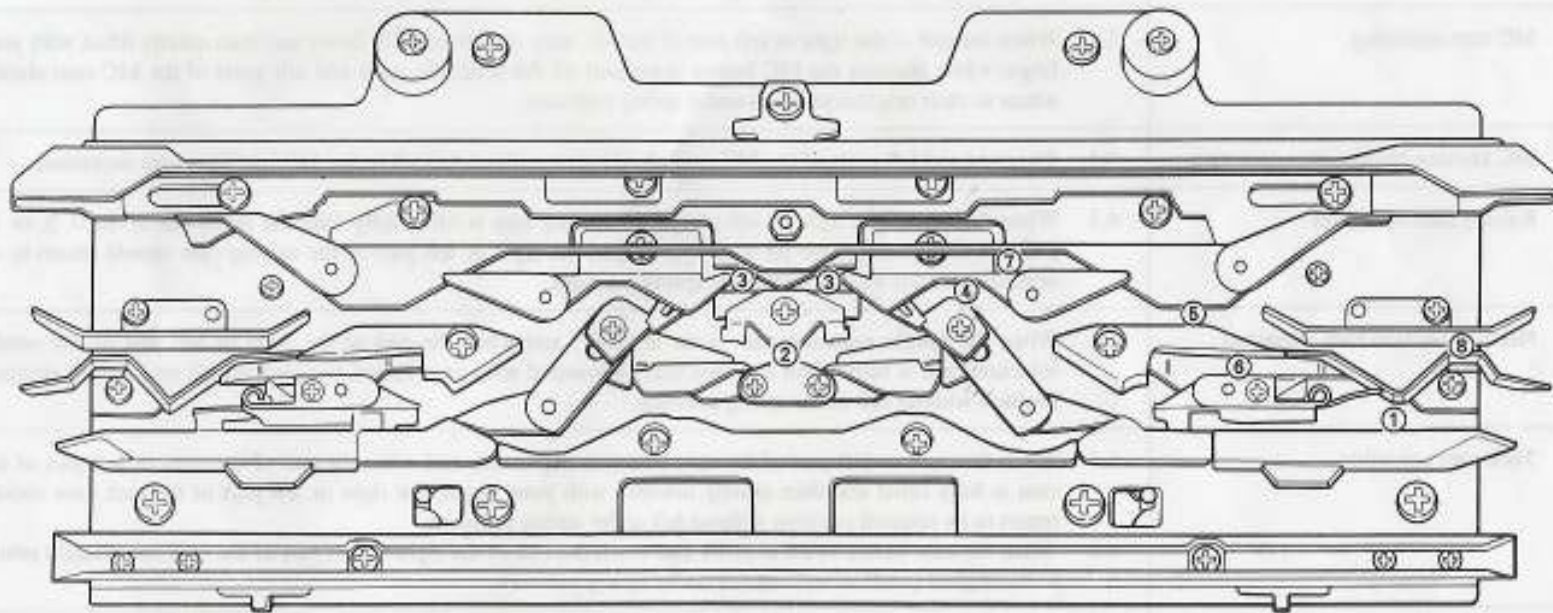

Fig. 10-1

Make sure that the needle butt passes smoothly through the following:

- | | |
|---|---|
| (1) Between the sub raising cam and the separating cam. | (5) Between guide cams A and D. |
| (2) Between the tuck cam plate and guide cam C. | (6) Between guide cam D and the needle selecting cam. |
| (3) Between guide cam C and slide cam. | (7) Between guide cams A and B. |
| (4) Between the sub raising cam and guide cam B. | (8) Between guide cam F and the separating cam. |

10.3 KH-894 CHECKING THE CARRIAGE FUNCTIONS -1-

1. Change knob function	1.1 When the change knob is switched to each position, it should move smoothly; the right or left part of the connecting plate and the needle selection switching cam should work without fail.
2. MC cam operating	2.1 When the end of the right or left part of the MC cam is pressed fully down and then quietly lifted with your finger while keeping the MC button depressed all the time, the right and left parts of the MC cam should return to their original position under spring pressure.
3. MC knitting change cam operation	3.1 The right and left parts of the MC cam should shift without fail while the MC button is kept depressed.
4. Raising cam operation	4.1 When the end of the right or left part of the raising cam is lifted fully with the stitch dial at the 0, 5, or 10 position and quietly lowered with your finger, the right or left part of the raising cam should return to its original position without fail under spring pressure.
5. Needle selection cam operation	5.1 When the needle selection cam is set at "KC", and when the end of the right or left part of the needle selection cam is fully lifted and then quietly lowered with your finger, the cam should return to its original position without fail under spring pressure.
6. Tuck cam operation	6.1 When the right or left part of the cam button is depressed, and when the end of the right or left part of the cam is fully lifted and then quietly lowered with your finger, the right or left part of the tuck cam should return to its original position without fail under spring pressure. 6.2 When the cam button is set at plain, and when the end of the right or left part of the tuck cam should return to its original position without fail under spring pressure.
7. Cam button unit function	7.1 When the cam button is shifted to "TUCK right and left," "MC", "L" or "PART right and left," the button should move smoothly and the tuck cam, the MC cam, the guide cam C and the raising cam should shift their places without fail.
8. Holding cam lever function	8.1 When the holding cam lever is shifted to "H" or "N", it should move smoothly and the holding cam should make accurate operation without fail.
9. Plain knitting lever function	9.1 When the plain knitting lever is thrown rightward while pressing "TUCK right and left," "MC", "L", or "PART right and left" buttons, the lever should move smoothly and the cam button should return to its original position without fail.

10.4 KH-894 CHECKING THE CARRIAGE FUNCTION -2-

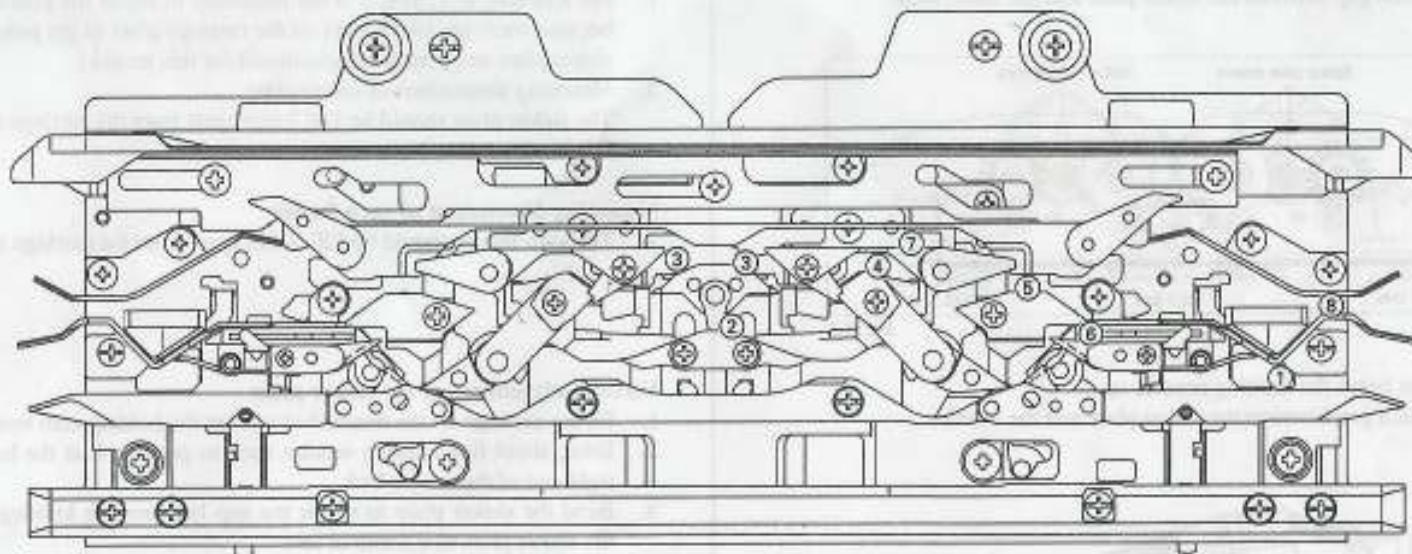

Fig. 10-2

Make sure that the needle butt passes smoothly through the following:

- | | |
|---|---|
| (1) Between the sub raising cam and the separating cam. | (5) Between guide cams A and D. |
| (2) Between the tuck cam plate and guide cam C. | (6) Between guide cam D and the needle selecting cam. |
| (3) Between guide cam C and slide cam. | (7) Between guide cams A and B. |
| (4) Between the sub raising cam and guide cam B. | (8) Between guide cam F and the separating cam. |

11. ADJUST THE CARRIAGE

1. The carriage does not move easily.
The fabric floats (stitch float).

HOW TO ADJUST THE CARRIAGE

Cause

Adjustment

1. The sinker plate is in touch with comb teeth.
There is too much gap between the sinker plate and the comb teeth.

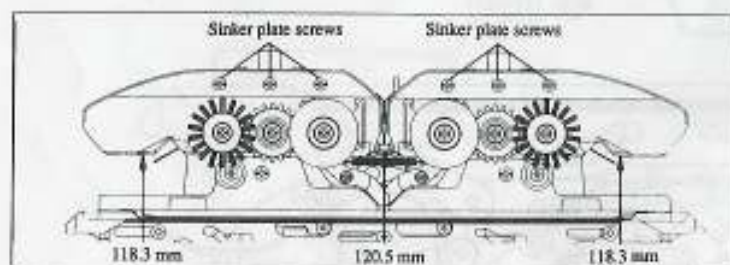

Fig. 11-1

2. The sinker plate keeps the knitting needles up.
There is too much gap between the sinker plate and the needle.

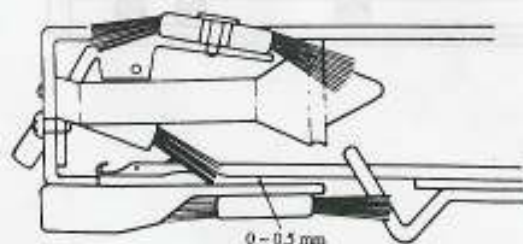

Fig. 11-2

Position adjustment of the sinker plate

1. For KH-864, 868, 894, it is not necessary to adjust the position of sinker plate because there are two bosses on the carriage plate to get proper position. (The sinker plate stoppers are discontinued for this model.)
2. Mounting dimensions of sinker plate
The sinker plate should be 118.3 mm apart from the carriage rear leg.
If it is not correct, loose screws and adjust.

Mounting dimensions of yarn feeder

1. The yarn feeder should be 120.5 mm apart from the carriage rear leg.

Vertical adjustment of the sinker plate

1. Fit the carriage on the needle bed and set the holding cam lever at "H".
2. Bring about five knitting needles each to position E at the left end, center and right end of the needle bed.
3. Bend the sinker plate to adjust the gap between the knitting needle stem and the sinker plate to 0.5 mm or less.

2. A lateral stripe is produced every second row (KH-864, 868)

Cause

1. The right and left parts of the stitch cam are positioned differently.

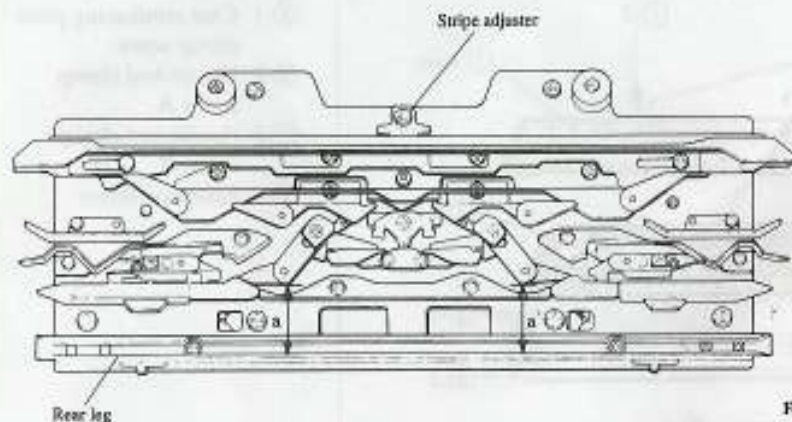

Fig. 11-3

Adjustment

- * The stripe adjusting plate is connected with the stitch cam, and the stitch cam guide plate is connected with the right and left stitch cams.
- Loosen the stripe adjusting plate clamp screw. Use slide calipers to adjust the stripe adjusting plate so that the length (at a and a') of the right and left parts of the stitch cam will become even. Then tighten the stripe adjusting plate clamp screw.
 Note: The length difference at the stitch cam (between a and a') should not exceed 0.35 mm.
 Hint: When the stitch dial is set at 5, the length at the stitch cam: 32.5 mm.
 - After the adjustment, be sure to check it by knitting plain stitch using a medium yarn and with the stitch dial set at 5.

3. The carriage refuses to go midway
The latch of the knitting needle is bent

1. Guide cam A is in wrong position.

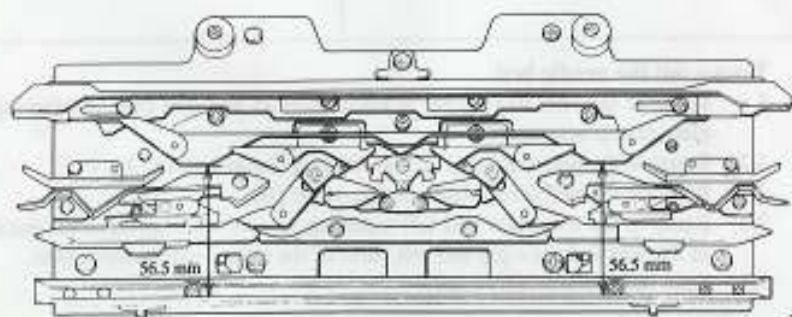
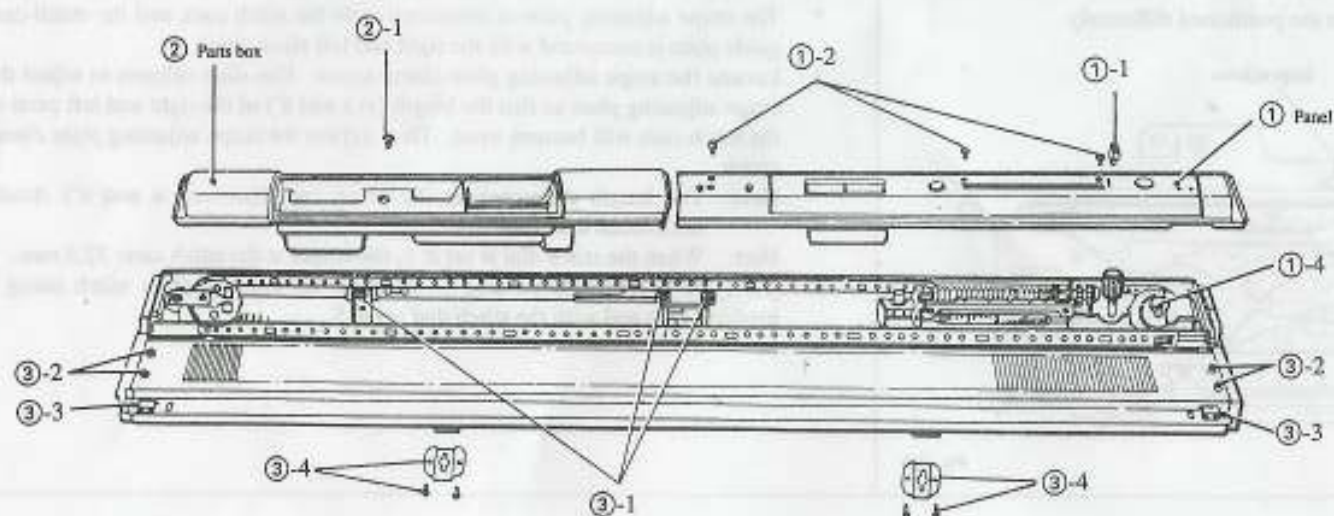

Fig. 11-4

Mounting dimensions of guide cam A.

- Loosen the right and left guide cam A clamp screws and the plate clamp nut. Clamp again after adjusting the distance between guide cam A and the carriage rear leg to 56.5 mm.
 (Fig. 11-4)
 Note 1: If guide cam A is not more than 56.5 mm apart from the rear leg, the gap between guide cams A and B will be too narrow for the knitting needle.
 Note 2: If the distance between guide cam A and the rear leg far exceeds 56.5 mm, the yarn guide might damage the latch.

12. DISASSEMBLING THE BED



Name of parts

- ①-1 Card stop lever knob
- ①-2 Needle selector panel clamp screw
- ①-4 Direction indicator
- ②-1 Parts box clamp screw
- ③-1 Case reinforcing plate clamp screw
- ③-2 Needle bed clamp screw A
- ③-3 Needle bed clamp screw B
- ③-4 Fastening screw

Fig. 12-1

1. Removing the needle selector panel

- 1.1 Lift and pull off the card stop lever knob.
- 1.2 Remove the three needle selector panel clamp screw.
- 1.3 Slide the panel to the right, lift and take it off.
- 1.4 Lift and pull off the direction indicator (plastics).

2. Removing the parts box

- 2.1 Remove the lid of the parts-box and take out the accessories. Remove one parts box clamp screw.
- 2.2 Slide the parts-box to the right; lift and take it off.

3. Taking out the needle bed

- 3.1 Remove the two stay center B clamp screws and one case reinforcing plate clamp screw.
- 3.2 Remove the four right and left needle bed clamp screws (A).
- 3.3 Remove the two needle bed clamp screws (B).
- 3.4 Remove the four right and left fastening screws working from the back of the bed and the right and left parts of the mount will become free.
- 3.5 Take the bed out of its case.

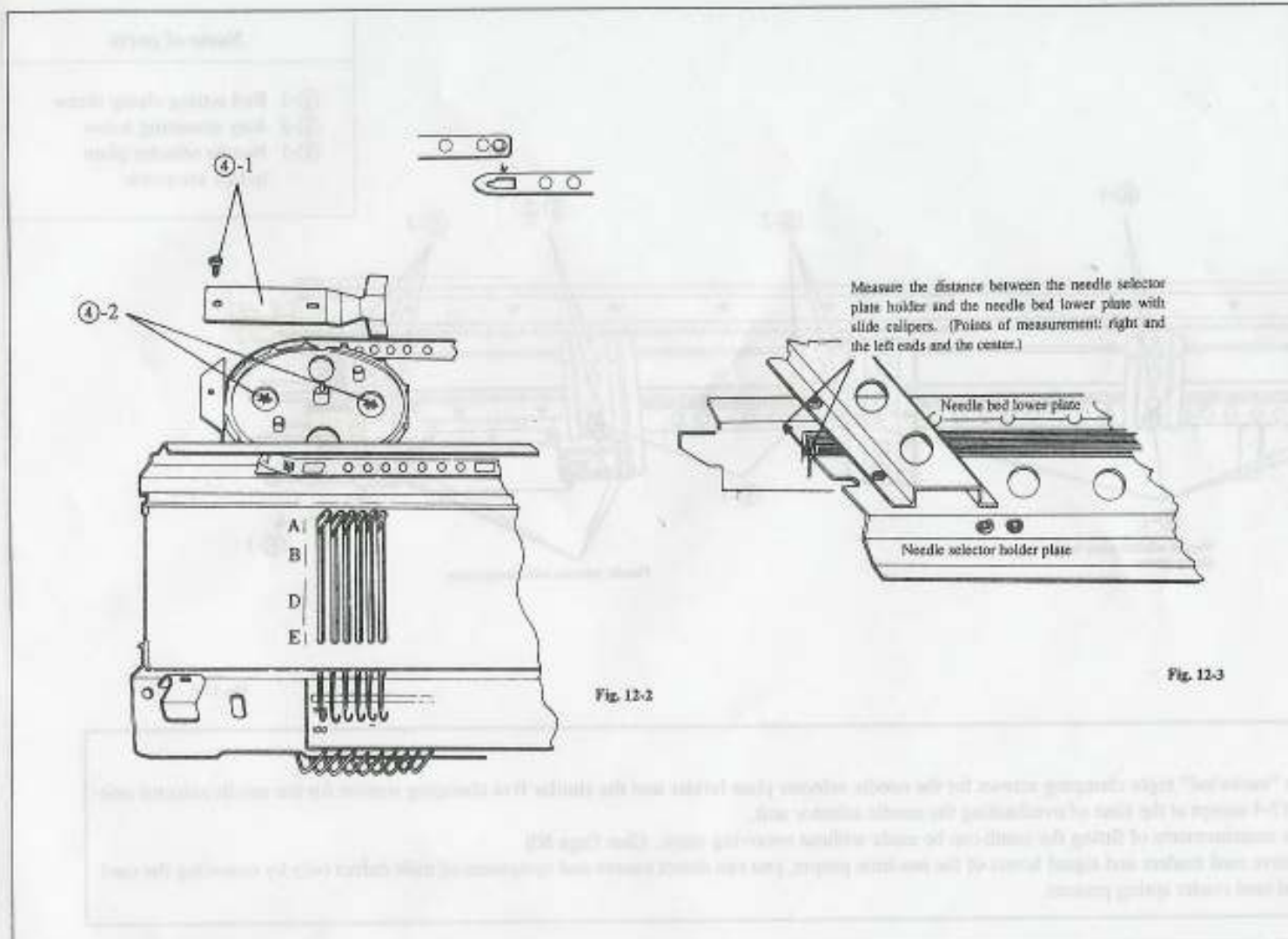

Name of parts	
④-1	Pulley leaf spring; pulley leaf spring clamp screw
④-2	Pulley bearing clamp screw

Fig. 12-2

Fig. 12-3

4. Removing the belt

- 4.1 Remove the pulley spring clamp screw and pull off the pulley spring.
- 4.2 Loosen the right and left pulley bearing clamp screws.
- 4.3 Remove the belt connecting pin and pull off the belt.
- 4.4 Take care not to lose the rubber washer on the pulley shaft.

Measurement of the distance between the needle selector plate holder and the needle bed lower plate.

Measure the above distance with slide calipers and jot down the result. When reassembling this section, see to it that the same distance will be reproduced.

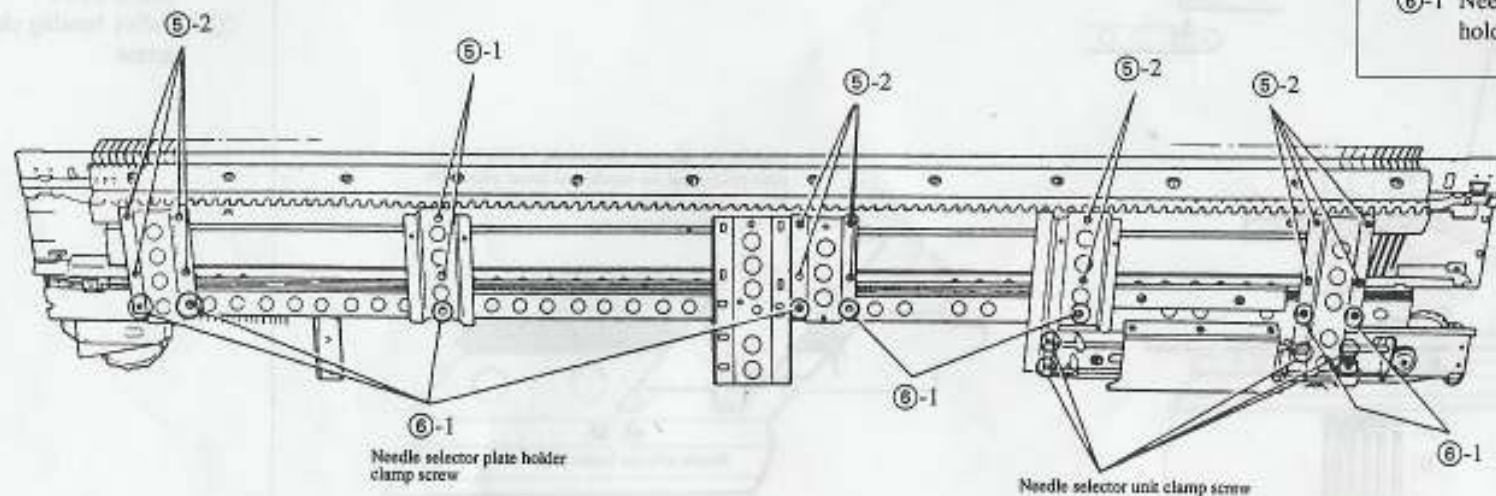

Name of parts

- ⑤-1 Bed setting clamp screw
- ⑤-2 Stay mounting screw
- ⑥-1 Needle selector plate holder set-screw

Fig. 12-4

Remarks:

1. Don't remove the "encircled" eight clamping screws for the needle selector plate holder and the similar five clamping screws for the needle selector unit shown in Figure 12-4 except at the time of overhauling the needle selector unit.
2. Adjustment of the measurements of fitting the comb can be made without removing stays. (See Page 50)
3. In repairing defective card readers and signal levers of the machine proper, you can detect causes and symptoms of their defect only by removing the card reader support and card reader spring presser.

5. **Removing the needle selector unit (with the needle selector plate holder)**
 - 5.1 Remove the two bed setting clamp screws.
 - 5.2 Remove the two stay center clamp screws, four left and right stay clamp screws, the needle selector unit and the needle selector plate holder will come off together.

6. **Removing the needle selector unit from the needle selector plate holder**
 - 6.1 Remove the needle selector unit clamp screws from the center and right parts of the stay, and the needle selector unit will come off the needle selector plate holder.
It will be also possible to pull out the 24 card signal levers.

13. DISASSEMBLING THE NEEDLE SELECTOR PLATE HOLDER

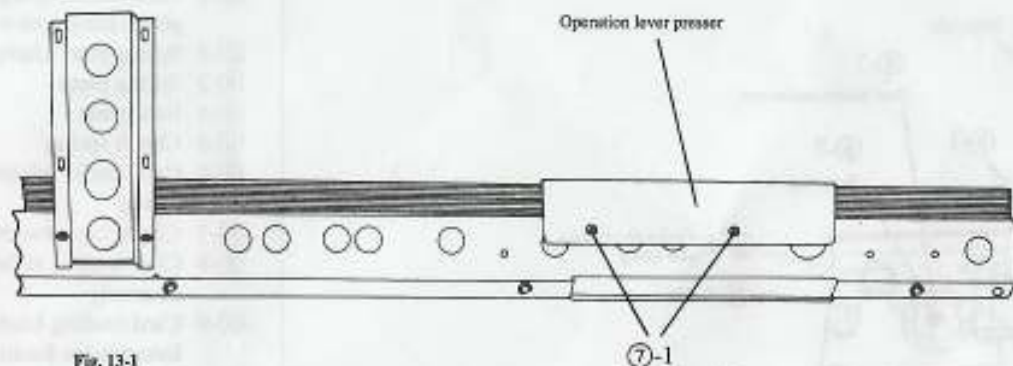

Fig. 13-1

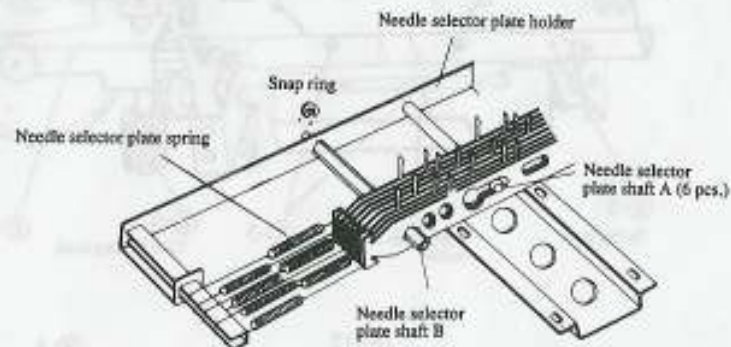
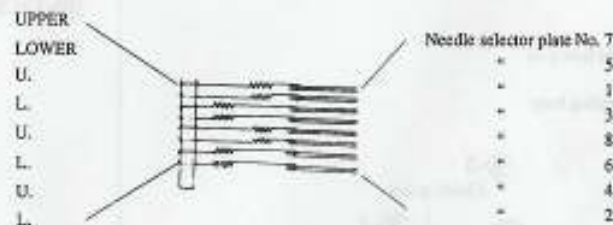

Fig. 13-2

7. Removing the needle selector plate holder.

- 7.1 Remove two screws securing the operation lever presser, and remove the operation lever presser.
- 7.2 Remove eight needle selector plate springs. (Before removing the springs, take note of their positions.)

- 7.3 Remove the E-shaped snap ring (2.5) from the needle selector plate shaft (square) on the rear of the needle selector plate holder, and remove the shaft.
- 7.4 While sliding the eight needle selector plates one by one to the right, remove them through slots in the needle selector plate shafts A (6 shafts).

Name of parts

- ⑦-1 Operation lever presser screw
- ⑦-2 Needle selector plate
- ⑦-3 E-shaped snap ring (2.5)

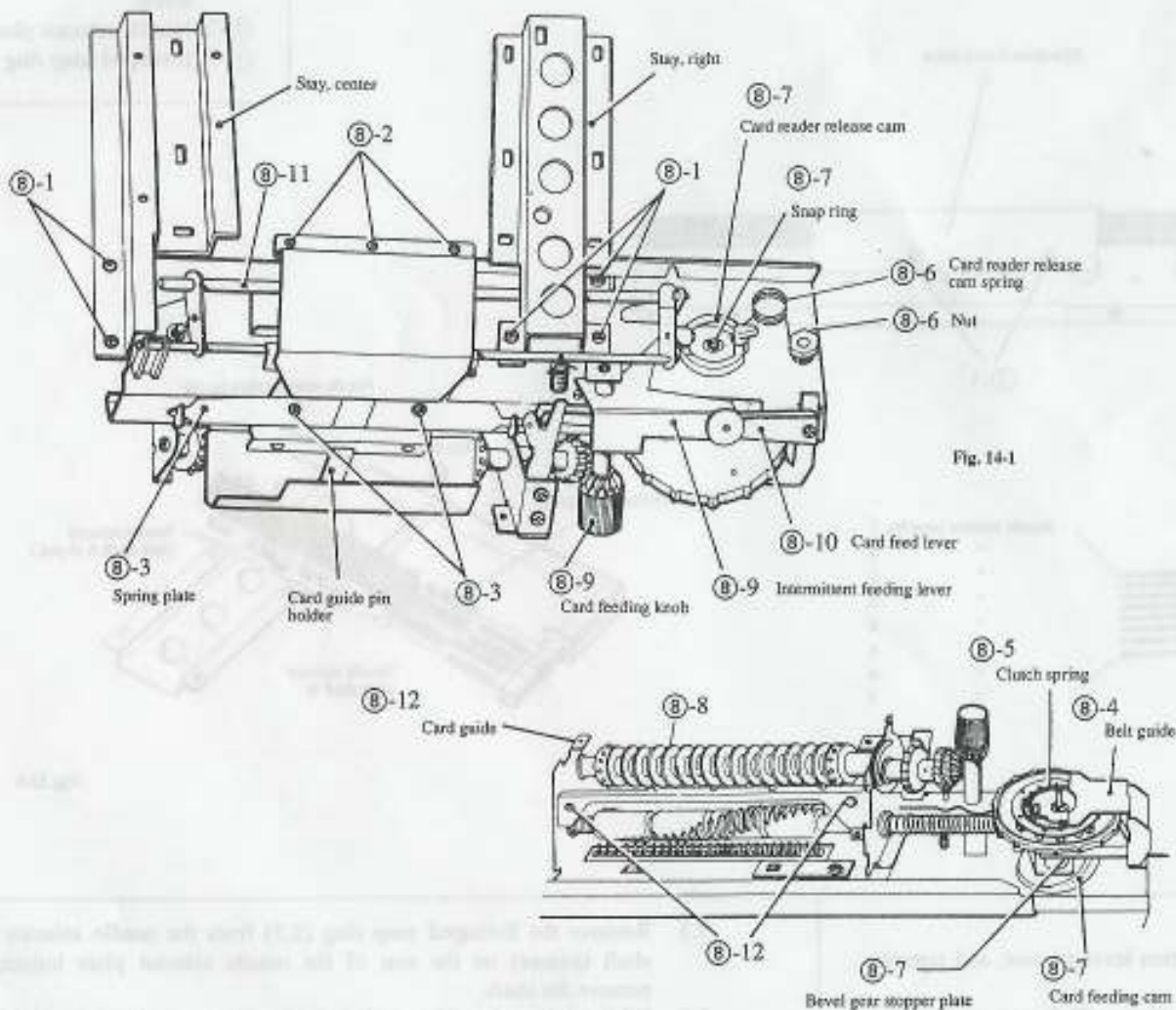

Fig. 14-1

Fig. 14-2

Name of parts

- ⑧-1 Needle selector unit clamp screw
- ⑧-2 Card reader spring presser plate clamp screw
- ⑧-3 Spring plate clamp screw
- ⑧-3 Spring plate
- ⑧-4 Belt guide
- ⑧-5 Clutch spring
- ⑧-6 Card reader release cam spring
- ⑧-7 Clutch cam assembly
- ⑧-8 Card feeding roller assembly
- ⑧-9 Card feeding knob
Intermittent feeding lever
- ⑧-10 Card feed lever
- ⑧-11 Card reader release spring
- ⑧-12 Card guide clamp screw

14. DISASSEMBLING THE NEEDLE SELECTOR UNIT

- 8.1 Remove five screws securing the needle selector units on the center stay and right stay, and remove both stays.
* When installing the center stay and right stay, they must be placed correctly in the original positions. Therefore, it is advisable to mark their positions on both stays with a slotted-head screwdriver.
- 8.2 Remove three screws securing the card reader spring presser plate, and the card reader spring presser plate and card reader spring can be removed.
- 8.3 Remove two screws securing the card reader holder plate, and pull it out toward you. (The card guide pin holder – made of plastic – can also be removed at the same time.)
Also 24 card readers can be pulled out.
- 8.4 Remove two screws (together with washers) on the belt guide plate (right), and pull out the belt guide plate to the right.
- 8.5 Remove the clutch spring.
- 8.6 Remove the nut and card reader release cam spring.
- 8.7 Remove the snap ring located under the clutch shaft fitted into the clutch wheel. Now the washer, card reader release cam, clutch wheel (set) and clutch cam A (shaft) can be removed. Also the card feed cam bevel gear stopper plate in the needle selector unit can be removed.
- 8.8 Remove the card feeding roller.
- 8.9 Remove the E-clip 2 located under the card feed knob, and the card feed knob shaft can be pulled out upward. Also the intermittent feeding lever, change lever, intermittent feeding lever spring and card feed knob lock cam can be pulled out upward.
- 8.10 Remove the step screw from the card feed lever, and the card feed lever can be removed. Also the card feed adjusting plate can be pulled out.

- 8.11 Remove the card reader release spring from the side of card reader release shaft.
- 8.12 Remove two screws (right and left) securing the card guide. The card feed base (left) can be pulled out to the left, and the right one can be pulled out to the right.

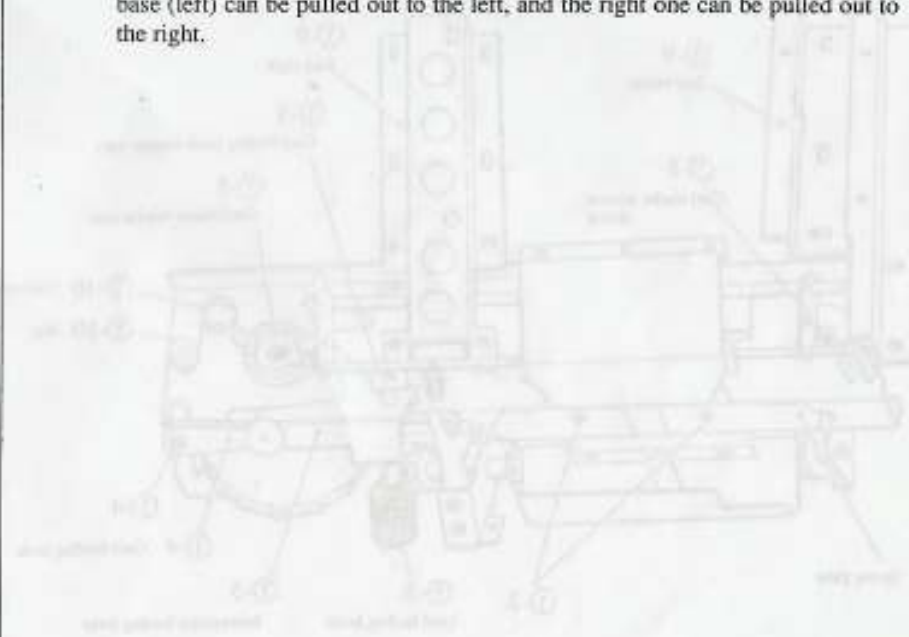

15. ASSEMBLING THE NEEDLE SELECTOR UNIT

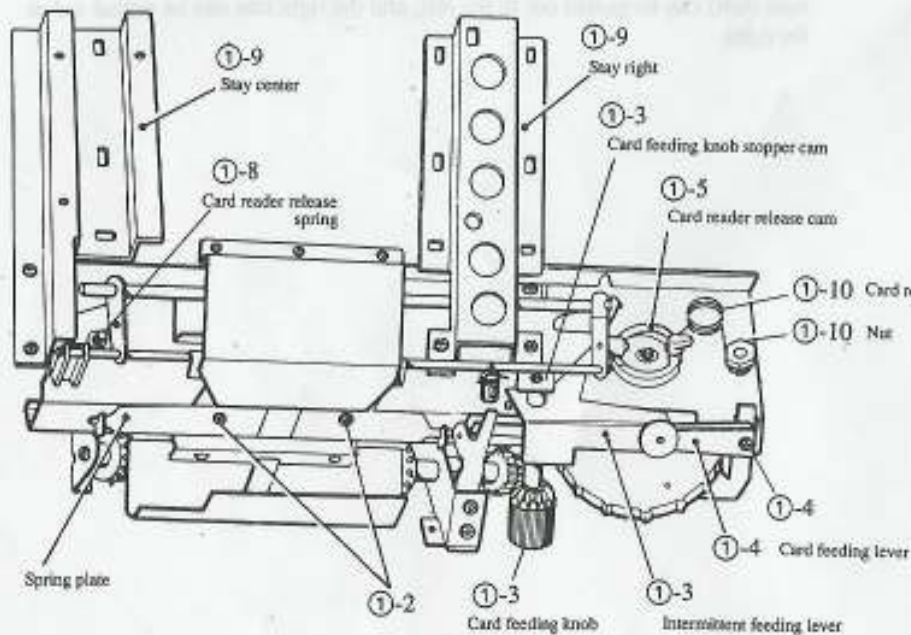

Fig. 15-1

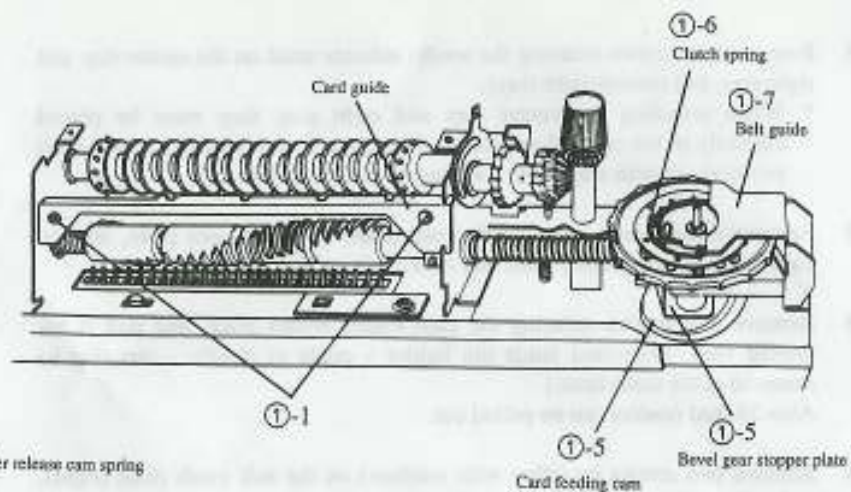

Fig. 15-2

How to adjust the Rotary cam and Clutch wheel

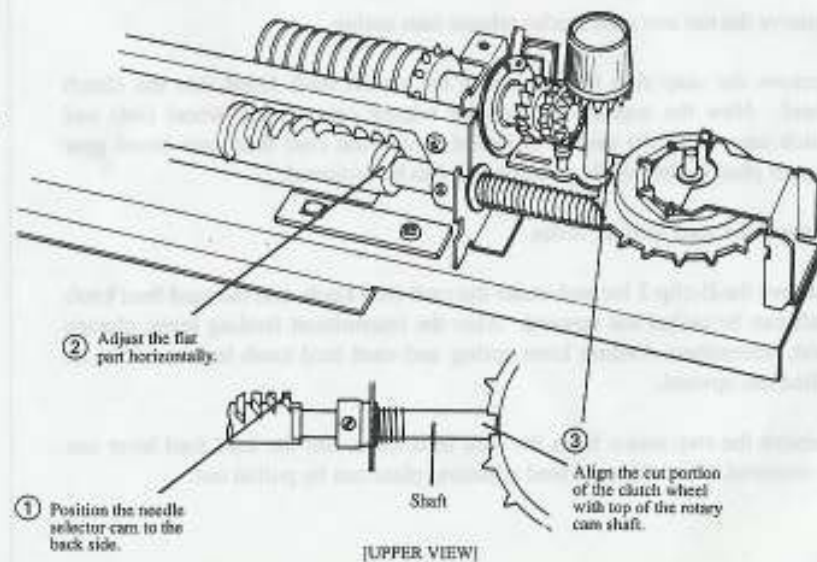

Fig. 15-3

1.1 Insert the card guide between the card roller and rotary cam from the left side, and insert the card roller shaft and rotary cam into two holes in the card feed base. Then lock the card feed bases, right and left, with card guide mounting screws.

* Clearance between the card roller and card guide should equal the total thickness 0.6 mm of three punch cards.

1.2 Insert the card roller unit into the needle selector unit. It is necessary to hook the ratchet onto the card feed stopper plate on the card feed base (right). Next, lock the card feed bases, right and left, to the rear of the needle selector unit by means of spring plate and clamp screws temporarily.

1.3 Insert the card feed knob stopper cam into the needle selector unit from underside, then fix the intermittent feeding lever, change lever and spring. Insert the card feeding knob shaft into the card feed knob stopper cam, intermittent feeding lever and change lever from top of the needle selector unit.

1.4 Insert the card feed adjusting plate into the needle selector unit, and secure the card feed lever with step screws.
Make sure that the intermittent feeding lever should go between the card feeding lever and round plate.
(Please refer to Fig. 20-7 on page 55.)

1.5 Insert the card feed cam and bevel gear stopper plate into the needle selector unit from the right side, and insert the clutch wheel and clutch cam A into the needle selector unit from its top. **(Align the cut portion of the clutch wheel with top of the needle selector plate cam, and position the needle selector cam so that the cam lobes are on the other side and the flat portion is in a horizontal position. Then mesh the bevel gears. Refer to the figure on the right on page 42.)** Next, pass the clutch cam A between the card feed cam lobes, and place the card reader return cam from the bottom side of the needle selector unit, and lock with washer and E-shaped stopper ring 2.5.

1.6 Install the clutch spring.

1.7 Insert the belt guide plate (right) into the needle selector unit from the right side, and lock with screws (with washers).

1.8 Install the card reader release spring.

1.9 Install the center stay and right stay in the positions (marked on the needle selector unit with a slotted-head screw driver when disassembled), and secure with screws (with washers).

1.10 Install the card reader release cam spring and fasten the nut.

Card feed lever adjustment

Turn clutch cam A in either direction so that the card feed cam pushes the card feed lever upward. Then push down the right side of the card feed lever until the ratchet begins to move, and lock with step screw.



16. ASSEMBLING THE NEEDLE SELECTOR PLATE HOLDER

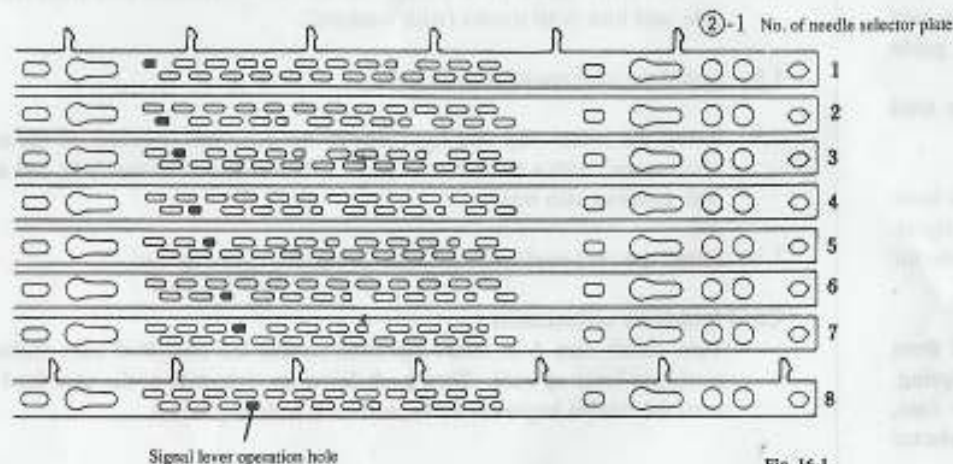

Fig. 16-1

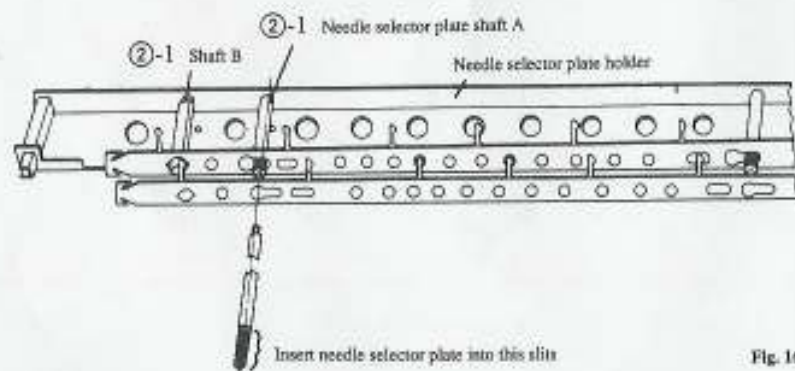

Fig. 16-2

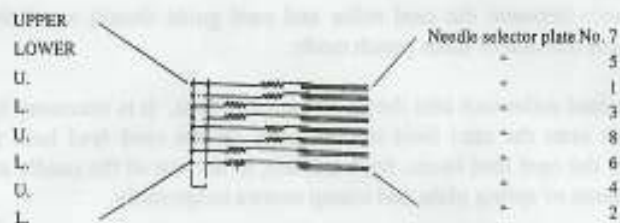

Fig. 16-3

2.1 Install the needle selector plates on the needle selector plate holder in the order of 7, 5, 1, 3, 8, 6, 4 and 2. Align the needle selector plates with the slits of needle selector plate shafts A (6 pieces), then insert the needle selector plate shafts B and secure with E-shaped snap ring.

2.3 Hook eight needle selector plate springs on spring hooks as illustrated above Fig. 16-3.

Springs should be hooked on to the lower part of needle selector plates, 5, 3, 6 and 2 and on to the upper of needle selector plates, 7, 1, 8 and 4. In other words, springs are positioned up and down alternately.

17. ASSEMBLING THE NEEDLE SELECTOR UNIT IN THE NEEDLE PLATE HOLDER

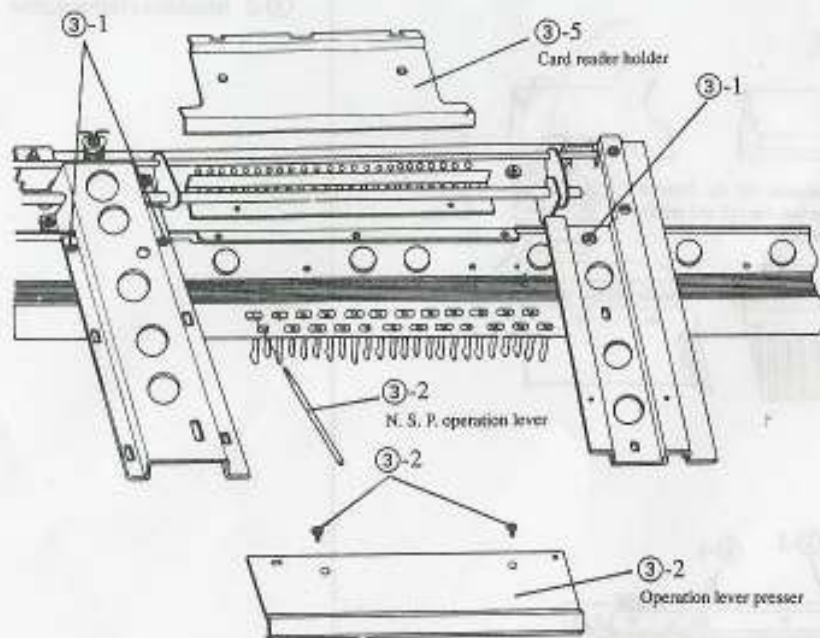

Fig. 17-1

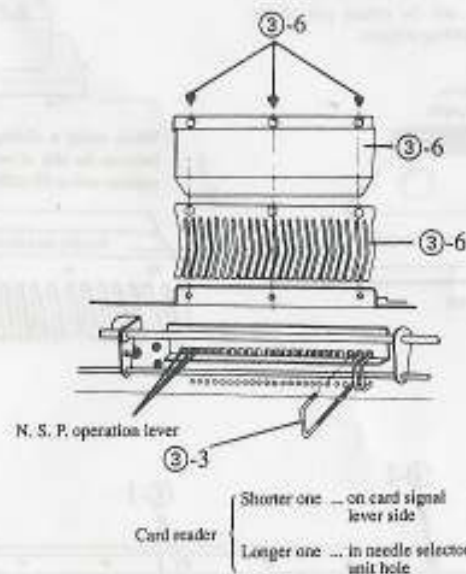

Fig. 17-2

Name of parts

- ③-1 Needle selector unit clamp screw
- ③-2 Operation lever presser clamp screw
- ③-3 Card reader
- ③-5 Card reader holder
- ③-6 Card reader spring
- Card reader spring presser plate

- 3.1 Install the needle selector unit in the needle selector plate holder, and tighten three needle selector unit clamp screws of the center stay and right stay.
- 3.2 Insert twenty four N.S.P. operation levers from the needle selector plate side, in the order of smaller ends. Install the operation lever presser, and secure with two screws.
- 3.3 Hold the needle selector unit with the reverse side front, and insert 24 card readers into the needle selector unit. Be sure to place the card reader is on the right side of the N.S.P. operation lever.
- 3.4 Remove the screws which was secured temporarily at the step 1.2 and remove the spring plates.
- 3.5 Fit the card guide pin holder (plastic) to the card reader holder plate, and

- insert right and left spring plates into the tab of the card roller holder right and left. Then secure with two screws.
- 3.6 Place the card reader spring so that the card reader is positioned under the center of the card reader spring, and hold down the spring with the card reader spring holder. Then secure with three screws.

Installation position of operation lever presser

Allow a clearance (0.1 ~ 0.3 mm) between operation lever presser and needle selector plate 2.

Take care so that needle selector plate 2 is not forced by operation lever presser.

18. ASSEMBLING THE NEEDLE SELECTOR PLATE HOLDER IN THE BODY

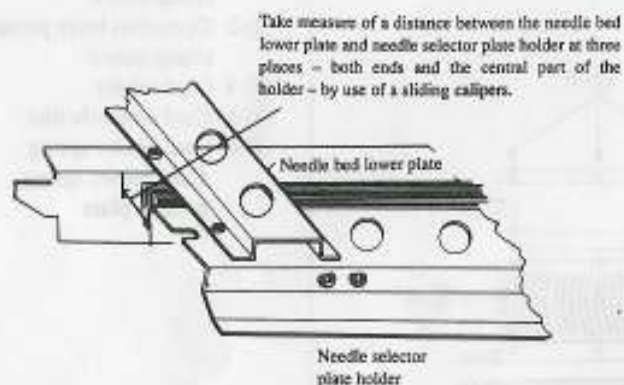

Fig. 18-1

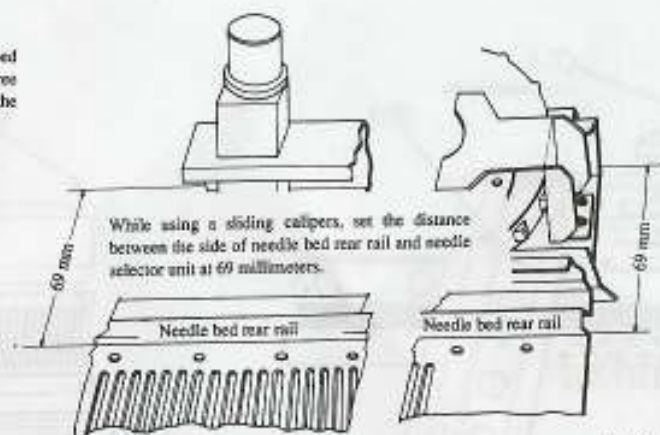
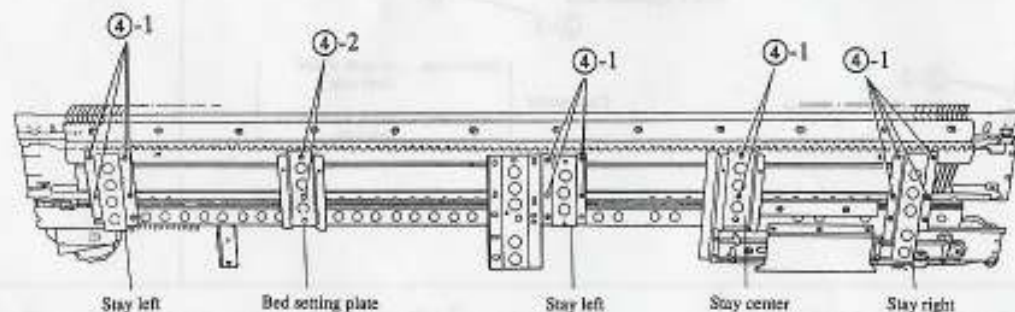

Fig. 18-2



Name of parts

- ④-1 Stay fitting screw
- ④-2 Machine clamp screw

- 4.1 Set the needle selector unit to the machine body and fasten with four clamp screws for the left, central and right stays each and two clamp screws for bed setting plate temporarily and after making adjustments mentioned below, fasten the needle selector formally.

Fitting of the needle selector plate holder

Fit the needle selector plate holder according to the measurement made with a sliding calipers as described in Figure 18-1.

Fitting of the needle selector unit

Fit the needle selector unit so that the distance between the unit and the side of needle bed rear rail come to 69 millimeters.

5. Mounting the belt

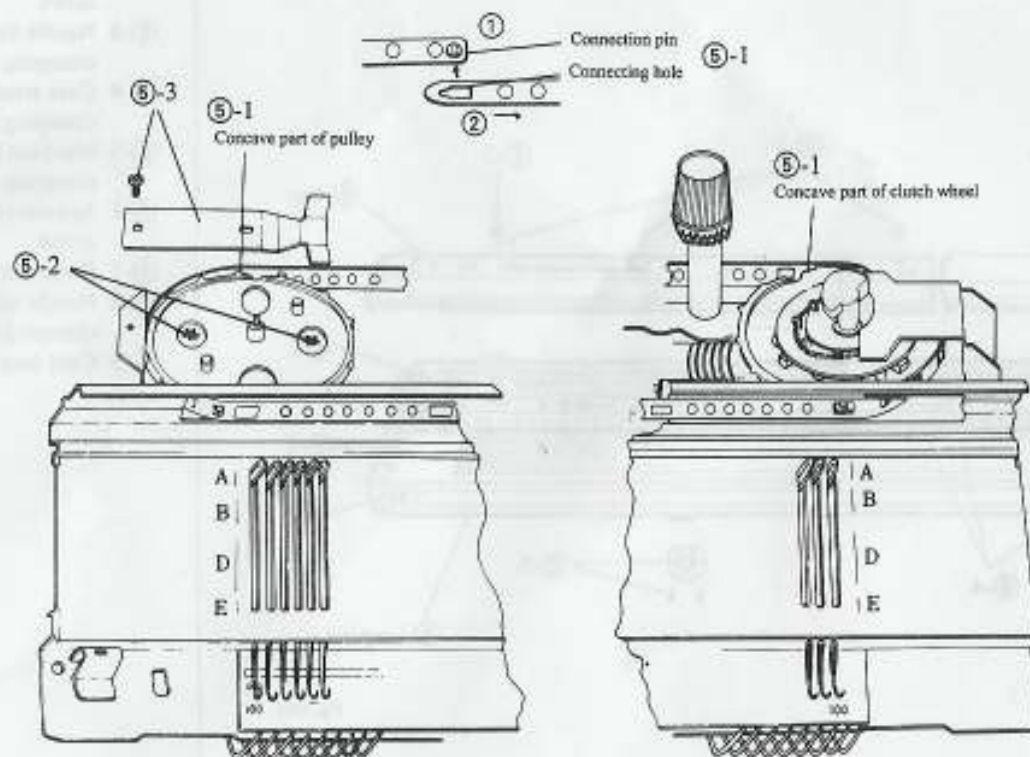

Fig. 18-3

Name of parts

- ③-2 Pulley shaft support clamp screw
- ③-3 Pulley leaf spring binding screw

5.1 With push button being kept down, pass the belt at once. Fit the belt so as to make the connecting pin face inside.

1. On the side of the pulley, pass the belt from your side by fitting the belt connecting pin into the concave part of the pulley.
2. On the side of the clutch wheel, pass the belt from your side by

fitting the belt connecting hole into the concave part of the clutch wheel to connect both ends of the belt with each other.

- 5.2 Stretch the belt to such an extent as there is no slack and tighten right and left clamping screw for the pulley shaft support.
- 5.3 Put the pulley spring in the pulley shaft and fasten with the binding screw.

6. Mounting the machine body into the case 7. Mounting the accessories box 8. Mounting the needle selector panel

Name of parts

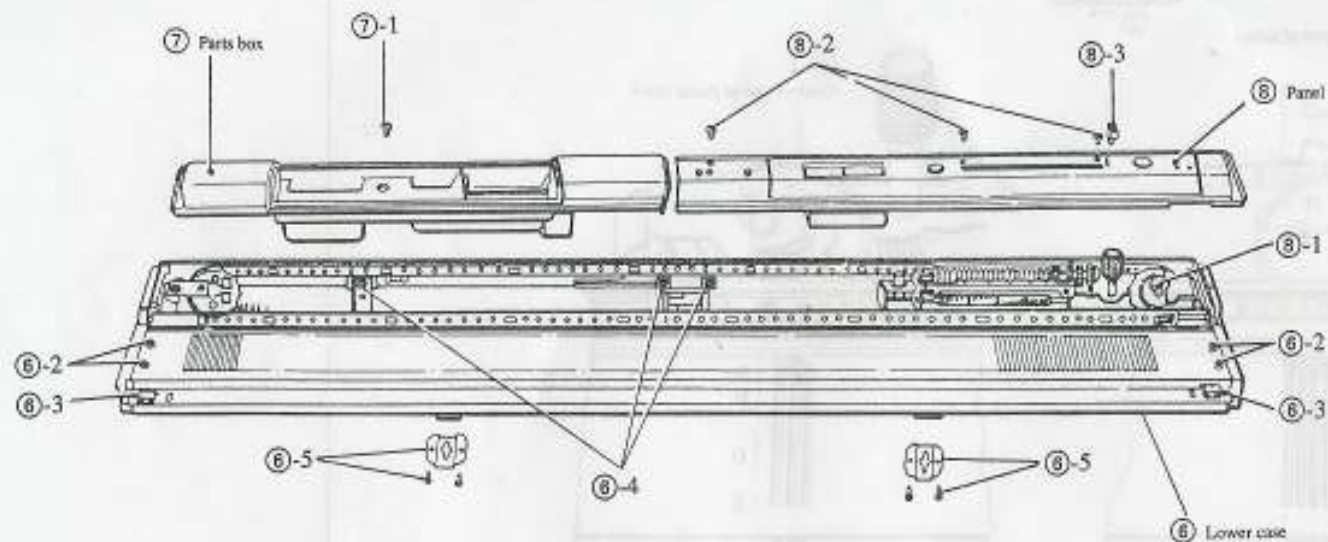

- ⑥-2 Needle bed clamping screw
- ⑥-3 Needle bed upper plate clamping screw
- ⑥-4 Case reinforcing plate clamping screw
- ⑥-5 Machine body fitting plate clamping screw
- ⑦-1 Accessories box clamping screw
- ⑧-1 Direction indicator
- ⑧-2 Needle selector panel clamping screw
- ⑧-3 Card stop lever knob

Fig. 18-4

- 6.1 Keep the machine body in the case. Left part is first.
- 6.2 Tighten two right clamping screws and the equal number of left clamping screw for the needle bed.
- 6.3 Put the right and left leaf springs in position of the needle bed upper plate and fasten with needle bed upper plate clamping screws.
- 6.4 Tighten three clamping screws for the case reinforcing plate and stay center B.
- 6.5 Fit the right and left machine body fitting plates onto the back side of the case with two clamping screws for right and left fitting plates each.

- 7.1 Keep the accessories box at the left side of the machine body and fasten with clamping screws.
- 8.1 Insert the direction indicator (plastic-made) into the clutch wheel shaft.
- 8.2 Keep the needle selector panel at the right side of the machine body and fasten with three needle selector panel clamping screws.
- 8.3 Insert the card stop lever knob into the lever.

19. INSPECTION OF NEEDLE SELECTOR FUNCTIONS

Function	Standards	How to check
Hand-operated card feeding	<ol style="list-style-type: none"> 1. That if the card feed knob is pushed down, then the gear will be engaged. 2. That when the card feed knob is pushed down, card readers come off completely from cards and the rotary cam. 3. That the card feed knob turns smoothly. 4. That click stop of the card roller shaft functions accurately. 	<ol style="list-style-type: none"> 1. Make sure by pushing down the card feed knob. 2. Make sure at the same time that you make sure of (1). 3. Insert the card and see if it is fed. 4. Make sure at the same time that you make sure of (3).
Automatic card feeding & clutch function at a time when rotation direction of clutch wheel is changed.	<ol style="list-style-type: none"> 1. That card readers come off completely from the card roller and rotary cam. 2. That the feed of card roller by means of the latchet is made accurately. 3. That after the above-mentioned actions, the clutch wheel gets into free rotation. 4. That the clutch wheel turns smoothly. 	<ol style="list-style-type: none"> 1. Make sure of (1) ~ (4) by turning the clutch wheel by hand. (Tactile impression and visual observation.)
Switching of card stop lever	<ol style="list-style-type: none"> 1. That the card stop lever can be switched smoothly. 	<ol style="list-style-type: none"> 1. Make sure by switching the card stop lever by hand.
Engaging of clutch wheel and rotary cam	<ol style="list-style-type: none"> 1. That the clutch wheel and rotary cam are engaged with each other in a correct position. 	<ol style="list-style-type: none"> 1. Visual observation.

20. ADJUST THE MACHINE BODY

1. Right and left fabric gauges are uneven; length of knitted fabric differs at both ends

HOW TO ADJUST THE MACHINE BODY

1. Fitting measurements of right and left combs are uneven.
(How to make fitting measurements of combs)

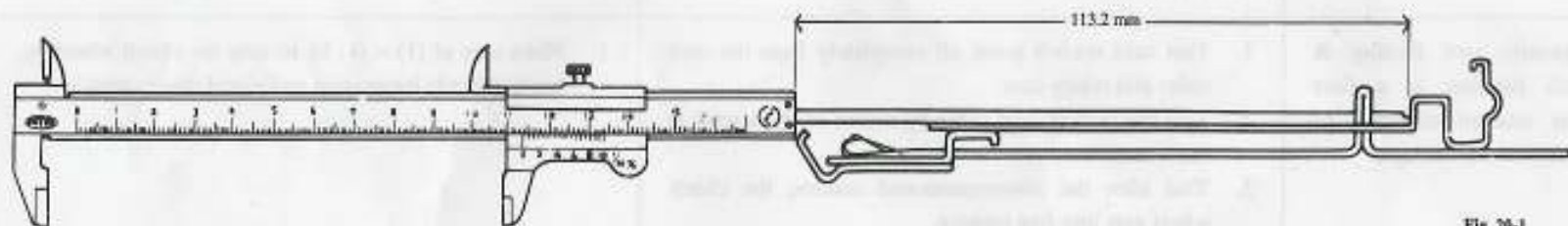

Fig. 20-1

Cause

How to adjust

1. Take out the machine body from the case. (See page 36)
2. Loosen 8 clamping screws for needle bed comb on the stay right, center and left and lower holder plate. (See on page 38)
3. Loosen 12 clamping nuts on the back side of combs with a wrench.
4. Put out three needles each at both ends and in the central part of the needle bed and determine a position of combs so as to let needles come to midway between both combs. (Bilateral adjustment)
5. Set fitting measurement of combs at 113.2 millimeters at both ends and in the central part of the machine body and fasten with clamping nuts. (Longitudinal adjustment)

(In this case, keep it in mind that if such nuts are tightened too hard, screws will be twisted off.)

(Adjust measurement of fitting combs by use of a sliding calipers and fasten with clamping nuts.)

6. After making such adjustments, don't fail to knit 30 rows in plain stitch with the stitch adjusting dial set on "5", 200 stitches and by using medium yarn and then measure the length of fabric at the 78th stitch each from center. Make sure that a difference in length between right and left measurements is less than three millimeters. (Apply a load of 1 kilogram, on the average, to fabric. For the 1 kg load is suitable the use of about four claw weights on the cast-on comb long.)

2. Needles come to move lightly in part

1. Needle retaining spring is broken

Cause

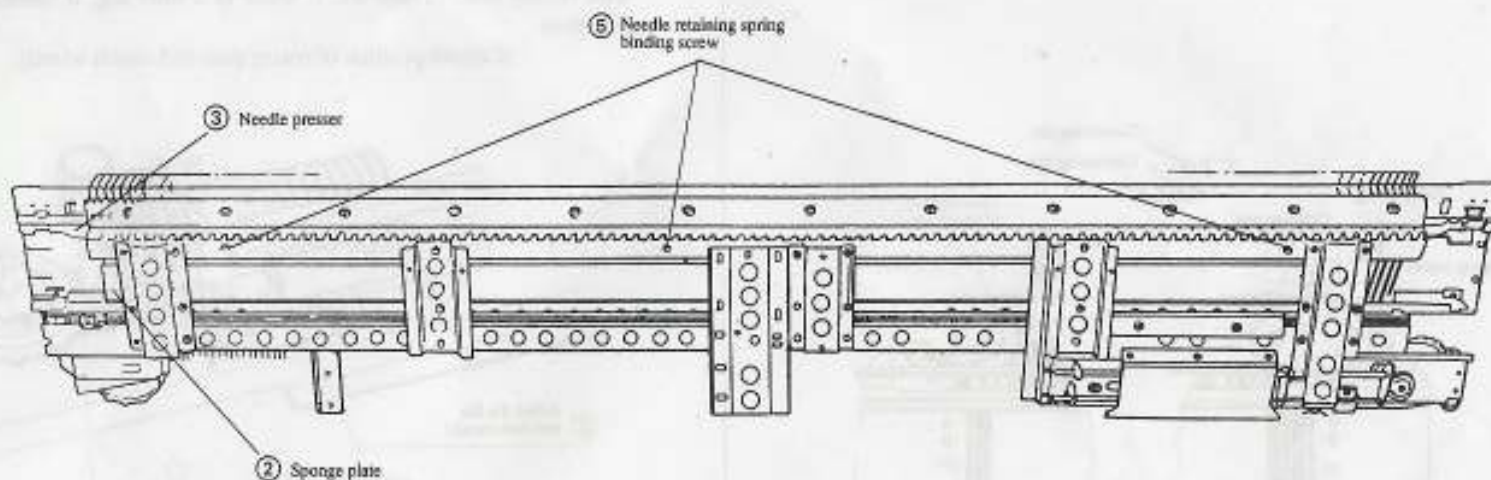

Fig. 20-2

How to adjust

Removing the needle retaining spring

1. Take out the machine body from the case (See Page 36).
2. Pull out the sponge bar.
3. Pull out the needle presser.
4. Bring forward the plain needles to E-position.
5. Remove three binding screws for the needle retaining spring on the comb and the needle retaining spring will come off.
6. Remove the needle retaining spring from the comb, and pull out the spring.

Fitting the needle retaining spring

1. Fit the needle retaining spring onto the comb and fasten the needle retaining spring on comb with three binding screws for the needle retaining spring.
2. Bring back the needles to B-position.
3. Put the needle presser.
4. Put the sponge bar.
5. Keep the machine body in the case. (See Page 48)

3. Needle selection is not correct

(Cause 1)

Mounting of Timing belt, Clutch wheel and pulley is not correct.

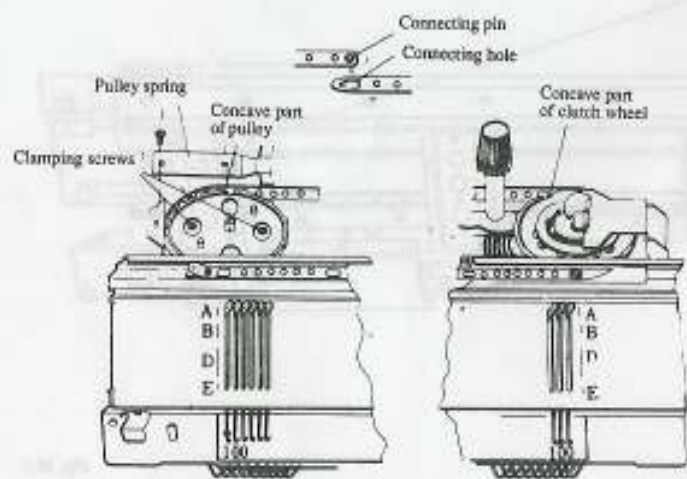

Fig. 20-3

(Cause 2)

Mounting of rotary cam or clutch wheel is not correct.

The carriage movement is synchronized with the needle selection mechanism with timing belt. Therefore, if there is a time lag, it causes wrong needle selection.

(Correct position of rotary cam and clutch wheel)

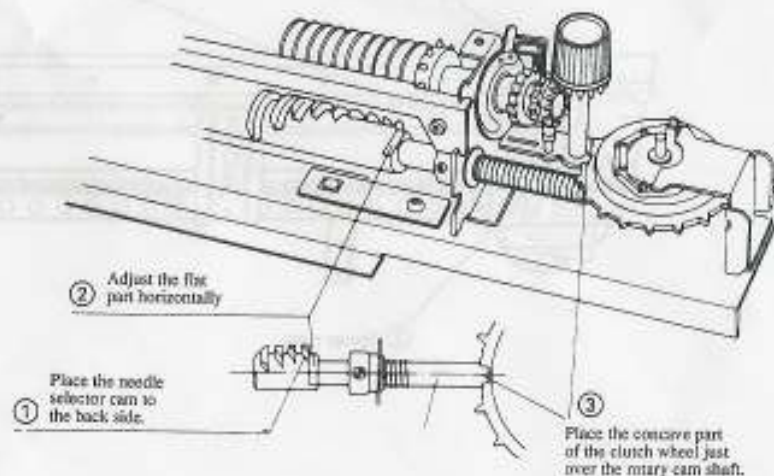

(Upper view)

Fig. 20-4

(Check the position)

When the flat part of rotary cam is placed horizontally, the concave part of clutch wheel must be just over the rotary cam shaft.

Cause

How to adjust

The connecting part of timing belt must fit both concave parts of pulley and clutch wheel.
(See on page 47 to adjust.)

- 2.1 Remove the timing belt and belt guide plate of the clutch wheel.
- 2.2 Remove the snap ring for clutch wheel shaft from back side and remove the card feeding cam and card reader release cam.
- 2.3 Pull up the clutch wheel a little, and turn the clutch wheel to get correct position.

Cause

(Cause 3)

Mounting of card reader guide plate is not correct.
Position of rotary cam is not correct.

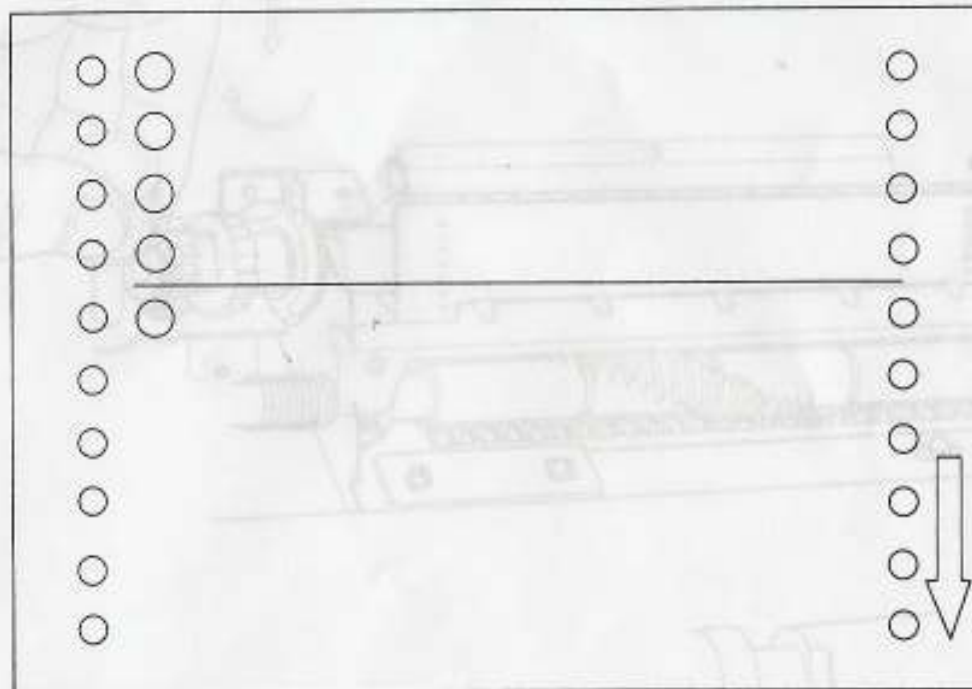

Fig. 20-5

How to adjust

3.1 Make the punch card for checking as illustrated.

Cause

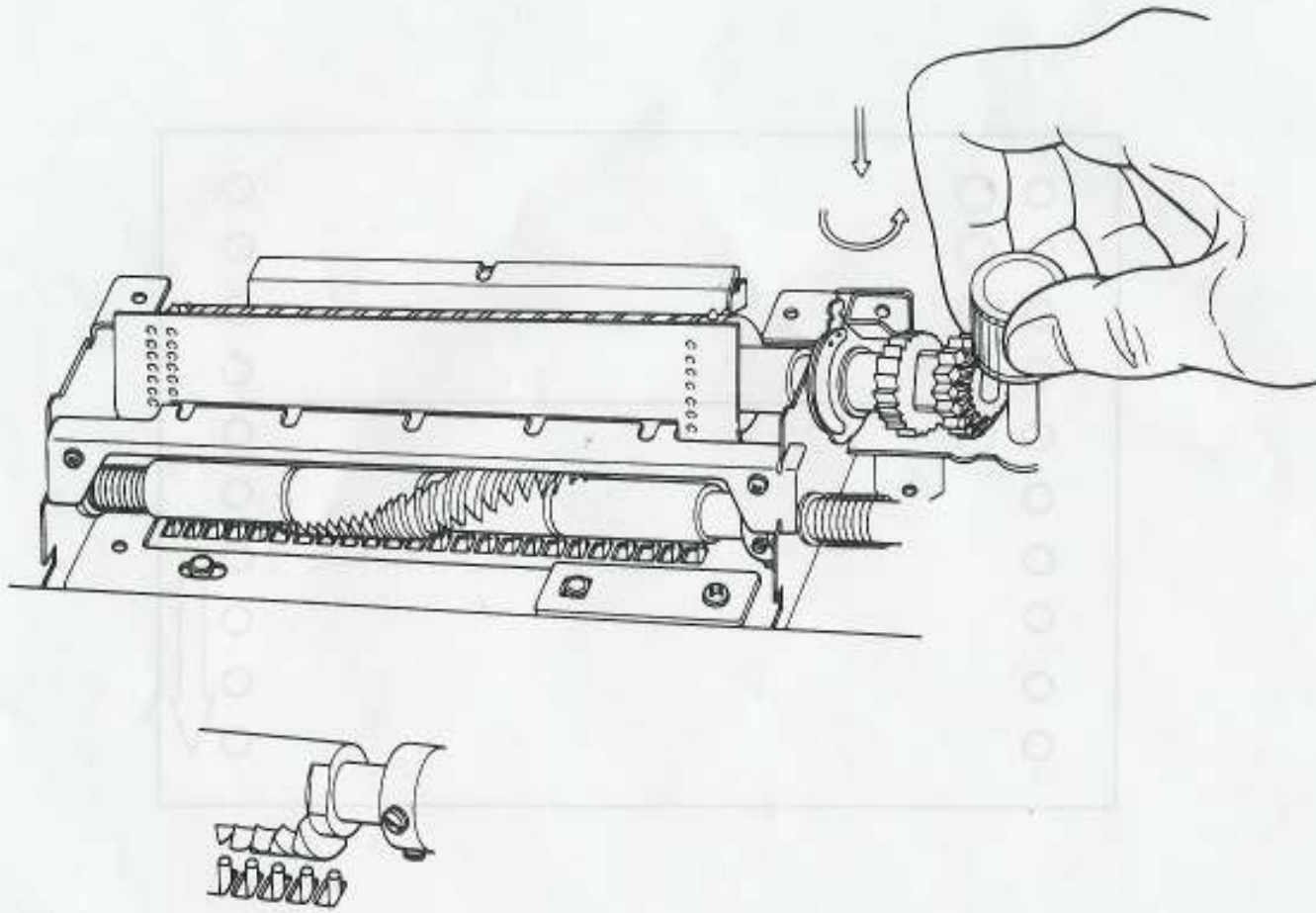

Fig. 20-6

How to adjust

- 3.2 Insert the checking punch card and set the starting line. Confirm that all card readers are not in contact with any position of rotary cam.

Cause

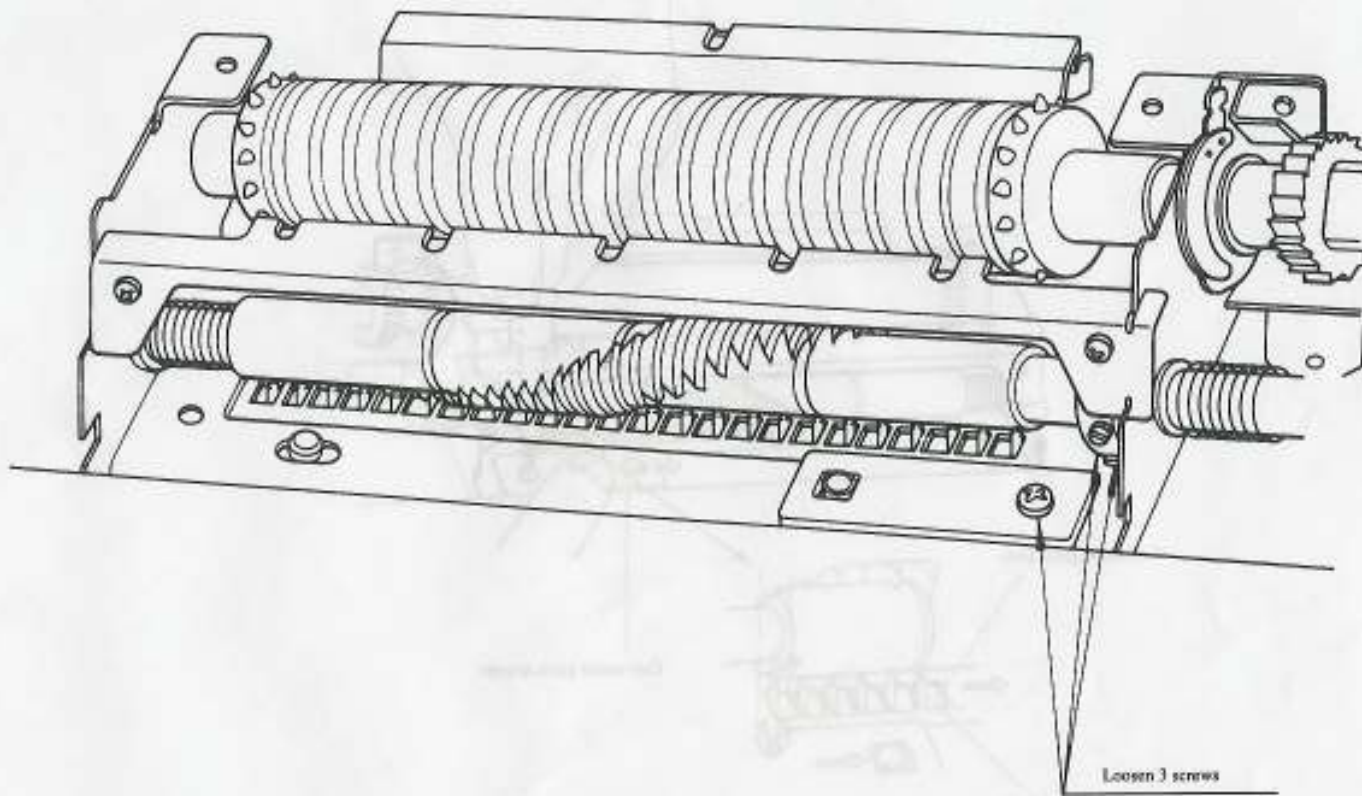

Fig. 29-7

How to adjust

- 3.3 Loosen two screws for rotary cam adjusting collar and one for card reader guide stopper.
NOTE: Do not take off screws.

Cause

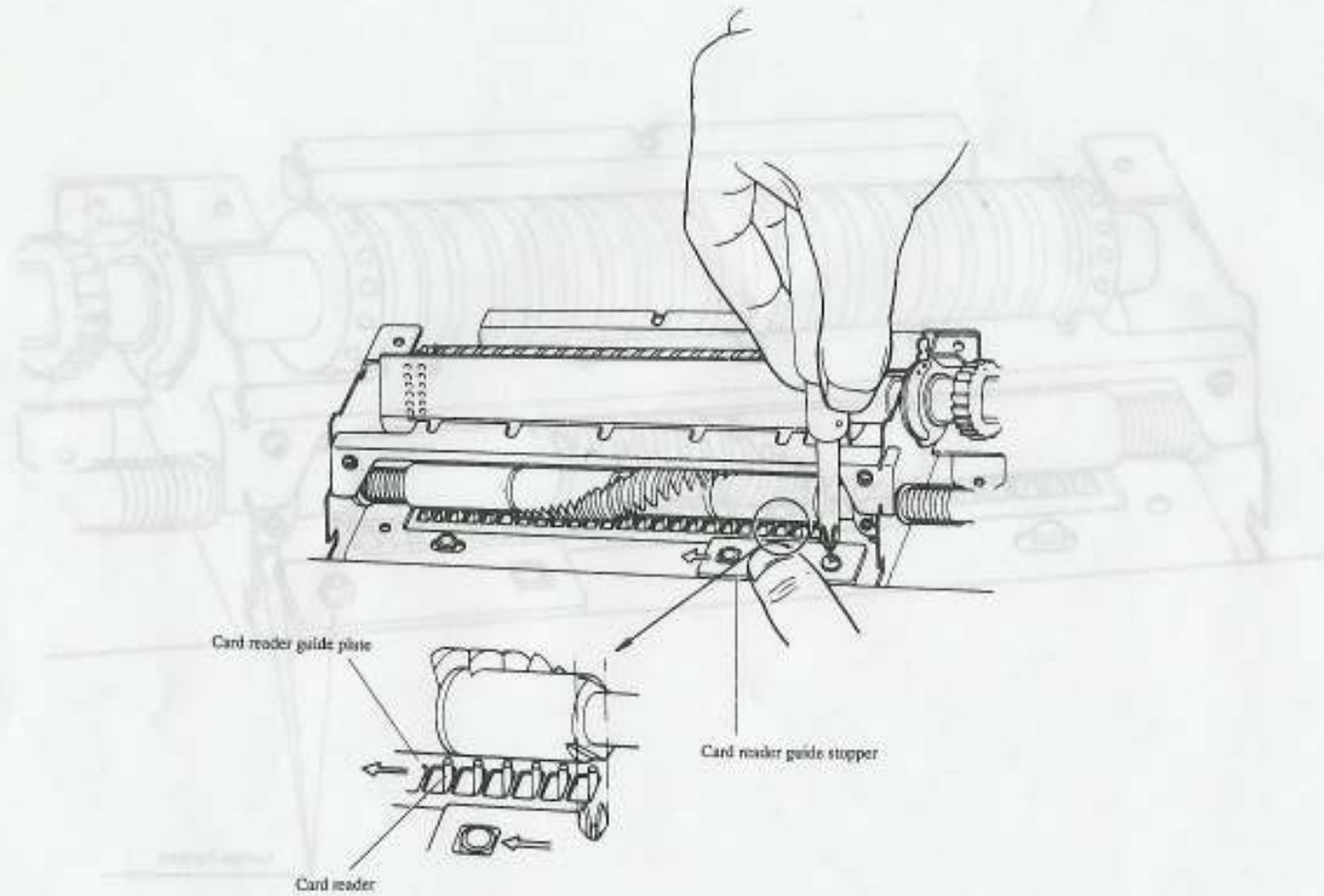

Fig. 26-8

How to adjust

- 3.4 By moving the card reader guide stopper, move the card reader guide plate to left hand side until the card readers softly touch the right side of the card reader guide window as shown in the figure. Then fasten the screw.

Cause

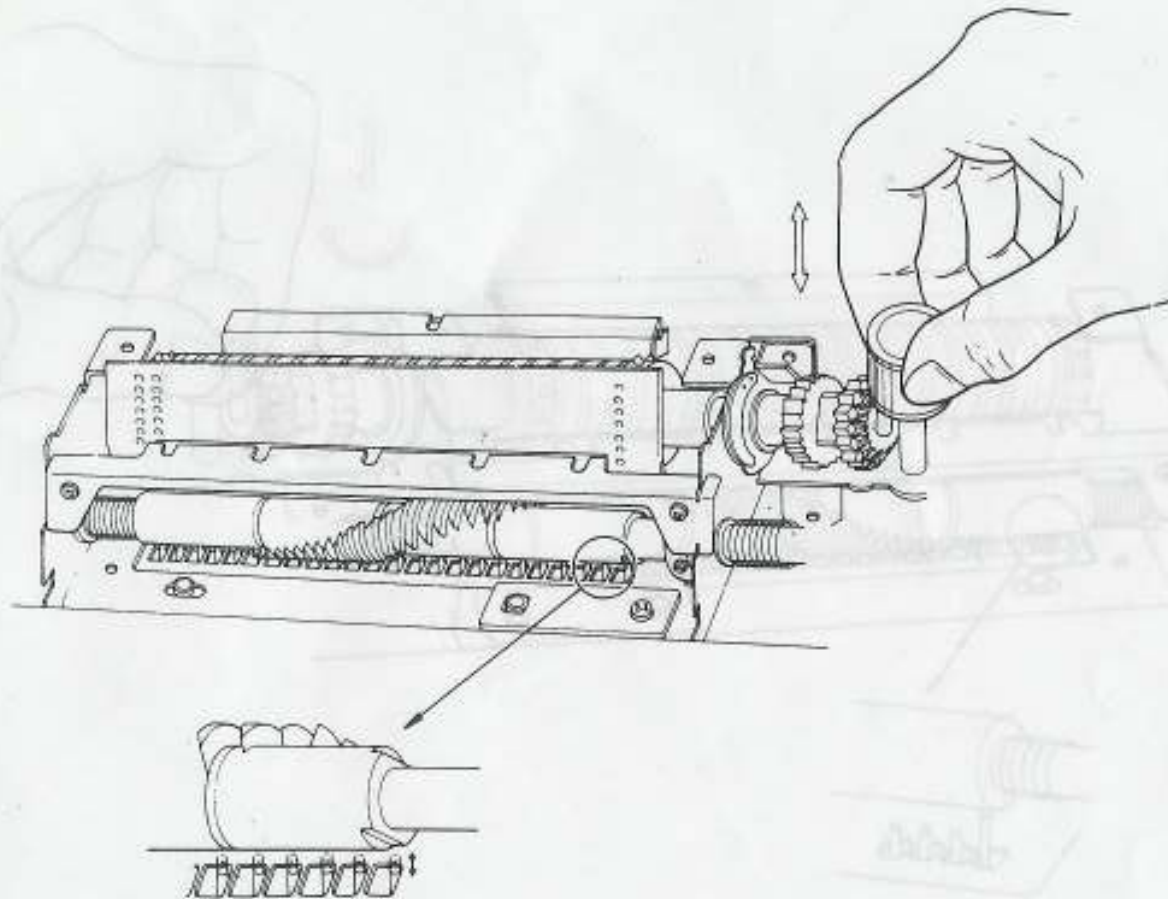

Fig. 20-9

How to adjust

- 3.5 Push down the card feeding knob to make the card readers down, then release it. The card readers must come up by spring pressure. If the card reader does not come up by spring pressure, repeat item 3.4.

Cause

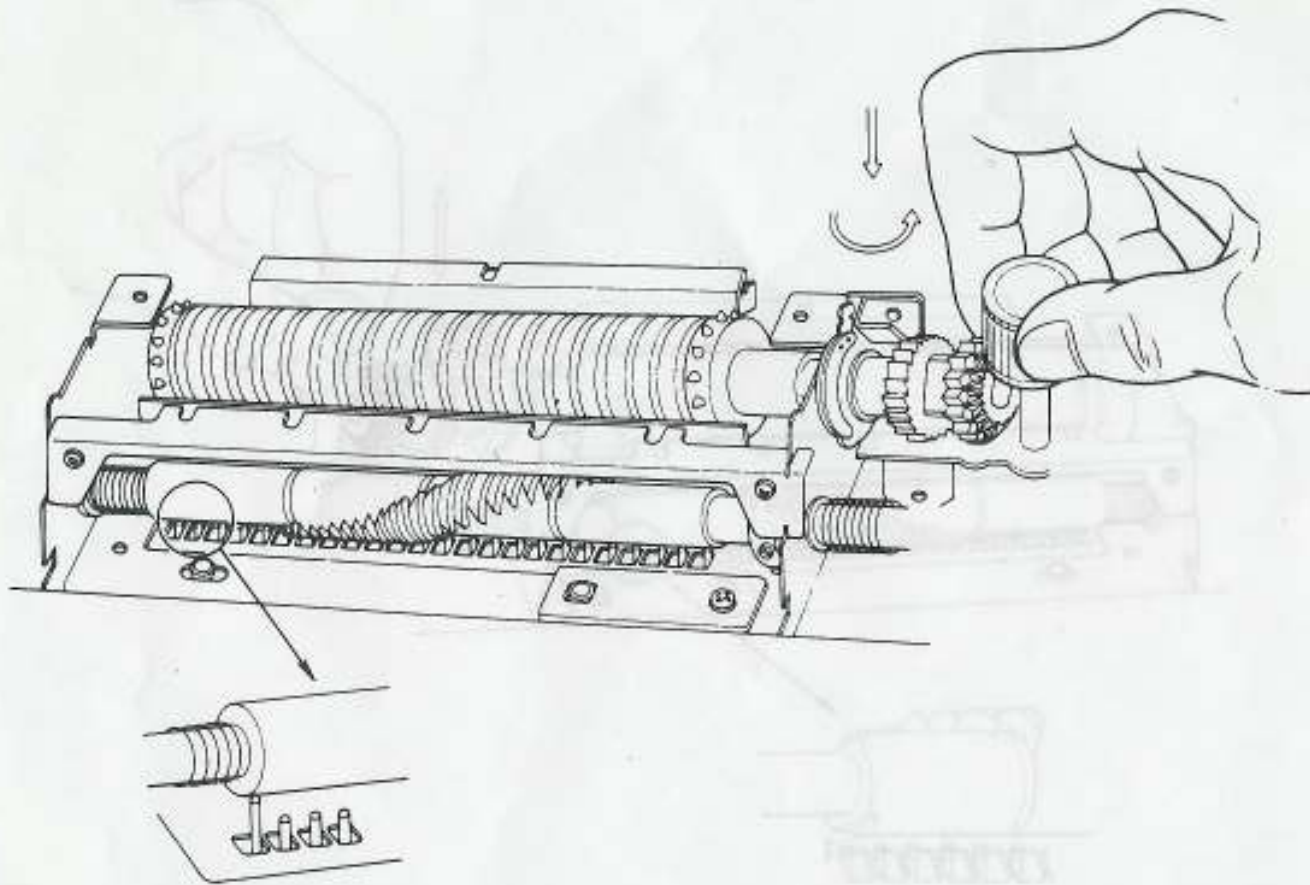

Fig. 20-10

How to adjust

3.6 Feed the punch card as shown in the figure. (One piece of card reader comes up.)

Cause

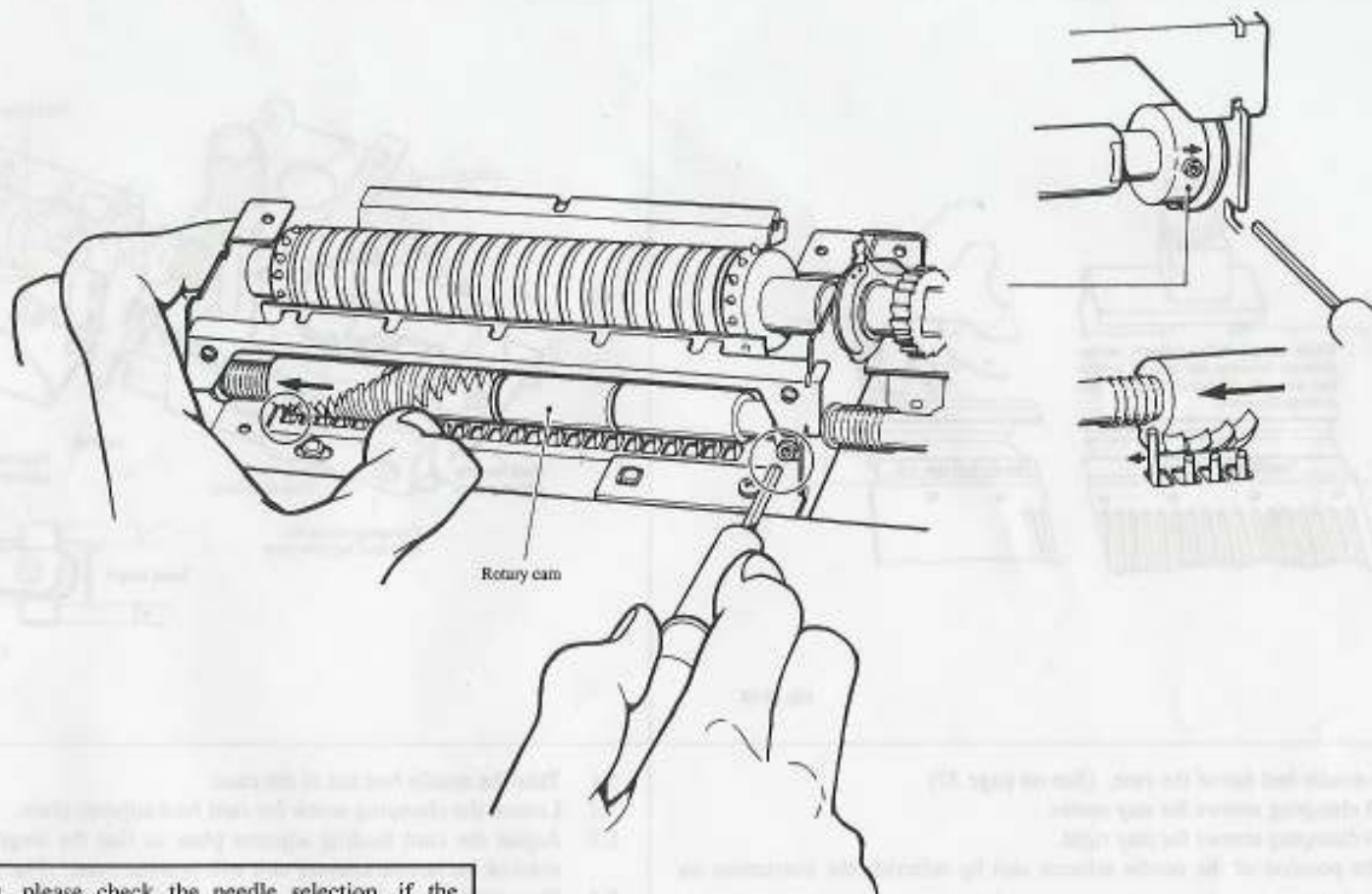

Fig. 20-11

After adjusting, please check the needle selection, if the problems still appear, please check the other part of the needle selection mechanism.

How to adjust

- 3.7 Turn the rotary cam so as to let the card reader in working position, and forcefully push the rotary cam to left until the card reader touch the left side of the card reader guide window, then tighten the two screws for the rotary cam adjusting collar securely by allen screwdriver. In this case, rotary cam adjusting collar must keep in touch with rotary cam holder plate.

(Cause 4)

Mounting of needle selector unit is not correct.

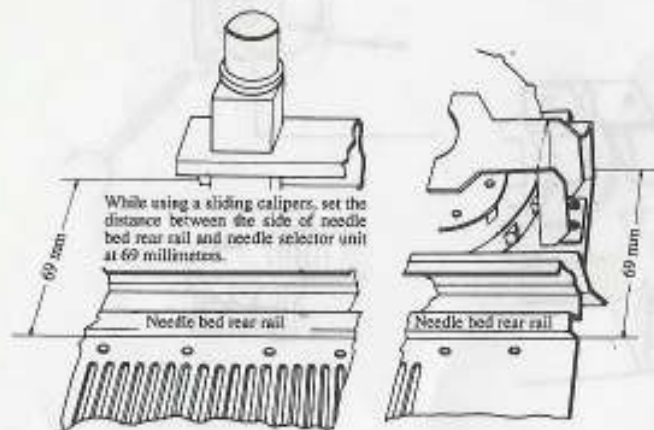

Fig. 20-12

(Cause 5)

Punch card is not fed correctly.

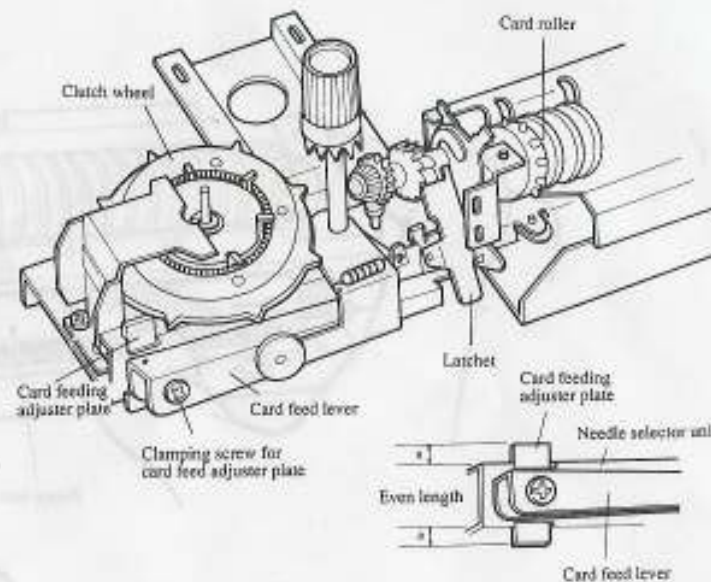

Fig. 20-13

Cause

How to adjust

- 4.1 Take the needle bed out of the case. (See on page 37)
- 4.2 Loosen 5 clamping screws for stay center.
- 4.3 Loosen 9 clamping screws for stay right.
- 4.4 Adjust the position of the needle selector unit by referring the instruction on page 46.
- 4.5 After adjusting, fasten the screws.

- 5.1 Take the needle bed out of the case.
- 5.2 Loosen the clamping screw for card feed adjuster plate.
- 5.3 Adjust the card feeding adjuster plate so that the length of upper and lower sides of the needle selector unit will become even. (Fig. 20-13)
- 5.4 Then tighten the clamping screw for card feed adjuster plate.

CONFIRMATION

Make sure:

- (1) That when the latchet is pushed up to the full, the card won't be fed at a pitch even if the latchet wheel is turned by hand.
- (2) That when the card is inserted and then the carriage (Change knob is set on KC.) is moved to right and left, the card is fed at a pitch accurately.

(Cause 6)

When the card lock lever is switched from the intermittent position to regular feeding position, the punch card is not fed because of the intermittent feed lever does not work smoothly.

(Cause 7)

The needle is bent.
(How to adjust)
Replace the needle.

Cause

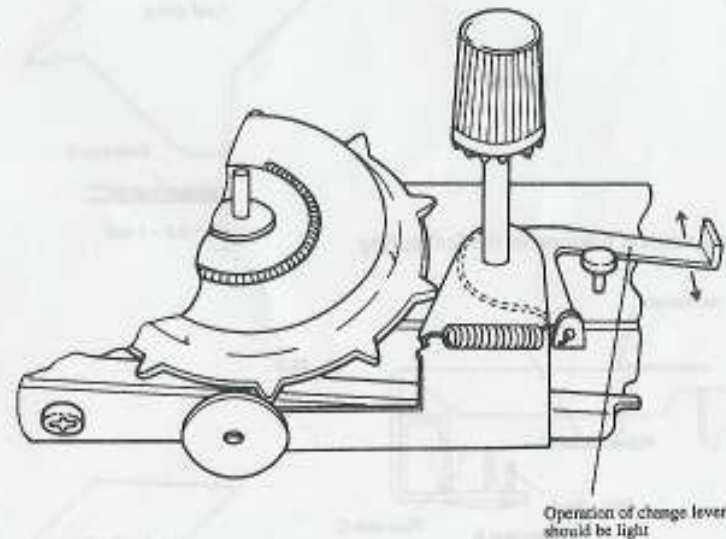
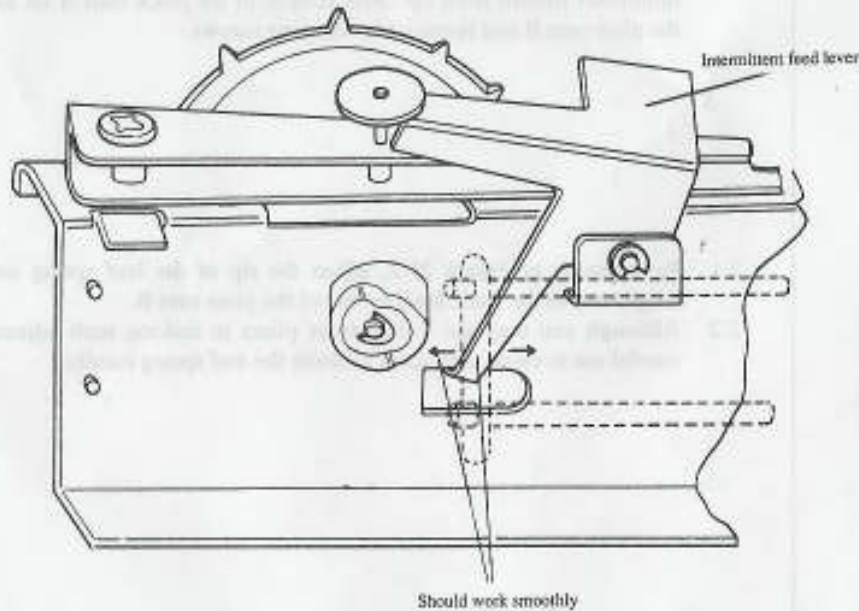

Fig. 20-14

How to adjust

Make the clearance between the intermittent feed lever and needle selector unit body so as to make the intermittent feed lever freely.

21. ADJUST L CARRIAGE

1. Stitch drops

HOW TO ADJUST L CARRIAGE

Cause

How to adjust

1. Wrong bilateral position of the leaf spring

Fig. 21-1

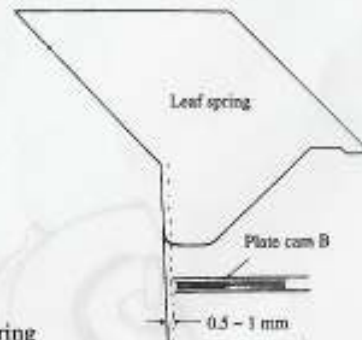

2. Wrong vertical position of the leaf spring

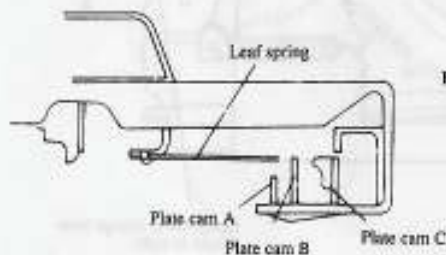

Fig. 21-2

3. Wrong position of the feed hook



Fig. 21-3

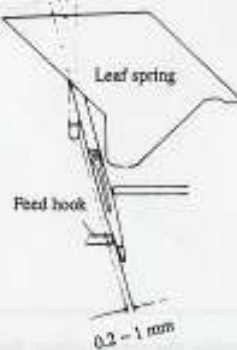

Fig. 21-4

- 1.1 Remove L Carriage cover and loosen right and left clamping nuts for the leaf spring.
- 1.2 By referring to Figure 21-1, place the leaf spring at a distance of 0.5~1 millimeter inward from the cross section of the plate cam B on the basis of the plate cam B and fasten with clamping screws.

- 2.1 By referring to Figure 21-2, adjust the tip of the leaf spring so as to be heightened to the same level as that of the plate cam B.
- 2.2 Although you may use a pincers or pliers in making such adjustments, be careful not to cause such tools to crook the leaf spring locally.

- 3.1 The feed hook is fixed with the feed hook clamping screw on the side of the sinker plate.
- 3.2 Loosen the feed hook clamping screw and move it inward and amounts of feeds will get smaller but move it outward and amounts of feeds will get larger.
- 3.3 By referring to Figure 21-4, adjust the feed hook so as to let a gap made in a moment the crossed two latch needles come off from the feed hook come below 0.2~1 millimeter.

Cause

4. When L carriage sinker plate is crooked.

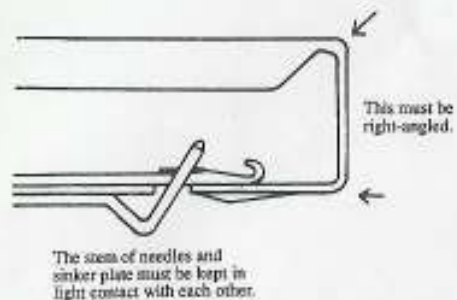
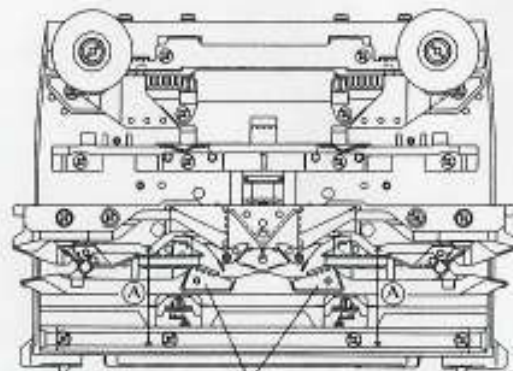

Fig. 21-5

5. When main cam is replaced.



End needle separation cam

* Dimension (A): 43 ± 0.1 mm

Fig. 21-6

How to adjust

- 4.1 Observe the sinker plate sideward and see if it is crooked.
 4.2 After confirming it by visual observation, put L Carriage into the needle bed and pull out latch needles to the position D, then inspect a gap between the sinker plate and the stem of latch needles. When latch needles are found raised by the sinker plate (or there is a wide gap), judge that the sinker plate is crooked and adjust the "crooked" section.

- 5.1 Remove right and left clamping screws for the L Carriage cover and take off the cover.
 5.2 Remove three clamping screws for main cam.
 5.3 From the back side of the L Carriage rear foot, measure by use of a sliding calipers to place main cam in such a way as shown in Figure 21-6 and fasten with three clamping screws.

***Other way to adjust the mounting dimension of the Main cam**

If you made the adjustment tool as shown in Fig. 21-7, you can adjust dimension A easily.

At first, place the adjustment tool between the Rear foot and the Main cam, then tighten the Main cam with two screws, while pushing it toward the "arrow" direction (Refer to Fig. 21-7).

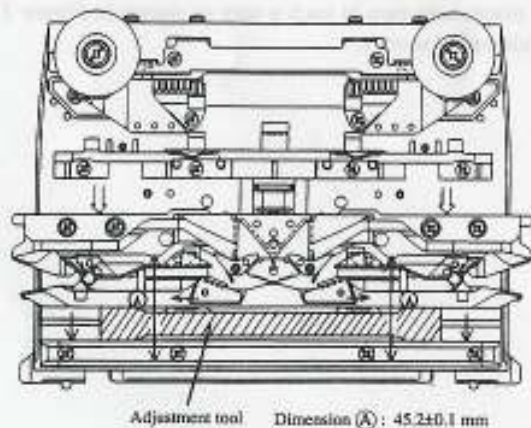
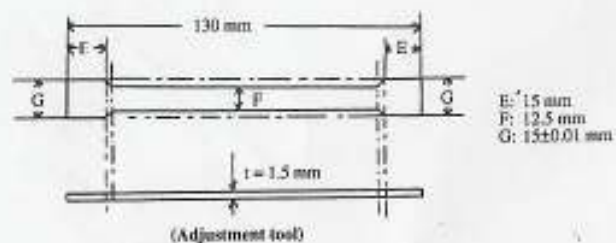

Fig. 21-7

22. RIBBING ATTACHMENT KR-830/KR-838

1. How to adjust the dimension in case of attaching KR-830/KR-838

*You can attach above mentioned ribbers to the knitters without any adjustment. However, if the dimension is wrong, please follow this manual.

*There are three adjusting positions, and once you do these adjustments, you are not required to adjust when you reattach the ribber.

1.1 Meeting of needles on both beds. (See Fig. 22-1)

The plain needles and purl needles are directly opposite to each other when the Racking indicator is on No. 5 while the Half pitch lever is on P. If not, adjust the position.

- (1) Set the Half pitch lever on P.
- (2) Set the Racking indicator on No. 5.
- (3) Loosen two screws (-) which are beside the mark D on the left end of the KR-needle bed.
- (4) By moving the KR-needle bed from side to side, adjust to get proper position (KH and KR-needles are met directly) as shown in Fig. 22-2.
- (5) After adjusting, fasten two screws tightly.

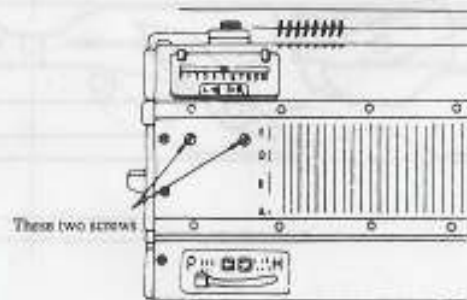

Fig. 22-1



* Needles of each beds are met directly.

Fig. 22-2

1.2 Height of ribber bed. (See Fig. 22-3)

Set the half pitch lever on H, and bring forward 10 each needles on both ends of KH-needle bed. Check the clearance between the back of the KH-needles and KR-gate pegs.

*STANDARD DIMENSION

FOR KR-830, 838 Height 1.1-1.7 mm

- (1) By pushing down the levers on both bracket, let down the ribber one step. At the back of the ribber, you will find out the nuts. Loosen these nuts with the spanner. Then return the ribber to the original position.
- (2) By moving both height adjusters up or down, obtain the proper height. (Refer to the above mentioned standard dimension.)
- (3) After adjusting, let down the ribber one step, and fasten lightly the nuts with the spanner. (Be careful not to fasten too much.) Then lift up the ribber to the normal position.

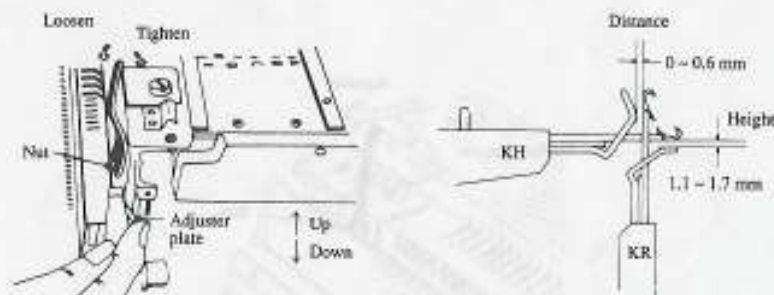

Fig. 22-3

1.3 Distance between two beds. (See Fig. 22-3 and Fig. 22-4.)

Loosen the clamps for reinforcing arm. Bring forward 10 each needles on both ends of KR-needle bed. Check the distance between the back of the KR-needles and KH-gate pegs.

***STANDARD DIMENSION.**

(THE COMMON DIMENSION FOR THE THREE MODELS.)

0-0.6 mm

- (1) Loosen both thumb screws with the spanner.
- (2) To obtain the proper distance (0-0.6 mm), adjust by turning the bolts on both sides of bracket with the spanner.
Turning to the left Close
Turning to the right Separate
- (3) After adjusting, go back the needles to A position and fasten both thumb screws.
- (4) Fasten the clamps for reinforcing arm.

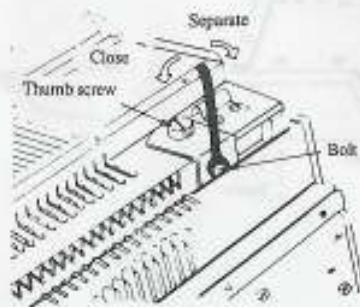

Fig. 22-4

MOUNTING DIMENSIONS OF EACH PART OF KR-830/KR-838/KR-850.

* KR-carriage (See Fig. 22-5)

Mounting dimension of sub raising cam 14.5 mm
(Dimension between the sub raising cam and the rear foot of KR-carriage.)

Mounting dimension of sub stitch cam 51.3 mm
(Dimension between the sub stitch cam and the rear foot of KR-carriage.)

(Please check when the KR-carriage does not slide on the needle bed smoothly.)

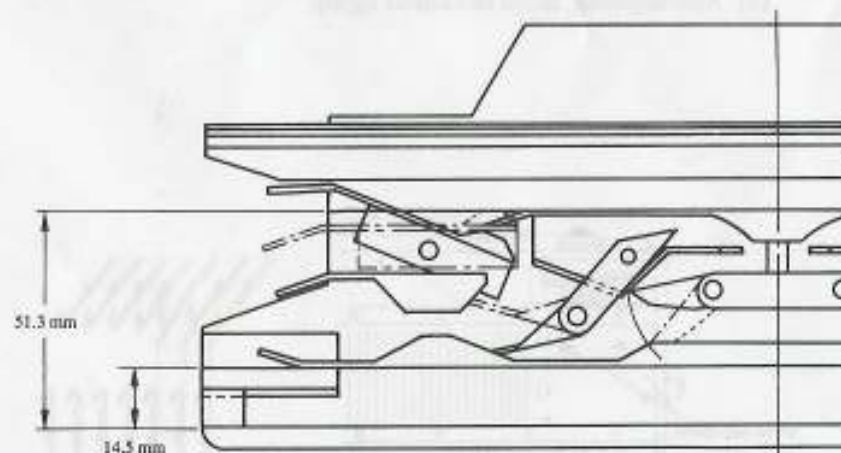

Fig. 22-5

23. RIBBING ATTACHMENT KR-850

I. How to adjust the dimension in case of attaching KR-850

* You can attach KR-850 to above mentioned knitters without any adjustment, however if the dimension is wrong, please follow this manual.

1.1 Standard dimension (See Fig. 23-1)

* **DISTANCE** The clearance between the back of the KR-needles and KH-gate pegs is 0-0.6 mm.

* **HEIGHT** The clearance between the back of the KH-needles and KR-gate pegs is 0.7-1.3 mm.

1.2 For wider distance than the standard

- (1) Loosen a little the table clamps and the thumb screws of setting plates R and L.
- (2) Pull the ribber toward you.
- (3) Insert the slotted screwdriver into the slot of setting plates and pry upward to widen the slot for the adjustment like the Fig. 23-2 and Fig. 23-4.
- (4) After the adjustment, push the ribber to the knitter to attach correctly and fasten the thumb screws of setting plates, and table clamps.
- (5) Check the distance referring Fig. 23-1.

1.3 For narrower distance than the standard

- (1) Loosen a little the table clamps and the thumb screws of setting plates R and L.
- (2) Adjust the clearance by means of prying upward to narrow the slots of setting plates with a slotted screwdriver while being the stay for the needle bed as the fulcrum. (See Fig. 23-3 and Fig. 23-4)
- (3) After the adjustment, fasten the thumb screws of setting plates and table clamps.
- (4) Check the distance referring Fig. 23-1.

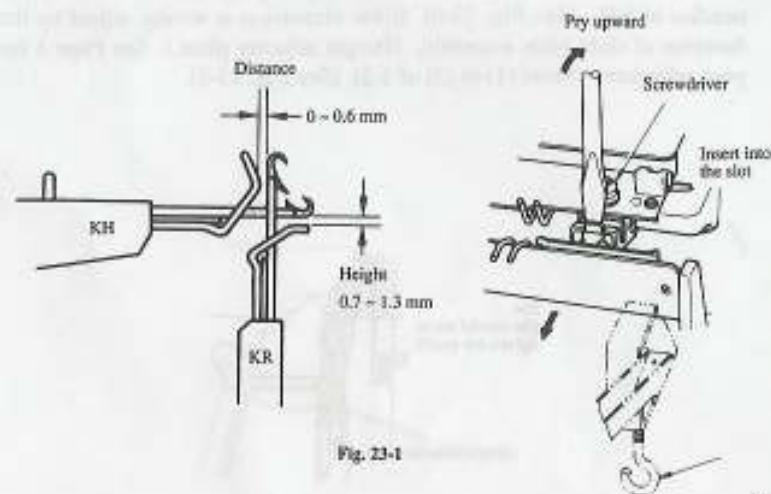

Fig. 23-1

Fig. 23-2

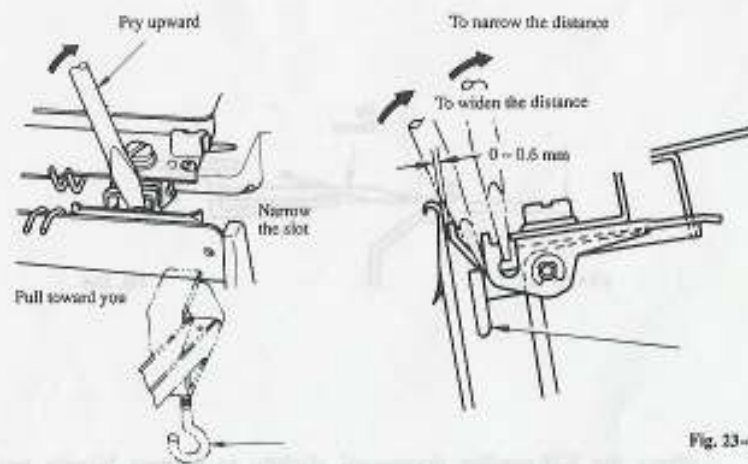

Fig. 23-3

Fig. 23-4

1.4 Height-adjustment

Please check the clearance between KR-gate pegs and the back of the needles of KH. (See Fig. 23-6) If the dimension is wrong, adjust by the function of slide plate assembly. (Height adjuster plate.) See Page 1 for your reference. (From (1) to (3) of 1.2) (See Fig. 23-5)

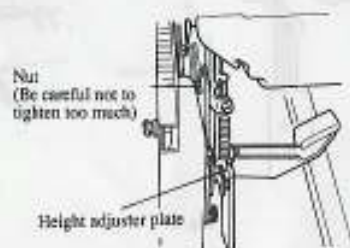

Fig. 23-5



Fig. 23-6

(Press the KH-needles downward slightly to contact Needle position indicator)

2. The dimension between guide plate or yarn feeder, (latch presser) and rear rail of KH.

(Mounting dimension of connecting arm)

Generally, it is not needed to adjust above mentioned dimension.

However, if the contact or interference between latch presser and purl needles or plain needles is caused by some accidents, please adjust the dimension following this chart.

Model	Dimensions			Figure
	A	B	*C	
KR-830	24.5 ± 0.5 mm	18 mm	123.6 mm	
KR-838 KR-850	23.5 ± 0.3 mm	16 mm	123.0 mm	

*NOTE: C is the dimension between the yarn feeder or guide plate (latch presser) and rear rail of KH.

3. Mounting dimensions of each part of ribbers

* Mounting dimensions of gate pegs of ribbers

Model	The dimension between the gate pegs and the rear rail of the KR-needle bed
KR-838, 850	102.4 mm

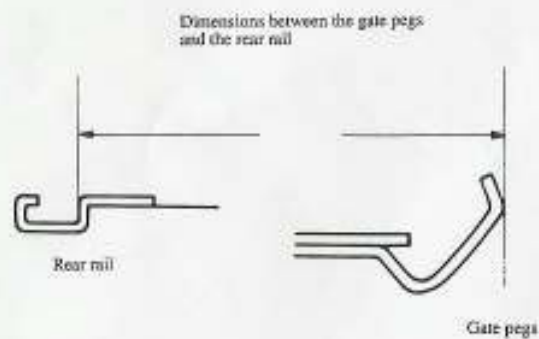

Fig. 23-7

24. KNIT LEADER

KNIT-LEADER KL-116

1. Inclining the sheet

The sheet feeding gear shaft is inclined.

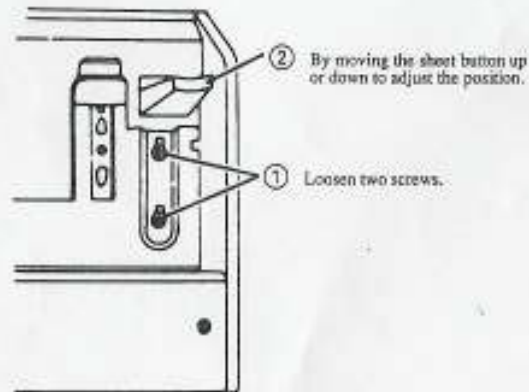

Fig. 24-1

Cause

How to adjust

- 1.1 Loosen two clamping screws.
- 1.2 By moving the sheet button up or down, adjust the incline of the sheet feeding gear shaft. Then, fasten the screws.
(Insert the sheet into the Knit-leader, and check.)