

PIXMA iP4000

SERVICE MANUAL

Canon

Scope

This manual has been issued by Canon Inc., to provide the service technicians of this product with the information necessary for qualified persons to learn technical theory, installation, maintenance, and repair of products. The manual covers information applicable in all regions where the product is sold. For this reason, it may contain information that is not applicable to your region.

Revision

This manual could include technical inaccuracies or typographical errors due to improvements or changes made to the product. When changes are made to the contents of the manual, Canon will release technical information when necessary. When substantial changes are made to the contents of the manual, Canon will issue a revised edition.

The following do not apply if they do not conform to the laws and regulations of the region where the manual or product is used:

Trademarks

Product and brand names appearing in this manual are registered trademarks or trademarks of the respective holders.

Copyright

All rights reserved. No parts of this manual may be reproduced in any form or by any means or translated into another language without the written permission of Canon Inc., except in the case of internal business use.

Copyright © 2004 by Canon Inc.
CANON INC.
Inkjet SFP Quality Assurance Div.
16-1, Shimonoge 3-chome, Takatsu-ku, Kawasaki, Kanagawa 213-8512, Japan



I. MANUAL OUTLINE

This manual consists of the following three parts to provide information necessary to service the PIXMA iP4000:

Part 1: Maintenance

Information on maintenance and troubleshooting of the PIXMA iP4000

Part 2: Technical Reference

New technology and technical information such as FAQ's (Frequently Asked Questions) of the PIXMA iP4000

Part 3: Appendix

Block diagrams and pin layouts of the PIXMA iP4000

Reference:

This manual does not provide sufficient information for disassembly and reassembly procedures. Refer to the graphics in the separate Parts Catalog.



II. TABLE OF CONTENTS

Part 1: MAINTENANCE

1. MAINTENANCE

1-1. Adjustment, Periodic Maintenance, Periodic Replacement Parts, and Replacement Consumables by Service Engineer

1-2. Customer Maintenance

1-3. Product Life

1-4. Special Tools

1-5. Serial Number Location

2. LIST OF ERROR DISPLAY / INDICATION

2-1. Operator Call Errors

2-2. Service Call Errors

2-3. Warnings

2-4. Troubleshooting by Symptom

3. REPAIR

3-1. Notes on Service Part Replacement (and Disassembling / Reassembling)

3-2. Special Notes on Repair Servicing

3-3. Adjustment / Settings

(1) Paper feed motor adjustment

(2) Gear phase adjustment

(3) Grease application

(4) Waste ink counter setting

(5) User mode

(6) Service mode

Service test print, EEPROM initialization, Waste ink counter reset

Destination settings

3-4. Verification Items

(1) Service test print

(2) EEPROM information print

4. PRINTER TRANSPORTATION

Part 2: TECHNICAL REFERENCE

1. NEW TECHNOLOGIES

2. CLEANING MODE AND AMOUNT OF INK PURGED

3. FAQ (Problems Specific to the iP4000 and Corrective Actions)

Part 3: APPENDIX

1. BLOCK DIAGRAM

2. CONNECTOR LOCATION AND PIN LAYOUT

2-1. Logic Board Ass'y

2-2. Carriage Board (Print Head Connector)

Part 1

MAINTENANCE



1. MAINTENANCE

1-1. Adjustment, Periodic Maintenance, Periodic Replacement Parts, and Replacement Consumables by Service Engineer

(1) Adjustment

Adjustment	Timing	Purpose	Tool	Approx. time
EEPROM initialization (EEPROM settings)	At logic board ass'y replacement	To initialize settings other than the following: - USB serial number - Destination setting - Waste ink counter - CD-R correction value	None.	1 min.
Destination settings (EEPROM settings)	At logic board ass'y replacement	To set the destination.	None.	1 min.
Waste ink counter resetting (EEPROM settings)	- At bottom case unit replacement - At ink absorber (QC1-4221 / 4222 / 4223 / 4224 / 4263 / 4264 / 4864 / 4257) replacement	To reset the waste ink counter.	None.	1 min.
CD-R sensor / automatic print head alignment sensor correction (EEPROM settings)	- At logic board ass'y replacement - At carriage unit replacement	To correct the CD-R and automatic print head alignment sensor.	None. (Correction performed through service test print)	2 min.
Print head alignment	- At print head replacement - At logic board ass'y replacement - At carriage unit replacement	To ensure accurate dot placement.	- None. (printer buttons) - Computer (settings via the printer driver)	2 min.
Paper feed motor position adjustment*1	At paper feed motor unit replacement	To adjust the belt tension. (Position the paper feed motor so that the belt is stretched tight.)	None.	2 min.
Grease application	- At carriage unit replacement - At chassis' upper gear replacement - At shaft lift (QC1-4331) replacement	- To maintain sliding properties of the carriage, carriage shaft, and shaft lift. - To protect the chassis' upper gear.	- FLOIL KG-107A (QY9-0057) - MOLYKOTE HP300 (QY9-0035)	1 min.

Note: DO NOT loosen the red screws on both sides of the main chassis, securing the carriage shaft positioning.

*1: Red screws of paper feed motor

The red screws securing the paper feed motor may be loosened only at replacement of the paper feed motor unit.

(2) Periodic maintenance

No periodic maintenance is necessary.

(3) Periodic replacement parts

There are no parts in this printer that require periodic replacement by a service engineer.

(4) Replacement consumables

There are no consumables that require replacement by a service engineer.

1-2. Customer Maintenance

Adjustment	Timing	Purpose	Tool	Approx. time
Print head alignment	At print head replacement.	To ensure accurate dot placement.	- Printer buttons - Computer (automatic settings via the printer driver)	3 min.
Print head cleaning	When print quality is not satisfying.	To improve nozzle conditions.	- Printer buttons - Computer (settings via the printer driver)	1 min.
Print head deep cleaning	When print quality is not satisfying, and not improved by print head cleaning.	To improve nozzle conditions.	Computer (settings via the printer driver)	2 min.
Ink tank replacement	When an ink tank becomes empty. (No ink error)	-----	-----	2 min.
Paper feed roller cleaning	When paper does not feed properly.	To clean the paper feed rollers.	Printer buttons	2 min.
CD-R print position adjustment	At CD-R printing, when necessary	To correct CD-R print position.	Computer (application software)	5 min.
Bottom plate cleaning	When the back side of the paper is smeared	To clean the platen ribs.	Computer (application software)	1 min.

1-3. Product Life

(1) Printer

Specified print volume (I) or the years of use (II), whichever comes first.

(I) Print volume

		PIXMA iP4000
		18,000 pages
Black	1,500 character pattern	7,200 pages
Color	A4, 7.5% duty per color pattern	5,400 pages
	A4, photo, borderless printing	300 pages
	4 x 6, photo, borderless printing	3,600 pages
	Postcard, photo, borderless printing	1,500 pages

(II) Years of use

PIXMA iP4000: 5 years of use

(2) Print head

Print volume:

		PIXMA iP4000
		18,000 pages
Black	1,500 character pattern	7,200 pages
Color	A4, 7.5% duty per color pattern	5,400 pages
	A4, photo, borderless printing	300 pages
	4 x 6, photo, borderless printing	3,600 pages
	Postcard, photo, borderless printing	1,500 pages

(3) Ink tank (target value)

PIXMA iP4000:

- BCI-3eBK: 740 pages (1,500 character pattern, plain paper / standard mode)
1,500 pages (ISO JIS-SCID No. 5 / plain paper / standard mode)
- BCI-6C: 550 pages (ISO JIS-SCID No. 5 / plain paper / standard mode)
- BCI-6M: 430 pages (ISO JIS-SCID No. 5 / plain paper / standard mode)
- BCI-6Y: 360 pages (ISO JIS-SCID No. 5 / plain paper / standard mode)
- BCI-6BK: 2,000 pages (ISO JIS-SCID No. 5 / plain paper / standard mode)

1-4. Special Tools

Name	Tool No.	Application	Remarks
MOLYKOTE HP300	QY9-0035-000	To be applied to the chassis' upper gear, and to the sliding portion of the shaft lift.	In common with other models.
FLOIL KG-107A	QY9-0057-000	To be applied to the sliding portion of the carriage, and the carriage shaft.	In common with other models.

1-5. Serial Number Location

On the carriage flexible cable holder (visible when the access cover is open).



[To the top](#)

← <Part 1: 1. MAINTENANCE> →

2. LIST OF ERROR DISPLAY / INDICATION

Errors are indicated by the LED, and warnings are displayed on the monitor of the computer connected to the printer.

2-1. Operator Call Errors (by LED Blinking in Orange)

LED blinking in orange	Error [Error code]	Solution	Remarks
2 times	No paper. (ASF) [1000]	Set the paper in the ASF, and press the Resume/Cancel button.	
	No CD-R tray. [1001]*1	Set the CD-R tray, and press the Resume/Cancel button.	
	No paper in the cassette. [1003] (No paper in the front paper feed cassette.)	Set the paper in the cassette, and press the Resume/Cancel button.	
3 times	Paper jam. [1300]	Remove the jammed paper, and press the Resume/Cancel button.	
	Paper jam in the under guide. [1304]		
	Paper jam in the rear guide. [1303]		
	Front door closed. [1250]	Open the paper output tray.	
4 times	No ink. [1601 / 1602 / 1611 / 1612 / 1613]	Replace the empty ink tank(s), or press the Resume/Cancel button.	Pressing the Resume/Cancel button will exit the error without ink tank replacement, however, ink may run out during printing.
5 times	The print head is not installed [1401], or it is not properly installed (EEPROM data of the print head is faulty) [1403 / 1405].	Install the print head properly, and close the access cover. Or, with the print head installed, turn the printer off and on.	
6 times	Inner cover open. [1841]*2	Close the inner cover, and press the Resume/Cancel button.	
	Inner cover open (during printing on paper). [1846]*2	Close the inner cover, and press the Resume/Cancel button.	
	CD-R tray guide closed (during CD-R printing). [1850 / 1855]*1	Open the CD-R tray guide, set the CD-R tray properly, and press the Resume/Cancel button.	
	CD-R tray guide open (during printing to paper). [1851 / 1856]*1	Close the CD-R tray guide, and press the Resume/Cancel button.	
7 times*1	No CD-R or DVD-R. [1002]	After setting a CD-R or DVD-R in the tray, set the tray in the tray guide, and press the Resume/Cancel button.	
8 times	Warning: The waste ink absorber becomes almost full (approx. 95% of the maximum capacity). [1700]	Pressing the Resume/Cancel button will exit the error, and enable printing. In repair servicing, replace the bottom case unit (QM2-1205), or the ink absorbers (QC1-4222 / 4223 / 4224 / 4263 / 4264 / 4864 / 4221 / 4257).	The service call error, indicating the waste ink absorber is full, is likely to occur soon.
9 times	The connected digital camera or digital video camera does not support Camera Direct Printing. [2001]	After removing the cable between the camera and the printer, press the Resume/Cancel button, and re-connect the cable.	
10 times	Automatic duplex printing cannot be performed (paper size not supported). [1310]	Press the Resume/Cancel button to eject the paper being used at error occurrence. Printing will resume from on the front side of the next page.	Data which was to be printed on the back side of paper at error occurrence is skipped (not printed).
11 times	Failed in automatic print head alignment. [2500]	Press the Resume/Cancel button, and after confirming the following, perform print head alignment again: - Set an appropriate type and size of paper (plain paper, A4 or letter). - Check that the nozzle check pattern is properly printed (all ink ejected, no faint printing). - Protect the paper output slot from exposure to excessive light.	
	Access cover open. [1200]	Close the access cover.	

*1: Only for models supporting CD-R printing

*2: Only for models not supporting CD-R printing

2-2. Service Call Errors (by LED Blinking in Orange and Green Alternately, or Lit in Orange)

LED alternate blinking in orange and green	Error [Error code]	Solution (Replacement of listed parts, which are likely to be faulty)
2 times	Carriage error [5100]	- Carriage unit (QM2-1209) - Timing slit strip film (QC1-4284) - Logic board ass'y (QM2-1548)*1 - Carriage motor (QK1-0545)
3 times	Paper feed error [6000]	- Timing sensor unit (QM2-1213) - Timing slit disk film (QC1-4833) - Feed roller ass'y (QL2-0598) - Platen unit (QM2-1215) - Logic board ass'y (QM2-1548)*1 - PAPER FEED MOTOR (QK1-0550)
4 times	Purge unit error [5C00]	- Purge unit (QM2-1210) - Logic board ass'y (QM2-1548)*1
5 times	ASF (cam) sensor error [5700]	- Sheet feed unit (QM2-1220)
6 times	Internal temperature error [5400]	- Logic board ass'y (QM2-1548)*1
7 times	Waste ink absorber full [5B00]	- Ink absorber (QC1-4222 / 4223 / 4224 / 4263 / 4264 / 4864 / 4221 / 4257) - Bottom case unit (QM2-1205)*2
8 times	Print head temperature rise error [5200]	- Print head (QY6-0049) - Logic board ass'y (QM2-1548)*1
9 times	EEPROM error [6800]	- Logic board ass'y (QM2-1548)*1
11 times	Carriage lift mechanism error [5110]	- Lift shaft(QC1-4331) - Photo interrupter (WG8-5624) - Sheet feed unit (QM2-1220) - Logic board ass'y (QM2-1548)*1
12 times	AP position error [6A00]	- Sheet feed unit (QM2-1220) - Logic board ass'y (QM2-1548)*1
13 times	Paper feed position error [6B00]	- Sheet feed unit (QM2-1220) - Logic board ass'y (QM2-1548)*1
14 times	Paper feed cam sensor error [6B10]	- Sheet feed unit (QM2-1220) - Logic board ass'y (QM2-1548)*1
15 times	USB Host VBUS overcurrent [9000]	- Logic board ass'y (QM2-1548)*1
16 times	Valve sensor error [6C00]	- Logic board ass'y (QM2-1548)*1
17 times	Motor driver error [6D00]	- Logic board ass'y (QM2-1548)*1
20 times	Other hardware error [6500]	- Logic board ass'y (QM2-1548)*1
Continuous alternate blinking	ROM error	- Logic board ass'y (QM2-1548)*1
Lights in orange	RAM error	- Logic board ass'y (QM2-1548)*1

*1: Before replacement of the logic board ass'y, check the waste ink amount (by service test print or EEPROM information print). If the waste ink amount is 7% or more, also replace the bottom case unit (QM2-1205) or the ink absorbers (QC1-4222 / 4223 / 4224 / 4263 / 4264 / 4864 / 4221 / 4257) when replacing the logic board ass'y.

[\[See Section 3-3. Adjustment / Settings, \(6\) Service mode, for details.\]](#)

*2: Reset the waste ink counter when replacing the bottom case unit.

[\[See Section 3-3. Adjustment / Settings, \(6\) Service mode, for details.\]](#)

2-3. Warnings

Printer (no LED indications):

Displayed warning	Remarks
Low ink of 3eBK, 6C, 6M, 6Y, or 6BK (at detection of no remaining raw ink)	Status indication only.
Print head temperature rise	If the print head temperature is high when the access cover is opened, the warning is displayed*1. When the print head temperature falls, the warning is released.
Protection of excess rise of the print head temperature	If the print head temperature exceeds the specified limit, a Wait is inserted during printing,

*1: If the warning is displayed, the carriage does not move to the ink tank replacement position when the access cover is opened.

2-4. Troubleshooting by Symptom

	Symptom	Solution	Remarks
Faulty operation	The power does not turn on. The power turns off immediately after power-on.	Replace the - AC adapter, or - logic board ass'y*1.	
	The print head is not recognized. The print head does not move to the home position.	Remove and re-install the print head, or replace the - print head, or - logic board ass'y*1.	
	A strange noise occurs.	Remove foreign material, or attach a removed part if any.	
	Printing stops mid-way.	Replace the logic board ass'y*1.	
Paper feed problems	Multiple sheets feed.	Replace the - sheet feed unit, - cassette.	
	Paper does not feed.	Remove foreign material, or replace the - sheet feed unit, or - cassette.	
	Paper feeds at an angle.	Remove foreign material, or replace the - sheet feed unit, or - cassette.	
Unsatisfactory print quality	No printing, or no color ejected.	Replace the - ink tank, - print head*2, - logic board ass'y*1, or - purge unit.	
	Printing is faint, or white lines appear on printouts even after print head cleaning. Line(s) not included in the print data appears on printouts.	Remove and re-install the print head, or replace the - ink tank, - print head*2, - purge unit, or - logic board ass'y*1.	
	Paper gets smeared.	Feed several sheets of paper, perform bottom plate cleaning, or clean the paper path with cotton swab or cloth.	
	A part of a line is missing on printouts.	Replace the - ink tank, or - print head*2.	
	Color hue is incorrect.	Replace the - ink tank, or - print head*2, or perform print head alignment.	

Printing is incorrect.	Replace the logic board ass'y*1.
No ejection of black ink.	Replace the - ink tank, or - print head*2.
Graphic or text is enlarged on printouts.	When enlarged in the carriage movement direction, clean grease or oil off the timing slit strip film, or replace the - timing slit strip film, - carriage unit, or - logic board ass'y*1. When enlarged in the paper feed direction, clean grease or oil off the timing slit disk film, or replace the - timing slit disk film, - timing sensor unit, or - logic board ass'y*1.

*1: Before replacement of the logic board ass'y, check the waste ink amount (by service test print or EEPROM information print). If the waste ink amount is 7% or more, also replace the bottom case unit (QM2-1205) or the ink absorbers (QC1-4222 / 4223 / 4224 / 4263 / 4264 / 4864 / 4221 / 4257) when replacing the logic board ass'y.
[See Section 3-3. Adjustment / Settings, (6) Service mode, for details.]

*2: Replace the print head only after the print head deep cleaning is performed 2 times, and when the problem persists.

[To the top](#)

 <Part 1: 2. LIST OF ERROR DISPLAY / INDICATION> 

3. REPAIR

3-1. Notes on Service Part Replacement (and Disassembling / Reassembling)

Service part	Notes on replacement*1	Adjustment / settings	Operation check
Logic board ass'y QM2-1548	<ul style="list-style-type: none"> - Before removal of the logic board ass'y, remove the power cord, and allow for approx. 1 minute (for discharge of capacitor's accumulated charges), to prevent damages to the logic board ass'y. - Before replacement, check the waste ink amount (by service test print or EEPROM information print). If the waste ink amount is 7% or more, also replace the bottom case unit or the ink absorbers when replacing the logic board ass'y. See 3.3. Adjustment / Settings, (6) Service mode, for details. <p>[See 3-3. Adjustment / Settings, (6) Service mode, for details.]</p>	<p>After replacement:</p> <ol style="list-style-type: none"> 1. Initialize the EEPROM. 2. Reset the waste ink counter. 3. Set the destination in the EEPROM. 4. Correct the CD-R and automatic print head alignment sensors. <p>[See 3-3. Adjustment / Settings, (6) Service mode, for details of 1 to 4]</p> <ol style="list-style-type: none"> 5. Perform the print head alignment in the user mode. 	<ul style="list-style-type: none"> - EEPROM information print - Service test print - Printing via parallel or USB connection - Direct printing from a digital camera
Bottom case unit QM2-1205		<p>After replacement:</p> <ol style="list-style-type: none"> 1. Reset the waste ink counter. <p>[See 3.3. Adjustment / Settings, (6) Service mode.]</p>	- Service test print
Ink absorber QC1-4222 / 4223 / 4224 / 4263 / 4264 / 4864 / 4221 / 4257			
Carriage unit QM2-1209		<p>At replacement:</p> <ol style="list-style-type: none"> 1. Apply grease to the sliding portions. <p>[See 3-3. Adjustment / Settings, (3) Grease application.]</p> <p>After replacement:</p> <ol style="list-style-type: none"> 1. Correct the CD-R and automatic print head alignment sensors. <p>[See 3.3. Adjustment / Settings, (6) Service mode.]</p> <ol style="list-style-type: none"> 2. Perform the print head alignment in the user mode. 	- Service test print (Confirm CD-R and automatic print head alignment sensor correction.)
Paper feed motor unit QK1-0550	- The red screws securing the paper feed motor are allowed to be loosened. (DO NOT loosen any other red screws.)	<p>At replacement:</p> <ol style="list-style-type: none"> 1. Adjust the paper feed motor. <p>[See 3-3. Adjustment / Settings, (1) Paper feed motor adjustment.]</p>	

Service part	Notes on replacement*1	Adjustment / settings	Operation check
Shaft lift QC1-4331		At replacement: 1. Apply grease to the sliding portions. [See 3.3. Adjustment / Settings, (3) Grease application.]	- Service test print
Timing slit strip film QC1-4284	<ul style="list-style-type: none"> - Upon contact with the film, wipe the film with ethanol. - Confirm no grease is on the film. (Wipe off any grease thoroughly with ethanol.) - Do not bend the film 	After replacement: 1. Perform the print head alignment in the user mode.	- Service test print
Timing slit disk film QC1-4833			
Print head QY6-0049		After replacement: 1. Perform the print head alignment in the user mode.	- Service test print

*1: General notes:

- Make sure that the flexible cables and wires in the harness are in the proper position and connected correctly.
[\[See 3-2. Special Notes on Repair Servicing, \(1\) Flexible cable and harness wiring, connection, for details.\]](#)
- Do not drop the ferrite core, which may cause damage.
- Protect electrical parts from damage due to static electricity.
- Before removing a unit, after removing the power cord, allow the printer to sit for approx. 1 minute (for capacitor discharging to protect the logic board ass'y from damages).
- Do not touch the timing slit strip film and timing slit disk film. No grease or abrasion is allowed.
- Protect the units from soiled with ink.
- Protect the housing from scratches.
- Exercise caution with the red screws, as follows:
 - i. The red screws of the paper feed motor may be loosened only at replacement of the paper feed motor unit (DO NOT loosen them in other cases).
 - ii. DO NOT loosen the red screws on both sides of the main chassis, securing the carriage shaft positioning (they are not adjustable in servicing).

[To the top](#)



3-2. Special Notes on Repair Servicing

(1) Flexible cable and harness wiring, connection

Be careful of wiring of the flexible cables and harness. Improper wiring or connection may cause breakage of a line, leading to ignition or emission of smoke.

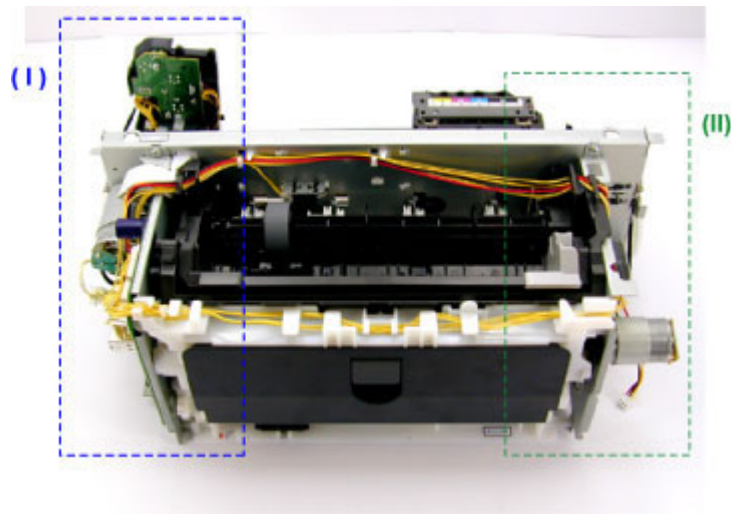

(I) Logic board ass'y and operation panel unit wiring

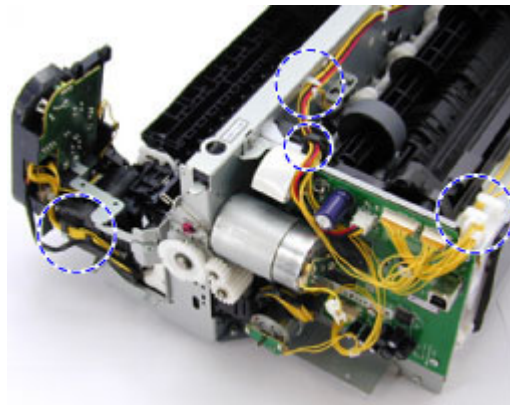

(II) Paper feed motor side wiring

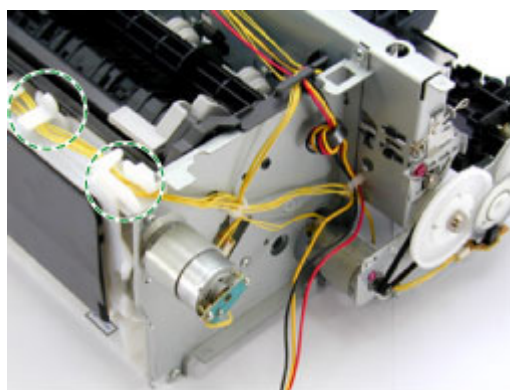

[To the top](#)

← <Part 1: 3. REPAIR, 3-2> →

3-3. Adjustment / Settings

(1) Paper feed motor adjustment

Perform the following adjustments when the paper feed motor unit is replaced:

- 1) When attaching the motor, fasten the screws so that the belt is properly stretched (in the direction indicated by the blue arrow in the figure below).
- 2) After replacement, be sure to perform the service test print, and confirm that no strange noise or faulty print operation (due to dislocation of the belt or gear, or out-of-phase motor, etc.) occurs.

Note: The red screws securing the paper feed motor may be loosened only at replacement of the paper feed motor unit. DO NOT loosen them in other cases.

(2) Gear phase adjustment

In attaching the lift transmission gear (QC1-4327), adjust the phase so that the protrusion of the lift transmission gear (QC1-4327) fits into the recess of the carriage shaft cam R (QC1-4382), as shown in the figure below.

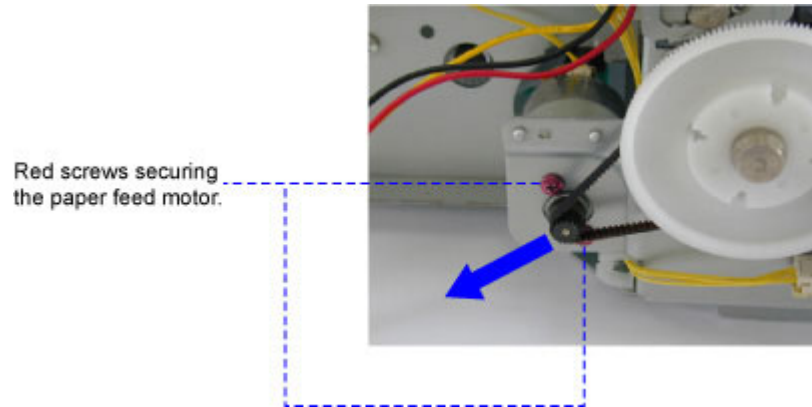

(3) Grease application

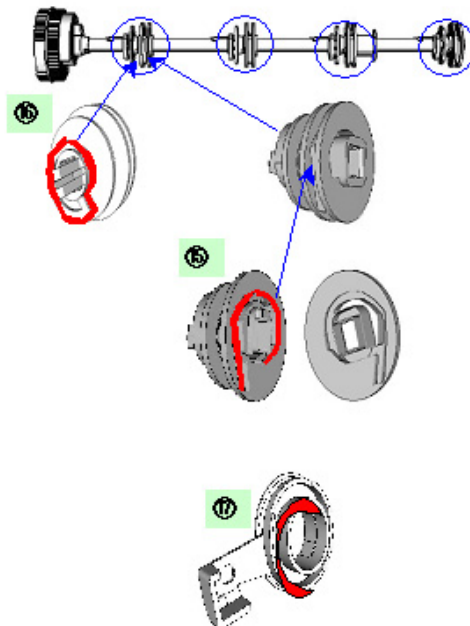
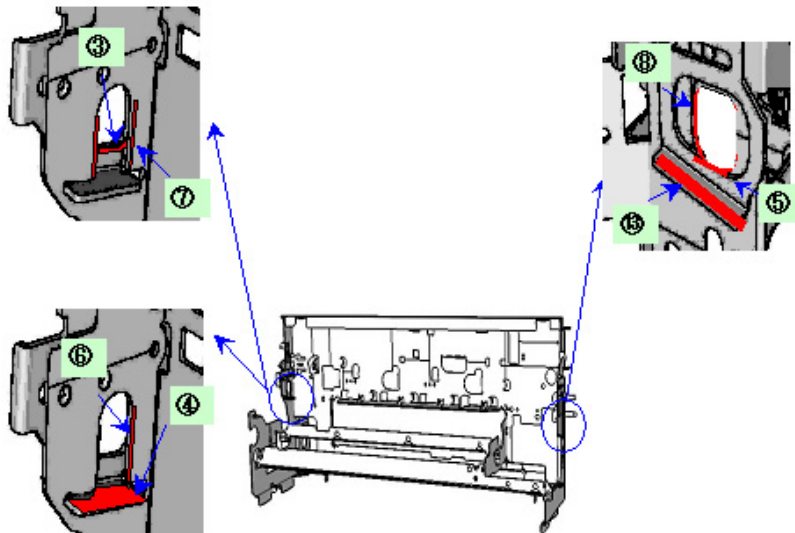
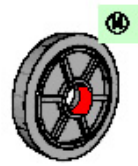
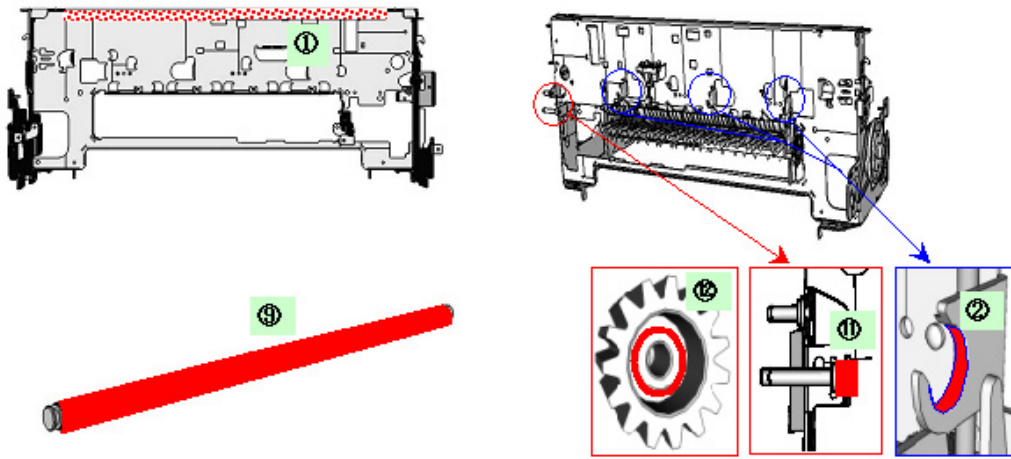

Part name		Where to apply grease / oil	Grease / oil name	Grease / oil amount
Chassis	1	Entire surface the carriage slider contacts	FLOIL KG107A	3 drops
	2	Cam contact portion	FLOIL KG107A	1 drop
	3	Carriage shaft sliding portion	FLOIL KG107A	1 drop
	4	Carriage shaft cam L sliding portion	MOLYKOTE HP300	2 drops
	5	Carriage shaft sliding portion	FLOIL KG107A	1 drop
	6	Carriage shaft sliding portion on the left side of the chassis (at 2 locations)	FLOIL KG107A	1 drop
	7	Carriage shaft cam L sliding portion on the left side of the chassis (at 2 locations)	FLOIL KG107A	2 drops
	8	Carriage shaft sliding portion on the right side of the chassis (at 2 locations)	FLOIL KG107A	1 drop
Carriage shaft	9	Entire surface of the carriage shaft where the carriage unit slides	FLOIL KG107A	200 to 400mg
Carriage shaft spring L	10	Carriage shaft sliding portion (over the area more than 2/3 from the top end of the spring)	FLOIL KG107A	1 drop
Lift gear 2 shaft	11	Outer surface of the stepped portion where the spring slides	MOLYKOTE HP300	1 drop
Lift gear 2	12	Outer surface of the spring sliding bushing	MOLYKOTE HP300	1 drop
Chassis	13	Carriage shaft cam R sliding portion	MOLYKOTE HP300	1 drop
Transmission gear	14	Inner surface	MOLYKOTE HP300	1 drop
Lift shaft	15	Spring sliding portion (4 locations)	FLOIL KG107A	1 drop
	16	Pressure roller ass'y contact portion (4 locations)	FLOIL KG107A	1 drop
Feed roller ass'y	17	Spring contact bushing	FLOIL KG107A	Half drop

Note: 1 drop = 9 to 18 mg

[To the top](#)

← <Part 1: 3. REPAIR, 3-3 (1) to (3)> →

(4) Waste ink counter setting

When the logic board ass'y is replaced, reset the waste ink counter. In addition, according to the waste ink amount, replace the waste ink absorber (the bottom case unit or the ink absorbers). The standard amount for waste ink absorber replacement is given in the table below.

Waste ink amount*1	Bottom case unit or ink absorber replacement
Less than 7%	Not required.
7% or more	Required.

*1: Check the waste ink amount by service test print or EEPROM information print.

[\[See 3.3. Adjustment / Settings. \(6\) Service mode, for details.\]](#)

(5) User mode

Function	Procedures	Remarks
Print head manual cleaning	- Cleaning both black and color: See "Standalone printer operation" below. - Cleaning black or color separately, or both black and color: Perform from the printer driver's Maintenance tab.	
Print head deep cleaning	- Cleaning black or color separately, or both black and color: Perform from the printer driver's Maintenance tab.	
Paper feed roller cleaning	See "Standalone printer operation" below.	
Nozzle check pattern printing	See "Standalone printer operation" below.	Also available from the printer driver's Maintenance tab.
Print head alignment	See "Standalone printer operation" below.	In Custom Settings of the printer driver's Maintenance tab, manual print head alignment (by selecting the optimum values) as with the conventional models can be performed.
Bottom plate cleaning	Perform from the printer driver's Maintenance tab.	Cleaning of the platen ribs when the back side of paper gets smeared.
Print head replacement	The print head is replaceable at the same position as for ink tank replacement. (Open the access cover. When the carriage stops at the center, the print head can be replaced.)	

<Standalone printer operation>

- 1) Turn on the printer.
- 2) Press and hold the Resume/Cancel button until the LED blinks the specified number of times listed in the table below, and release it. The operation starts.

LED blinking	Operation	Remarks
1 time	Print head manual cleaning	
2 times	Nozzle check pattern printing	Set a sheet of plain paper (A4 or letter) in the ASF or the cassette (according to the Paper Feed switch setting).
3 times	Paper feed roller cleaning	
4 times	Automatic print head alignment	Set a sheet of plain paper (A4 or letter) in the ASF.
5 times	Bottom plate cleaning	Fold a sheet of plain paper (A4 or letter) in half crosswise, then unfold and set it in the ASF with the folded ridge facing down.
6 times or more	Unspecified	

(6) Service mode

Function	Procedures	Remarks
Service test print - Model name - ROM version - USB serial number - Waste ink amount - CD-R sensor correction	See "Service mode operation procedures" below.	Set a sheet of A4-, letter-, or larger-sized paper. For print sample, see 3-4. Verification Items, (1) Service test print, <Service test print sample> .
EEPROM initialization	See "Service mode operation procedures" below.	The following items are NOT initialized: - USB serial number - Destination settings - Waste ink counter - CD-R correction value
Waste ink counter reset	See "Service mode operation procedures" below.	If the waste ink amount is 7% or more, replace the bottom case unit, or the ink absorbers.
Destination settings	See "Service mode operation procedures" below.	Other than Japan: iP4000 Japan: iP4100

Note: At the end of the service mode, press the Power button. To protect the media sensor from being dislocated during transportation, the paper lifting plate of the sheet feeder unit will be raised.

<Service mode operation procedures>

- 1) With the printer power turned off, while pressing the Resume/Cancel button, press and hold the Power button. (DO NOT release the buttons. The LED lights in green to indicate that a function is selectable.)
- 2) While holding the Power button, release the Resume/Cancel button. (DO NOT release the Power button.)
- 3) While holding the Power button, press the Resume/Cancel button 2 times, and then release both the Power and Resume/Cancel buttons. (Each time the Resume/Cancel button is pressed, the LED lights alternately in orange and green, starting with orange.)
- 4) When the LED lights in green, press the Resume/Cancel button the specified number of time(s) according to the function listed in the table below. (Each time the Resume/Cancel button is pressed, the LED lights alternately in orange and green, starting with orange.)

Time(s)	LED	Function	Remarks
0 times	Green	Power off	When the print head is not installed, the carriage returns and locks in the home position.
1 time	Orange	Service test print	See 3-4. Verification Items, (1) Service test print.
2 times	Green	EEPROM information print	See 3-4. Verification Items, (2) EEPROM information print.
3 times	Orange	EEPROM initialization	
4 times	Green	Waste ink counter resetting	
5 times	Orange	Destination settings	Proceed to the step 5), and follow the Destination settings procedures.
6 times	Green	Print head deep cleaning	
7 times	Green	CD-R test print	Not used in servicing.
8 times	Orange	CD-R print position correction (horizontal)	Not used in servicing.
9 times	Green	CD-R print position correction (vertical)	Not used in servicing.
10 times or more		Return to the menu selection	

- 5) After the function (menu) is selected, press the Power button. The LED lights in green, and the selected function is performed. (When the operation completes, the printer returns to the menu selection mode automatically.)

<Destination settings procedures>

In the destination settings mode, press the Resume/Cancel button the specified number of time(s) according to the destination listed in the table below, and press the Power button.

Time(s)	LED	Destination
1 time	Orange	Japan: iP4100
2 times	Green	Other than Japan, non-support of CD-R printing (A4): iP4000
3 times	Orange	Other than Japan, non-support of CD-R printing (LTR): iP4000 (LTR)
4 times	Green	Other than Japan, support of CD-R printing (A4): iP4000
5 times	Orange	Other than Japan, support of CD-R printing (LTR): iP4000 (LTR)
6 times or more		Return to the menu selection

Note: After setting the destination, confirm the model name in service test print or EEPROM information print.

[\[See 3.4. Verification Items, \(1\) Service test print, or \(2\) EEPROM information print.\]](#)

[To the top](#)

 <Part 1: 3. REPAIR, 3-3 (4) to (7)> 

3-4. Verification Items

(1) Service test print

<EEPROM information contents>

On the service test print (sample below), confirm the EEPROM information as shown below. (The information is given in the upper portion of the printout.)

	Destination(model name)					
		ROM version				
			USB serial number			
				Reserved for factory use		
					Ink absorber waste ink amount(%)	
						CD-R sensor correction value
iPxxxx	Vx.xx	USB(xxxxxx)	FA=xx xx xx	D=xxx.x	CDR(xxxxxx, xxxxxx)	

<Print check items>

On the service test print (sample below), confirm the following items:

- Check 1, nozzle check pattern: Ink shall be ejected from all nozzles
- Check 2, top of form accuracy: The line shall not extend off the paper.
- Check 3, vertical straight lines: The line shall not be broken.
- Check 4, halftone: There shall be no remarkable streaks or unevenness.
- Check 5, CD-R / automatic print head alignment sensor correction: The results shall be OK.

<Service test print sample>

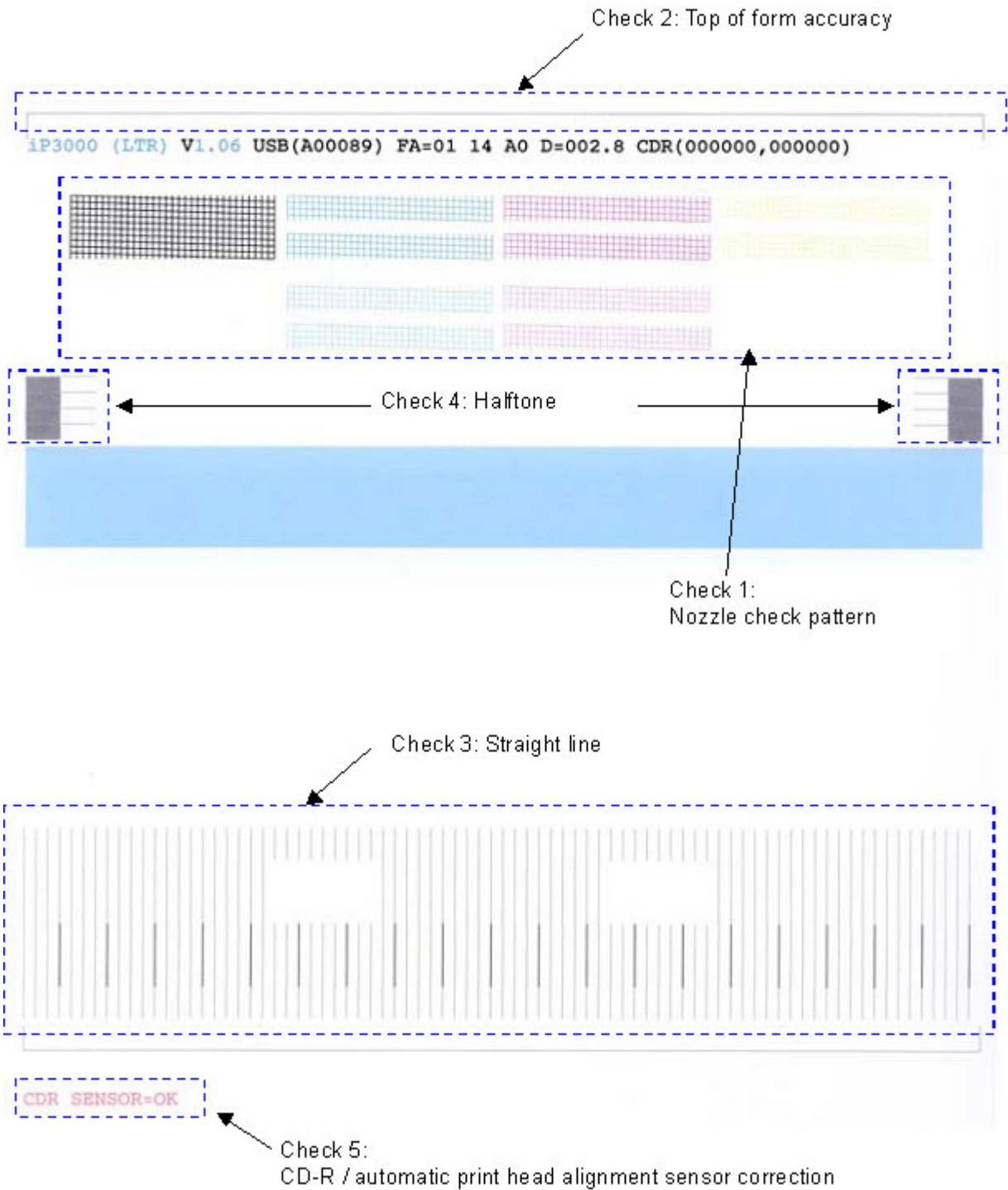

(2) EEPROM information print

<How to read EEPROM information print>

Print sample:

```
iPXXXX V1.02 IF(USB1=1 1284=0) D=004.5 ST=2004/05/27-18:30
ER(ER0=1000 ER1=5100 LPT=2004/06/03-09:09
PC(M=002 R=000 T=001 D=009 C=009)
CLT(BK=2004/06/19-18:30 CL=2004/06/19-18:30)
CH=00002 CT(BK1=040 BK2=020 C=109 M=012 Y=113) IS(BK1=1 BK2=0 C=1 M=1 Y=1)
P_ON(S=00009) A_REG=1 M_REG=0
UR(A(BKoe)=+01 B(Coe)=-01 C(Moe)=+01 D(SCoe)=-01 E(SMoe)=+01 F(PBKoe)=+01
G(BKbi)=+01 H(CLbi)=+01 I(BK-CL)=+01 J(SCLbi)=+01 K(C-SC)=+01 L(M-SM)=+01)

WP=0024 CDIN(LG=001 PB=000) MSD(015)
PAGE(All=00083 PP=00035 HR+MP=00003 PR+SP+SG =00000 GP =00000 PC=00000 EV=00000)
UCPAGE(All=00083 PP=00035 HR+MP=00003 PR+SP+SG =00000 GP =00000 PC=00000 EV=00000)
BPPAGE(All=00083 BSGP=00003 PC=00000)
```

CDPAGE(All=000) EDGE=00083 L=00000 CDR=00000
CDRP=(-00005,-00029) CDRS=(000)
Head TempBK=18.5 Head TempC=17.5 Env Temp=30.0 FF(3F 3F 3F)

HDEEPROM
V0001
SN=0318-A43D
LN(00000 00000 00001 00003 00001 00000 00000)
ID=00
IL=(BK=000 C=000 M=000 Y=000 C2=000 M2=000 PBK=000)

Printed items:

1. Model name
2. ROM version
3. Connected I/F (USB1/1284)
4. Waste ink amount
5. Installation date
6. Operator call/service call error record
7. Last printing time
8. Purging count (manual/deep cleaning/timer/dot count/ink tank or print head replacement)
9. Cleaning time (BK/CL)
10. Print head replacement count
11. Ink tank replacement count (pigment BK/dye BK/C/M/Y)
12. Ink status (pigment BK/dye BK/C/M/Y)
13. Power-on count (soft)
14. Automatic print head alignment by user
- 14-1. Manual print head alignment by user
15. User print head alignment values (Bkoe/Coe/Moe/SCoe/SMoe/PBKoe/BKbi/CLbi/BK-PCBK/SCLbi/C-SC/M-SM)
16. Wiping count
17. Camera Direct Print-supported device connection record
18. Longest period where printing stops
19. ASF feed pages (total, plain paper, High Resolution Paper & Matte Photo Paper, Photo Paper Pro & Photo Paper Plus Glossy & Photo Paper Plus Semi-gloss, Glossy Photo Paper, Postcard, Envelope)
20. U-turn cassette feed pages (total, plain paper, High Resolution Paper & Matte Photo Paper, Photo Paper Pro & Photo Paper Plus Glossy & Photo Paper Plus Semi-gloss, Glossy Photo Paper, postcard, envelope)
21. Auto duplex print pages (total, Photo Paper Plus Double Sided, postcard)
22. Camera Direct print pages (total)
23. Borderless print pages
24. L & 4x6 print pages
25. Number of CD-Rs printed
26. CD-R print position adjustment
27. CD-R sensor correction value
28. Print head temperature (BK/CL)
29. Inside temperature
30. Line inspection information

HDEEPROM
31. Version
32. Serial number
33. Lot number
34. Print head ID
35. Ink ejection level (BK/C/M/Y/C2/M2/PBK)

[To the top](#)



4. PRINTER TRANSPORTATION

This section describes the procedures for transporting the printer for returning after repair, etc.

- 1) In the service mode, press the Power button to finish the mode, and confirm that the paper lifting plate of the sheet feeder unit is raised.
- 2) Keep the print head and ink tanks installed in the carriage.
[\[See Caution 1 below.\]](#)
- 3) Turn off the printer to securely lock the carriage in the home position. (When the printer is turned off, the carriage is automatically locked in place.)
[\[See Caution 2 below.\]](#)
- 4) To further secure the carriage to prevent movement from the home position during transportation, make and use a fixing tool in the following procedures:
 - i. Fold an A4-sized paper 5 times, and wrap it twice with tape, as shown in Figure A below (to prevent the fixing tool from caught into the inside of the printer).
 - ii. Insert the fixing tool between the carriage and the main case unit, and securely fix it with tape, as shown in Figures B and C below.

Note: The tape should be similar to the polyester tape used at shipment, which will not easily be torn or removed, or leave adhesive on the unit when removed.

Leave a sufficient length of tape to fix the tool so that the tape end is easily seen even when the access cover is closed, so that the user will remove the tool from the returned printer without fail.

Figure A:



Figure B:



Figure C:



Caution:

- (1) If the print head is removed from the printer and left alone by itself, ink (especially the pigment black ink) is likely to dry. For this reason, keep the print head installed in the printer even during transportation.
- (2) Securely lock the carriage in the home position, to prevent the carriage from moving and applying stress to the carriage flexible cable, or causing ink leakage, during transportation.

Memo:

If the print head must be removed from the printer and transported alone, perform the following:

- (1) Install both the black and color ink tanks (to prevent the nozzles from drying).
- (2) Attach the protective cap (used when the packing was opened) to the print head (to protect the print head face from damage due to shocks).

[To the top](#)



Part 2

TECHNICAL REFERENCE



1. NEW TECHNOLOGIES

(1) Multi-paper handling

Paper feeding through the auto sheet feeder and the front cassette, automatic duplex printing, and CD-R / DVD-R direct printing is available as a standard feature.

- Auto sheet feeder: Supports credit card size and sticker sheets as well as conventional paper types and sizes.
- Front cassette: Except credit card size and sticker sheets, supports the same types and sizes of paper as the auto sheet feeder.
- Automatic duplex printing unit built-in: By using Photo Paper Plus Double Sided, a photo album can be created automatically.
- CD-R / DVD-R direct printing unit built-in: By incorporating CD-R / DVD-R tray feeder functionality into the printer, CD-R / DVD-R direct printing can be performed without using a CD-R tray feeder.

Front loading and operation without any lever settings offers easy and quick printing.

(2) New design

- Complete renovation to a new generation printer design
- Elegant-looking housing with mirror finished surface
- Various features and functionality in a compact body comparative to the i850 in size.

(3) Automatic duplex printing unit installed as a standard feature

For the following paper types and sizes, automatic duplex printing can be performed:

- Type: Plain paper, Super White Paper (double-sided plain paper), Photo Paper Plus Double Sided (double-sided glossy photo paper)
- Size: A5, B5, 5" x 7", A4, LTR

[To the top](#)



2. CLEANING MODE AND AMOUNT OF INK PURGED

To prevent printing problems due to bubbles, dust, or ink clogging, print head cleaning is performed before the start of printing, except in the following cases:

- Cleaning on arrival: Performed when the access cover is closed.
- Cleaning by dot count: Performed after ejection of paper (or after printing on the back side of paper when auto duplex printing is performed).
- Manual cleaning / deep cleaning: Performed manually.

<Cleaning mode list>

Black: Pigment-based black

Color: Dye-based black, cyan, magenta, yellow

Condition	Details	Amount of ink used (g)	Est. required time (sec.)
On arrival of the printer (All in sequence)	First and second cleaning after shipped from the plant.	0.45 (Black) 1.50 (Color)	70
Dot count cleaning*1 (Black/Color)	When the specified number of dots are printed since the previous Black/Color cleaning. (Cyan and magenta dots are counted by large and small nozzles separately.)	0.14 (Black) 0.50 (Color)	30 (Black) 35 (Color)
Timer cleaning - 0*2 (Black only)	If 24 to 60 hours have elapsed since the previous Black cleaning till the start of the next printing.	0.14 (Black)	30 (Black)
Timer cleaning - 1 (Black only)	If 60 to 96 hours have elapsed since the previous Black cleaning till the start of the next printing.		
Timer cleaning - 2 (Black only)	If 96 to 120 hours have elapsed since the previous Black cleaning till the start of the next printing.		
Timer cleaning - 3*3 (Black/Color)	If 120 to 336 hours have elapsed since the previous Black/Color cleaning till the start of the next printing.	0.14 (Black) 0.50 (Color)	30 (Black) 35 (Color)
Timer cleaning - 4 (All in sequence)	If 336 to 504 hours have elapsed since the previous Black/Color cleaning till the start of the next printing.	0.45 (Black) 1.00 (Color)	60
Timer cleaning - 5 (All in sequence)	If 504 to 720 hours have elapsed since the previous Black/Color cleaning till the start of the next printing.		60
Timer cleaning - 6 (All in sequence)	If 720 to 1,080 hours have elapsed since the previous Black/Color cleaning till the start of the next printing.		60
Timer cleaning - 7 (All in sequence)	If 1,080 to 2,160 hours have elapsed since the previous Black/Color cleaning till the start of the next printing.	0.78 (Black) 1.00 (Color)	60
Timer cleaning - 8 (All in sequence)	If 2,160 to 4,320 hours have elapsed since the previous Black/Color cleaning till the start of the next printing.	1.58 (Black) 1.00 (Color)	65
Timer cleaning - 9 (All in sequence)	If 4,320 to 8,640 hours have elapsed since the previous Black/Color cleaning till the start of the next printing.	1.58 (Black) 1.00 (Color)	65
Timer cleaning - 10 (All in sequence)	If 8,640 or longer hours have elapsed since the previous Black/Color cleaning till the start of the next printing.		65
At print head replacement (All in sequence)	When the print head is removed and installed.	0.45 (Black) 1.50 (Color)	70
At ink tank replacement (Black/Color)		0.30 (Black) 1.00 (Color)	45 (All in sequence) 30 (Black) 35 (Color)

Manual cleaning (Black/Color/All at the same time)	- Via the operation panel (All at the same time only) - Via the printer driver (Selectable from Black, Color, or All at the same time)	0.14 (Black) 0.50 (Color)	45 (All at the same time) 30 (Black) 40 (Color)
Deep cleaning (Black/Color/All at the same time)	Via the printer driver (Selectable from Black, Color, or All at the same time)	1.58 (Black) 1.00 (Color)	65 (All at the same time) 45 (Black) 50 (Color)
If the print head has not been capped before power-on (All in sequence)		0.30 (Black) 1.00 (Color)	45 (All in sequence)

- *1: The dots since the previous cleaning are counted by Black and Color separately. For this reason, the cleaning mode may differ according to Black or Color.
- *2: When 24 to 60 hours have elapsed since the previous Black cleaning, timer cleaning - 0 is performed. However, this cleaning will be conducted up to 5 times from the printer installation, and no further timer cleaning - 0 will be performed.
- *3: The period of time since the previous cleaning is counted by Black and Color separately. For this reason, the cleaning mode may differ according to Black or Color.

[To the top](#)



3. FAQ (Problems Specific to the iP4000 and Corrective Actions)

No.	*	Function	Phenomenon	Condition	Cause	Corrective action	Possible call or complaint
1	C	Print results	Margin (approx. 0.3mm)	<ul style="list-style-type: none"> - Paper feeding from the cassette, Photo Paper Plus Double Sided (A4), borderless printing, printing on the back side of paper - In the low temperature and low humidity environment 		<ul style="list-style-type: none"> - In the printer driver, increase the amount of extension. - Change the paper feeding method from the cassette to the auto sheet feeder. 	<ul style="list-style-type: none"> - A margin appears on printouts. - Paper feeds at an angle.
2	B	Print results	<ul style="list-style-type: none"> - Skewed paper feeding - Printing on the platen 	<ul style="list-style-type: none"> - Plain paper - In the high temperature and high humidity environment 		<ul style="list-style-type: none"> - If paper is curled, straighten it. - Try printing on the other side of paper. 	<ul style="list-style-type: none"> - Paper feeds at an angle. - Printing is performed on the platen. - The back side of paper gets smeared.
3	B	Print results	Variation in the top of form accuracy	<ul style="list-style-type: none"> - A5 or legal size - In the low temperature and low humidity environment - Not solved even when the number of sheets stacked in the auto sheet feeder or the cassette is reduced 	Due to decrease of paper feed capability in the low temperature and low humidity environment	<ul style="list-style-type: none"> - Set the top margin to 4mm or more. 	<ul style="list-style-type: none"> - Print start position varies.
4	B	Print results	<ul style="list-style-type: none"> - Skewed paper feeding - Margin 	<ul style="list-style-type: none"> - Photo Paper Plus Double Sided - 2L size (Japan only) 		<ul style="list-style-type: none"> - In the printer driver, increase the amount of extension. - Change the paper feeding method from the cassette to the auto sheet feeder. 	<ul style="list-style-type: none"> - A margin appears on printouts. - Paper feeds at an angle.
5	C	Safety during transportation	Carriage lock lever dislocation	<ul style="list-style-type: none"> - With the print head and ink tanks installed - The phenomenon occurred in the freight handling test. 		When returning the repaired printer to the user, insert the fixing tool (A4 plain paper folded 5 times) between the main case and the carriage, and fix it with tape. [See Part 1, 4. PRINTER TRANSPORTATION]	During transportation for return after repair, Ink dries, and no ink is ejected.
6	A	Print results	Soiling on the back side of paper (lines or streaks parallel to the paper feed direction)	<ul style="list-style-type: none"> - After continuous borderless printing of small sized paper (such as 4 x 6), when a larger sized paper (such as A4) is printed. - With Photo Paper Plus Double Sided or postcards, the phenomenon is likely to be noticeable and to be complained of by users, as printing is performed on both sides of such paper. 	In borderless printing, printing is performed to the size slightly larger than the paper size, and ink off the paper is absorbed by the platen's ink absorber. Absorbed ink may attach to the platen rib(s) after several dozen sheets are printed, causing soiling at the leading edge of paper or on the back side of paper.	<ol style="list-style-type: none"> 1. Perform Bottom plate cleaning (from the printer driver) up to 3 times*1. *1: Change the paper in each Bottom plate cleaning. The cleaning can end when paper does not get any soiling. 2. If soiling on the paper still remains after 3 times of Bottom plate cleaning, wipe the platen rib(s) and their surroundings with a cotton swab. 	<ul style="list-style-type: none"> - Paper gets smeared. - The back side of paper gets smeared.
			Soiling on paper in automatic duplex printing (lines or streaks perpendicular to the paper feed direction)	- Automatic duplex printing (Photo Paper Plus Double Sided, postcards, plain paper)	On the rib(s) inside the sheet feed unit used for duplex printing, ink mist may accumulate, smearing paper.	Temporary operational solution: Cancel automatic duplex printing, and manually print each side of paper.	<ul style="list-style-type: none"> - Paper gets smeared. - The back side of paper gets smeared.

7	B	Print results				<p>Cleaning by user:</p> <ol style="list-style-type: none"> 1. Perform Bottom plate cleaning (from the printer driver) up to 3 times*1. <p>*1: Change the paper in each Bottom plate cleaning. The cleaning can end when paper does not get any soiling.</p> <ol style="list-style-type: none"> 2. If soiling on the paper still remains after 3 times of Bottom plate cleaning, wipe the platen rib(s) and their surroundings with a cotton swab. <p>If the phenomenon persists after conducting 1 and 2, servicing is required.</p> <p>Service:</p> <p>Wipe any soiling or dirt off from the sheet feed unit and the bottom case unit ribs*2.</p>	cleaning was performed, and the platen ribs were cleaned with cotton swab, paper gets smeared.
8	C	Print results	Scratches on paper	<ul style="list-style-type: none"> - PP-101D, PP-101, PR-101, SG-101, etc. - Paper feeding from the cassette - Multiple number of sheets loaded 	<ul style="list-style-type: none"> - Paper is scratched. - Marks appear on printed paper. 	<ul style="list-style-type: none"> - Change the paper feeding method from the cassette to the auto sheet feeder. - If automatic duplex printing is performed, cancel it, and, by setting only a single sheet of paper in the auto sheet feeder, manually print each side of paper. 	Scratches on the PF return lever due to paper feeding from the cassette, and duplex printing path.

*2: Locations to clean in servicing when soiling on paper in automatic duplex printing persists:

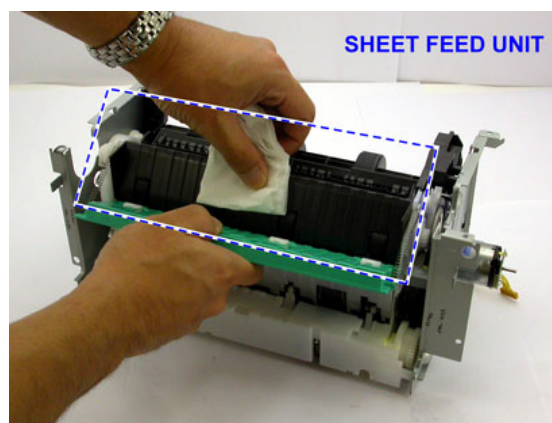
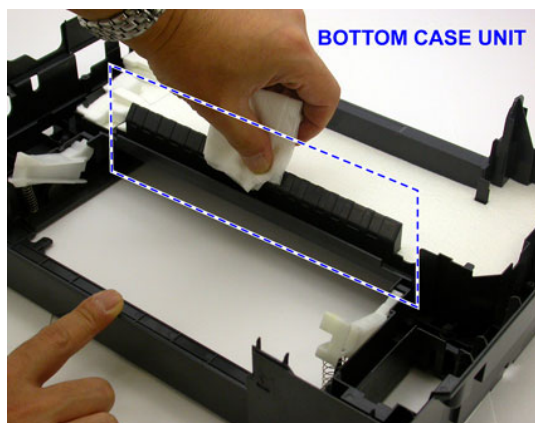

* Occurrence level:

- A: The symptom is likely to occur frequently. (Caution required)
- B: The symptom may occur under certain conditions, but likeliness is assumed very low in practical usage.
- C: The symptom is unlikely to be recognized by the user, and no practical issues are assumed.

[To the top](#)

Part 3

APPENDIX



PIXMA iP4000 Specifications

<Printer>

Type	Desktop serial color bubble jet printer			
Paper feeding method	Auto sheet feed (ASF, cassette, automatic duplex printing, CD-R printing*1)			
Resolution	4,800 x 1,200dpi (Max.)			
Throughput		Draft	Standard	
	Black (Fine Black)	25ppm	15ppm	
	Color (Fine Color)	17ppm	11ppm	
Printing direction	Bi-directional, uni-directional			
Print width	Max. 203.2mm (216mm in borderless printing)			
Interface	USB 2.0 Full Speed IEEE1284			
ASF stacking capacity	Plain paper: Max. 13mm (Approx. 150 sheets of 65g/m ² paper)			
Paper weight	64 to 105g/m ²			
Detection functions	Cover open, Presence of print head, Remaining ink amount (optical / dot count), Printing position, Paper presence, Paper end sensor, Waste ink amount, Internal temperature, Pick-up roller, Paper feed roller position, Carriage position, Head-to-paper distance, Supported camera direct printing device, Presence of CD-R, Supported paper size for duplex printing, Openning / Closing of paper output tray			
Noise during printing (Highest print quality)	- Highest print quality settings: Approx. 35dB - Quiet mode: TBD			
Environmental requirements	During operation	Temperature	5C to 35C (41F to 95F)	
		Humidity	10%RH to 90%RH (no condensation)	
	Non operation	Temperature	0C to 40C (32F to 104F)	
		Humidity	5%RH to 95%RH (no condensation)	
Power supply	Power supply voltage, frequency	Power consumption	Standby	Power-off
	AC 100 to 120V, 50/60Hz	Approx. 16W	Approx. 0.5W	Approx. 0.25W
	AC 220 to 240V, 50/60Hz	Approx. 16W	Approx. 0.5W	Approx. 0.25W
External dimensions	Printer: With the paper support and output tray retracted: Approx. 418 (W) x 286 (D) x 170 (H)mm With the paper support and output tray extended: Approx. 418 (W) x 555 (D) x 325 (H)mm			
Weight	Approx. 6.7kg, not including print head and optional units			
Related standards (Printer, Adapter)	Electromagnetic radiance: VCCI, FCC, IC, CE Mark, Taiwan EMC, C-tick, CCC (EMC), Korea MIC, Gost-R Electrical safety: Electrical Appliance and Material Safety Law (DENAN), UL, C-UL, CB Report, GS, CE Mark, Gost-R, FT, SASO, CCC, SPRING, Korea EK, IRAM (Argentine) Environmental regulations: RoHS (EU), WEEE (EU), Korea Package Recycle Law, Green Point (Germany), Energy Star, Eco Mark, Law on Promoting Green Purchasing			
Serial number location	On the carriage flexible cable holder (visible when the access cover is open.)			
Remaining ink amount detection	Available (automatic detection by optical method and dot count, enabled at default)			
Paper type detection	Not available			
Print head alignment	Available (automatic or manual alignment via driver utilities, or the Resume/Cancel button in Camera Direct Printing, automatic alignment at default)			

*1: Only for CD-R printing supported regions

<Print head>

Type	Single head with 5 removable ink tanks (each color)
Print head	Black: 320 nozzles in 2 vertical lines (600dpi), 30pl (pigment-based black) Color: 256 nozzles in 2 vertical lines per color x 6 (1,200dpi), 5.5pl (cyan, magenta, yellow, dye-based black) / 2.5pl (cyan, magenta)
Ink color	Pigment-based black, Dye-based black, cyan, magenta, yellow
Ink tank	BCI-3eBK (pigment-based), BCI-6C/M/Y/BK (dye-based)
Weight (Net)	Print head, approx. 60g
Supply method	As a service part (not including ink tanks)
Part number	QY6-0049-000

[To the top](#)