

# brother

P-touch

## SERVICE MANUAL

MODEL: QL-570



MECHANISMS & ELECTRONICS

## **PREFACE**

This publication is a service manual covering the specifications, theory of operation, disassembly/reassembly procedure, and troubleshooting the Brother QL-570. It is intended for service personnel and other concerned persons to accurately and quickly provide after-sale service for our QL-570.

To perform appropriate maintenance so that the machine is always in best condition for the customer, the service personnel must adequately understand and apply this manual.

This manual is made up of four chapters and appendices.

<b>CHAPTER I</b>	<b>SPECIFICATIONS</b>
<b>CHAPTER II</b>	<b>THEORY OF OPERATION</b>
<b>CHAPTER III</b>	<b>DISASSEMBLY AND REASSEMBLY</b>
<b>CHAPTER IV</b>	<b>TROUBLESHOOTING AND ERROR MESSAGE</b>
<b>APPENDIX 1.</b>	<b>MAINTENANCE SOFTWARE OPERATION</b>

© Copyright Brother 2007

All rights reserved.

No part of this publication may be reproduced in any form or by any means without permission in writing from the publisher.

Specifications are subject to change without notice.

# CONTENTS

<b>CHAPTER I SPECIFICATIONS .....</b>	<b>I-1</b>
1.1 MECHANICAL SPECIFICATIONS .....	I-1
1.1.1 External Appearance .....	I-1
1.1.2 Keyboard.....	I-1
1.1.3 Display .....	I-2
1.1.4 Printing Mechanism .....	I-2
1.1.5 Thermal Tape.....	I-3
1.1.6 Cutter .....	I-4
1.1.7 PC Interface .....	I-4
1.2 ELECTRONICS SPECIFICATIONS .....	I-4
1.2.1 Character Generator.....	I-4
1.2.2 Power Supply.....	I-4
<b>CHAPTER II THEORY OF OPERATION .....</b>	<b>II-1</b>
2.1 OUTLINE OF MECHANISMS .....	II-1
2.1.1 Print Mechanism .....	II-1
2.1.2 Press Contact and Release Mechanism of Thermal Head .....	II-2
2.1.3 Tape Feed Mechanism .....	II-3
2.1.4 Automatic Tape Full Cutter Mechanism .....	II-4
2.1.5 Cover Open (Cover Lock) Sensor .....	II-5
2.2 OUTLINE OF CONTROL ELECTRONICS .....	II-6
2.2.1 Main PCB ASSY .....	II-6
2.2.2 Media Type Detect Switch PCB (Media PCB ASSY) .....	II-6
2.2.3 Media Position Detect Sensor PCB (Tape Sensor PCB ASSY).....	II-6
2.2.4 Key, LED PCB (SB PCB ASSY) .....	II-7
2.2.5 Cutter Sensor (Cutter Home Position Detect Sensor).....	II-7
2.2.6 Media Feed Motor (Tape Feed Motor ASSY).....	II-7
2.2.7 Full Cutter Motor (Cutter Motor ASSY).....	II-7
2.2.8 Thermal Head .....	II-7

2.3	MAIN PCB .....	II-8
2.3.1	Logic Components .....	II-9
[ 1 ]	CPU .....	II-9
[ 2 ]	EEPROM .....	II-9
2.3.2	Key, LED Circuit.....	II-9
2.3.3	Head and Motor Power Supply ON/OFF Circuit.....	II-10
2.3.4	Full Cutter Motor Driver Circuit and Media Feed Motor Driver Circuit.....	II-11
2.3.5	Media Type Detect Sensor Circuit, Media Position Detect Sensor Circuit and Cover Open Sensor Circuit .....	II-12
2.3.6	Head Temperature Detect Circuit .....	II-15
2.3.7	Cutter Home Position Detect Sensor Circuit .....	II-15
2.3.8	Reset Circuit .....	II-16
2.3.9	USB Interface Circuit .....	II-16
<b>CHAPTER III DISASSEMBLY AND REASSEMBLY .....</b>		<b>III-1</b>
3.1	SAFETY PRECAUTIONS .....	III-1
3.2	TIGHTNING TORQUE LISTS .....	III-2
3.3	LUBRICATION POINTS LIST .....	III-3
3.4	DISASSEMBLY PROCEDURE.....	III-5
[ 1 ]	Removing the Top Cover and Thermal Tape .....	III-5
[ 2 ]	Removing the Front Cover and Tray S.....	III-7
[ 3 ]	Removing the Power Supply ASSY and Main PCB ASSY.....	III-8
[ 4 ]	Removing the Sub ASSY Inlet.....	III-12
[ 5 ]	Removing the Media PCB ASSY.....	III-13
[ 6 ]	Removing the Side Cover L, R .....	III-14
[ 7 ]	Removing the Panel Cover .....	III-17
[ 8 ]	Removing the Upper Cover .....	III-19
[ 9 ]	Removing the Mecha ASSY .....	III-21
[ 10 ]	Removing the Cutter Unit ASSY.....	III-22
[ 11 ]	Disassembly of the Mecha ASSY .....	III-23
3.5	REASSEMBLING PROCEDURE.....	III-28
[ 1 ]	Reassembling the Mecha ASSY .....	III-28
[ 2 ]	Installing the Cutter Unit ASSY.....	III-34

[ 3 ]	Installing the Mecha ASSY .....	III-35
[ 4 ]	Installing the Upper Cover .....	III-36
[ 5 ]	Installing the Panel Cover.....	III-39
[ 6 ]	Installing the Side Cover L, R .....	III-42
[ 7 ]	Installing the Media PCB ASSY.....	III-44
[ 8 ]	Installing the Sub ASSY Inlet.....	III-44
[ 9 ]	Installing the Power supply ASSY and Main PCB ASSY .....	III-46
[ 10 ]	Installing the Front Cover and Tray S.....	III-50
[ 11 ]	Installing the Top Cover and Thermal Tape .....	III-51
[ 12 ]	Demonstration Print and Final Check.....	III-53

**CHAPTER IV TROUBLESHOOTING AND ERROR MESSAGE..... IV-1**

4.1	PRECAUTIONS .....	IV-1
4.2	AFTER REPAIRING.....	IV-1
4.3	LED CONTROL IN DIFFERENT SITUATIONS AND MEASURE AGAINST ERRORS.....	IV-2
4.4	ERROR MESSAGE .....	IV-3
4.5	TROUBLESHOOTING FLOWS .....	IV-6
[ 1 ]	Printing is performed with specific dots omitted .....	IV-6
[ 2 ]	The tape is not detected correctly .....	IV-7
[ 3 ]	LED does not turn on.....	IV-8
[ 4 ]	No printing is performed .....	IV-9
[ 5 ]	The interface malfunction .....	IV-9
[ 6 ]	The tape is not cut .....	IV-10
[ 7 ]	The tape is not fed correctly .....	IV-11

**APPENDIX 1 MAINTENANCE SOFTWARE OPERATION..... 1**

APPENDIX 1.1	Purpose and Use Procedure of the Reset Software Tool (ql500tstReset.exe).....	3
APPENDIX 1.2	Setting and Use Procedures of the Maintenance Software Tool (ql570tstSE.exe).....	6
APPENDIX 1.3	Use Procedure of the VR Adjustment Tool (ql500tstVRAdjust.exe) .....	25
APPENDIX 1.4	Auto Power-OFF Setting Tool (autopoff.exe).....	31



### 1.1.3 Display

[ 1 ]	Display type	LED 1 (ON/OFF: Green light ON/OFF, Error: Red light blinking, Cover Opened: Orange light ON, Cooling: Orange light blinking)
-------	--------------	---

### 1.1.4 Printing Mechanism

[ 1 ]	Print method	Direct thermal printing with thermal head Printing on thermal paper tape, and printing on thermal paper and thermal plastic tape (with fixed head and tape feeding)
[ 2 ]	Highest printing speed	Max. 68 labels/min. (Standard address labels)
[ 3 ]	Print head Type	Thick film thermal head 720 dots by one row
	Resolution	300 dpi

### 1.1.5 Thermal Tape

[ 1 ] Tape Roll type (Die cut and free length)

[ 2 ] Type and size of die cut tape

Type of tape	Label size (W x H)	Roll overall width	Number of label sheets
Standard Address	29mm x 90mm	32mm	400 sheets/roll
Large Address	38mm x 90mm	42mm	400 sheets/roll
Small Address	62mm x 29mm	66mm	800 sheets/roll
Shipping	62mm x 100mm	66mm	300 sheets/roll
Multi purpose	17mm x 54mm	19mm	400 sheets/roll
File Folder	17mm x 87mm	19mm	300 sheets/roll
CD/DVD	OD $\phi$ 58mm ID $\phi$ 16mm	66mm	100 sheets/roll
Square Paper	23mm x 23mm	32mm	1000 sheets/roll
Round Paper 12	OD $\phi$ 12mm	32mm	1200 sheets/roll
Round Paper 24	OD $\phi$ 24mm	32mm	1000 sheets/roll
Standard Address (For supply with machine)	29mm x 90mm	32mm	100 sheets/roll

[ 3 ] Type and size of free length tape

Type of tape	Roll width	Roll overall width	Effective length of roll
Continuous Length Paper 12	12mm	32mm	30.48m
Continuous Length Paper 29	29mm	32mm	30.48m
Continuous Length Paper 62	62mm	66mm	30.48m
Continuous Length Paper 62 White Removable	62mm	66mm	30.48m
Continuous Length Paper 62 Yellow Removable	62mm	66mm	30.48m
Continuous Length Film-White 29	29mm	32mm	15.24m
Continuous Length Film-White 62	62mm	66mm	15.24m
Continuous Length Film-Yellow 62	62mm	66mm	15.24m
Continuous Length Film-Clear 62	62mm	66mm	15.24m
Continuous Length Paper 62 (For supply with machine)	62mm	66mm	8m



### 1.1.6 Cutter

[ 1 ] Tape cutting Automatic cut

### 1.1.7 PC Interface

[ 1 ] Method USB  
Standard USB Standard Ver.2.0 Full speed

[ 2 ] Supported OS Microsoft Windows 2000 Professional  
Microsoft Windows XP Professional  
Microsoft Windows XP Home Edition  
Microsoft Windows Vista

[ 3 ] Printer emulation PT CBP (Brother original)

[ 4 ] Accessories  
Editor Dedicated editor is included.  
USB IF cable Standard USB cable is included.

## 1.2 ELECTRONICS SPECIFICATIONS

### 1.2.1 Character Generator

*Note: Character generator feature is not provided for QL-570.*

[ 1 ] Demonstration printing  
Press the Feed button once while pressing and holding the power supply key when power is off, and then release the ON/OFF button. Demonstration printing will be started.

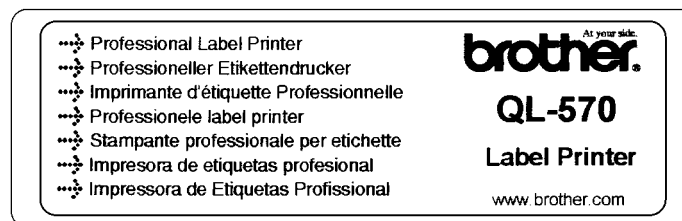

Fig. 1.2-1 Demonstration Printing

### 1.2.2 Power Supply

Integral switching power supply U.S.A. / Canada: 120V AC 60Hz  
Europe, Other regions: 220V to 240V AC 50/60Hz

## CHAPTER II THEORY OF OPERATION

### 2.1 OUTLINE OF MECHANISMS

#### 2.1.1 Print Mechanism

##### ■ Structure of Thermal Head

This machine adopts direct thermal printing system. The thermal head consists of 720 pieces of heating elements arrayed in vertical single row as shown in the Fig.2.1-1. The dimension of each heating element is vertical length 0.0847 (0.0847mm pitch) x horizontal width 0.13mm.

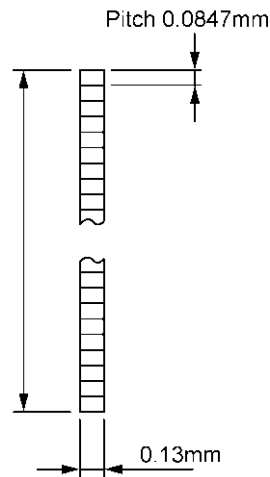

Fig. 2.1-1 Heating Elements of Thermal Head

##### ■ Printing Process

A thermal tape is pressed against the thermal head in the printing process by the force comes from a nip between the cylindrical rubber platen and the thermal head. At this timing, voltage is applied selectively to 720 pieces of heating elements arrayed on the thermal head. By this voltage application, the heating elements generate heat and the thermal tape develops dots by itself at heat sensing points. After application of voltage the thermal tape is fed to the next printing position by the platen (0.0847mm). This printing cycle is repeated and characters and geometries are printed on the tape.

One time travel distance (0.0847mm) is shorter than the width of a heating element (0.13mm), so that continuous printing cycle can print characters and geometries on a tape by developing dots with no gap.

### 2.1.2 Press Contact and Release Mechanism of Thermal Head

The head ASSY is pressed firmly against on the platen ASSY by the force of head spring L. When open the top cover, the release gear and release shaft are turned via link lever and platen release lever and the release shaft presses down the head ASSY. This movement releases the head ASSY from the platen ASSY. Tape can be set under this condition.

To press the head ASSY firmly against the platen ASSY, close the top cover. This close motion can automatically press the head ASSY firmly against the platen ASSY.

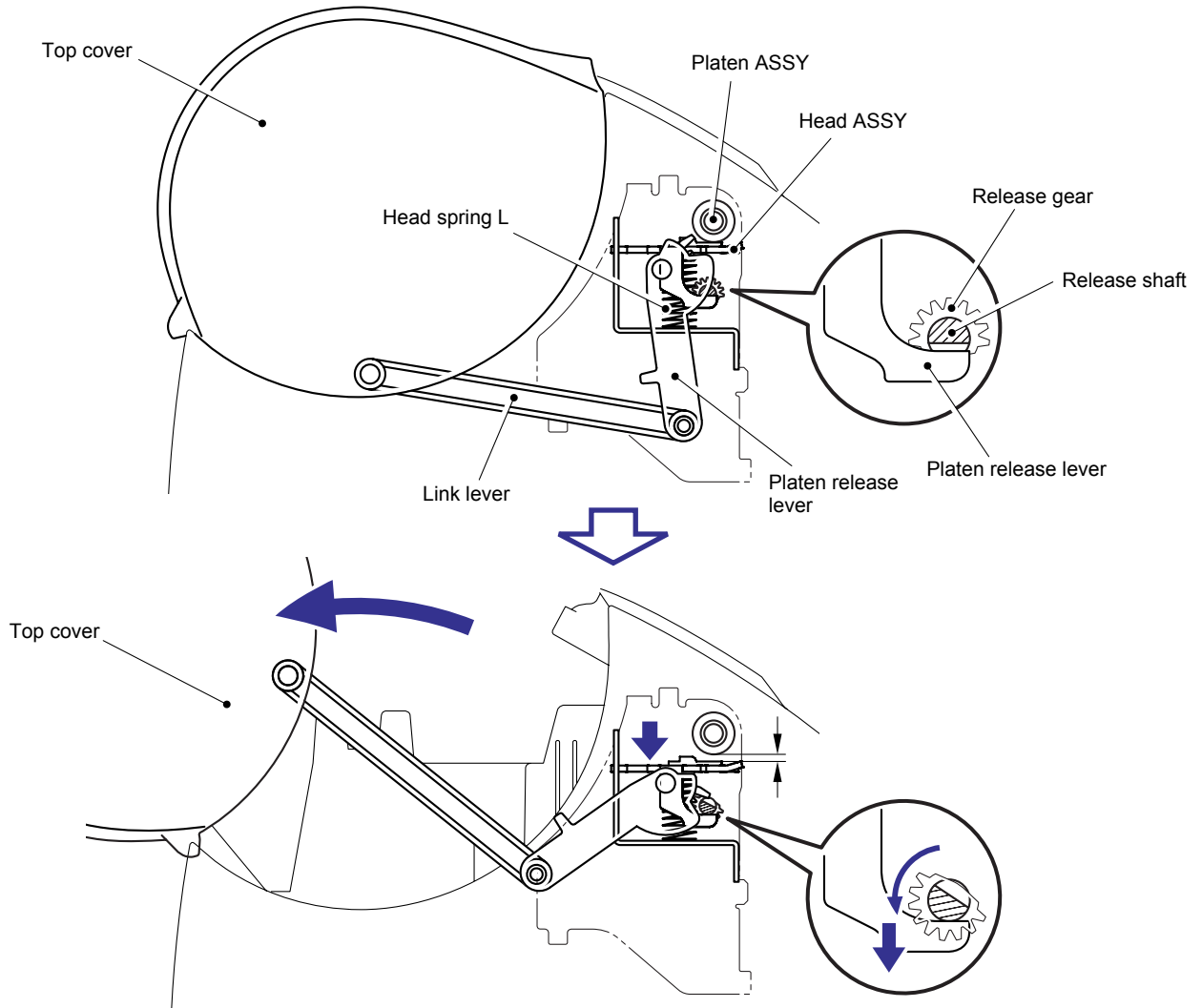
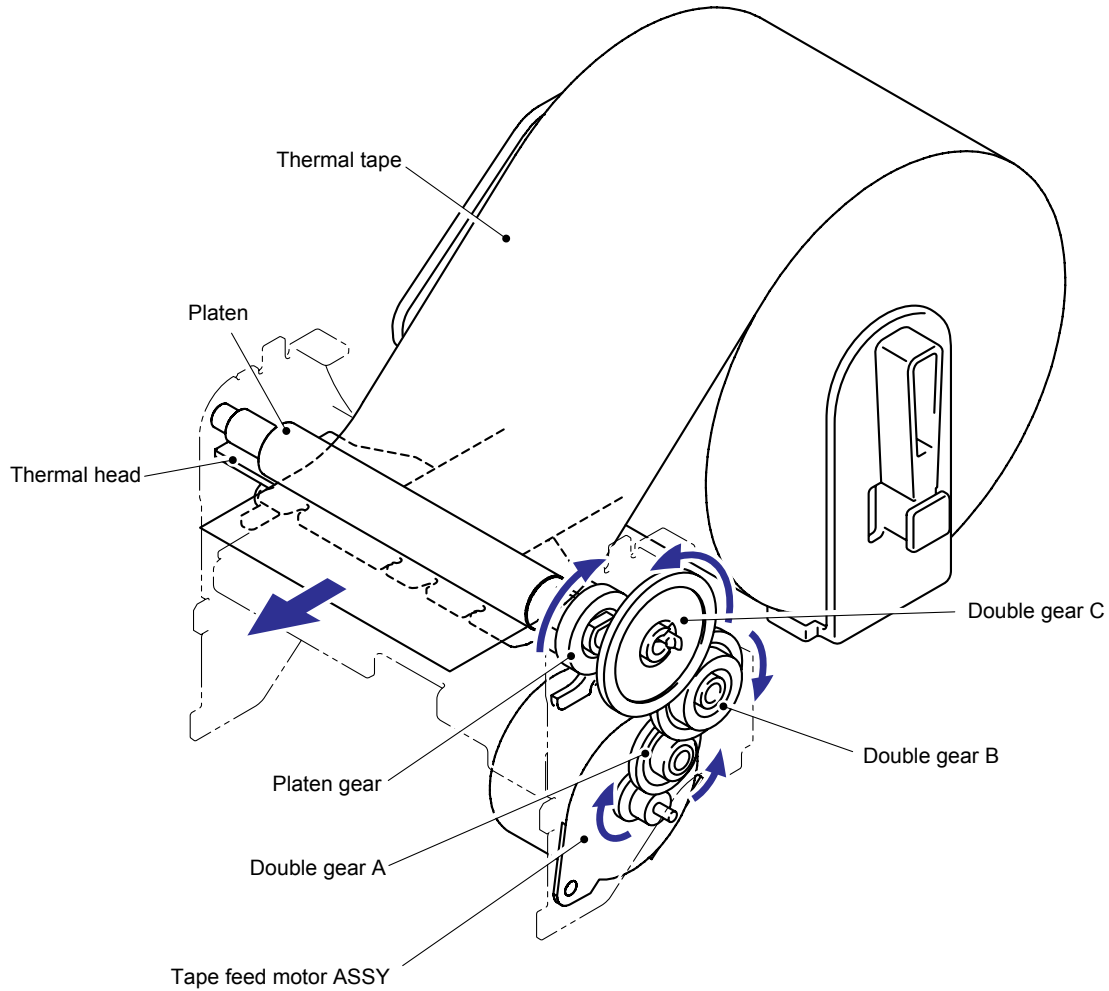

Fig. 2.1-2 Press Contact and Release Mechanism of Thermal Head

### 2.1.3 Tape Feed Mechanism

When the tape is fed, the tape is pressed against the thermal head, which is nipped between the platen and the thermal head. Here, the tape feed motor ASSY (step motor) rotates, of which drive power is transmitted via the gear train to the platen gear and the platen, and consequently the platen can feed the tape.



**Fig. 2.1-3 Tape Feed Mechanism**

## 2.1.4 Automatic Tape Full Cutter Mechanism

The automatic tape full cutter mechanism moves the moving cutter blade up and down to the direction of the fixed cutter blade to cut the tape on the feeding pass. The cam is rotated once so that the moving cutter blade moves up and down and cuts a medium. The cutter motor ASSY rotates from the position where the cutter home position detect sensor is ON, and the gear of the cam is rotated through the cut worm gear. When the cam is rotated once, the cutter motor stops and stays again at the position where the cutter home position detect sensor is ON.

This mechanism provides the mechanism to reverse the driving system, which is used in case that the tape or the like is jammed between the blades. (For the details, refer to “CHAPTER IV TROUBLESHOOTING & ERROR MESSAGE”.)

When the driving system is reversed, the cutter motor stops and stays again at the position where the cutter home position detect sensor is ON.

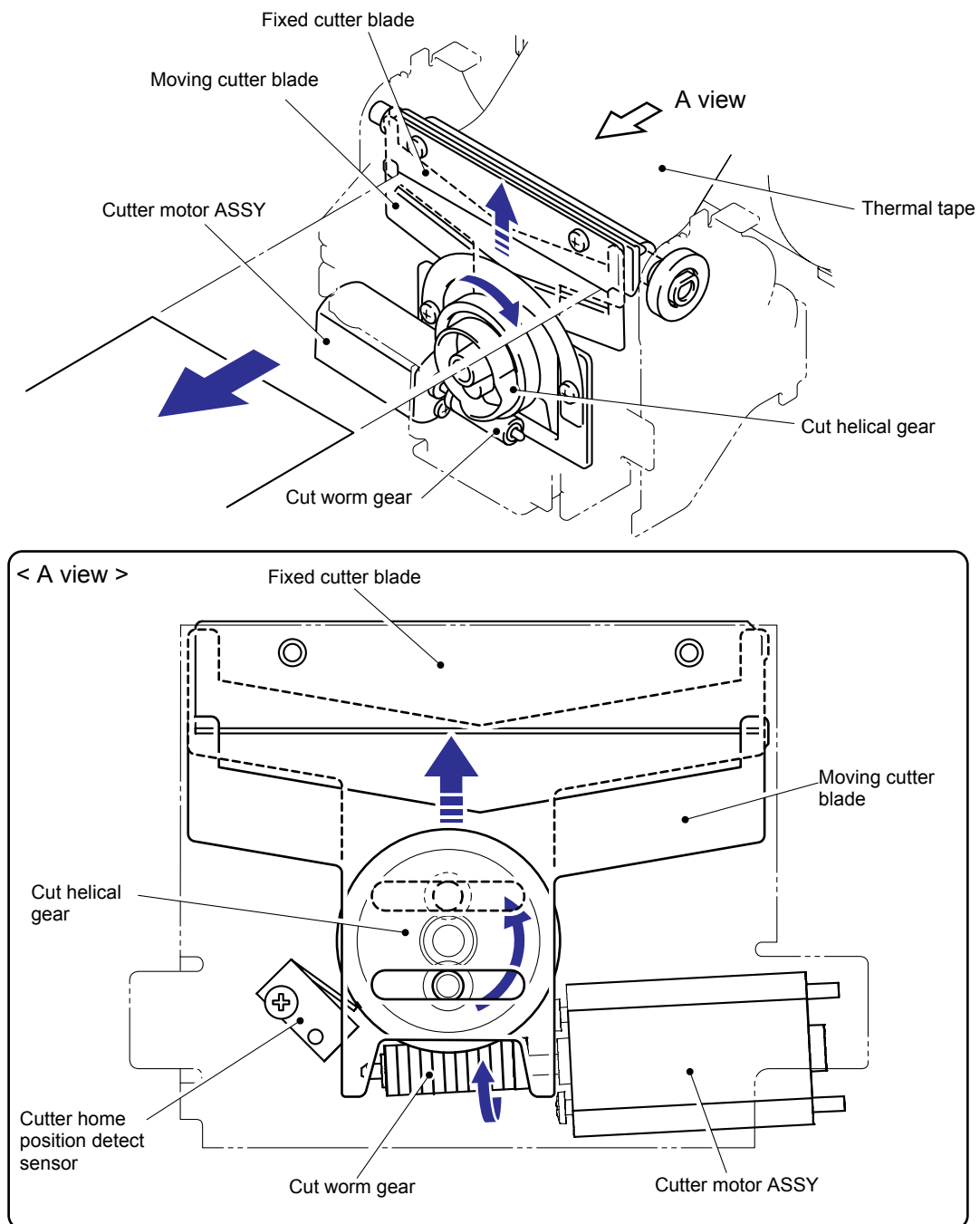

Fig. 2.1-4 Automatic Tape Full Cutter Mechanism

### 2.1.5 Cover Open (Cover Lock) Sensor

The cover open (cover lock) sensor (push switch) is mounted on the SB PCB ASSY. Closing the top cover, the cover sensor arm pushes the cover open (cover lock) sensor (push switch) and the signal of top cover close status is output.

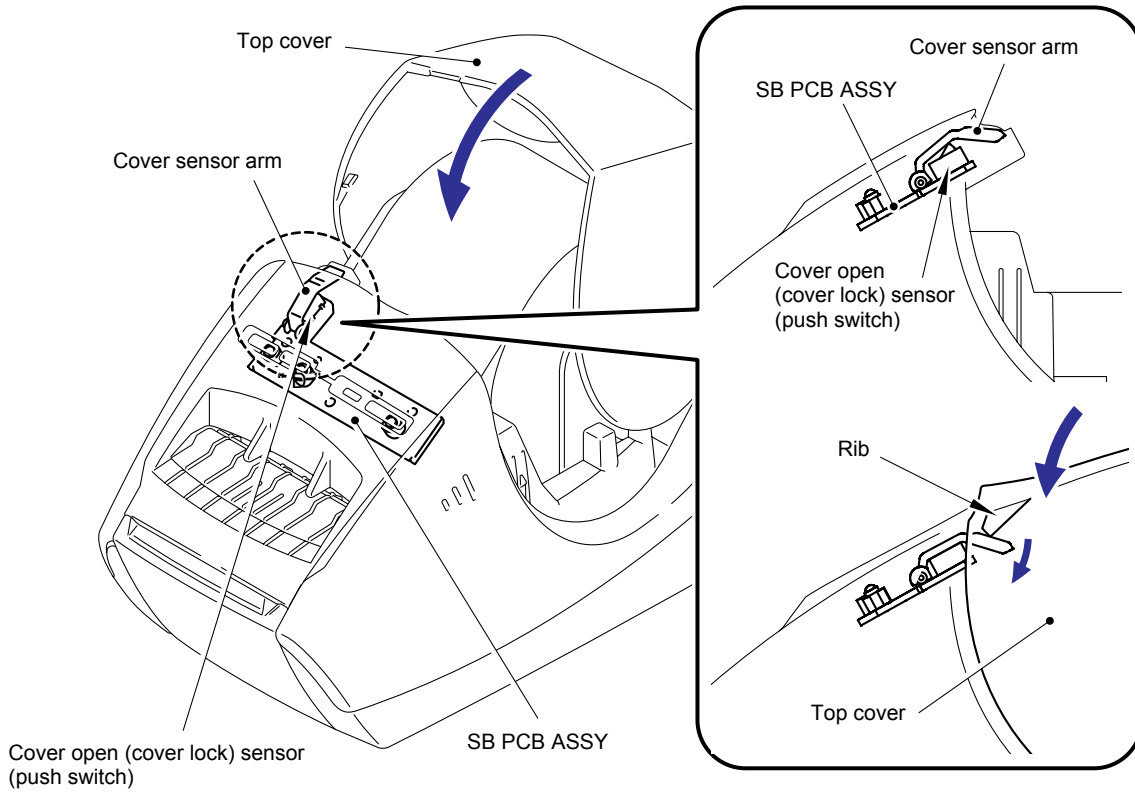
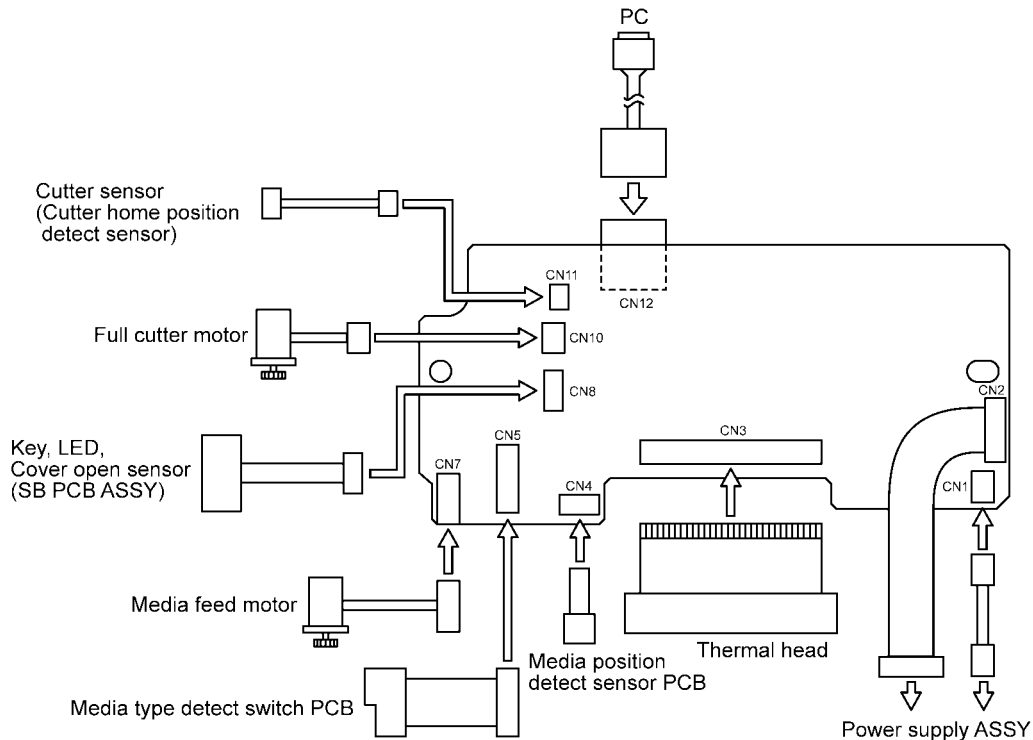

Fig. 2.1-5 Cover Open (Cover Lock) Sensor

## 2.2 OUTLINE OF CONTROL ELECTRONICS

Fig. 2.2-1 shows the block diagram of the control electronics. The control electronics consist of the following components.



**Fig. 2.2-1 Block Diagram of the Control Electronics**

### 2.2.1 Main PCB ASSY

This manages all the components. This PCB consists of CPU, EEPROM, USB chip and motor drivers etc.

### 2.2.2 Media Type Detect Switch PCB (Media PCB ASSY)

The sensor (mechanical SW) that detects media type and size is connected to main PCB ASSY. A semi-fixed resistance (VR) for adjustment of the media position detect sensor is mounted on it.

### 2.2.3 Media Position Detect Sensor PCB (Tape Sensor PCB ASSY)

This sensor detects the printing start position for the die cut label, and checks existence of the zebra pattern media using reflection type photo sensor for the free length label.

#### **2.2.4 Key, LED PCB (SB PCB ASSY)**

This is the PCB equipped with ON/OFF button, Feed button, Cut button, cover open sensor and LED lamp (Green/Red).

#### **2.2.5 Cutter Sensor (Cutter Home Position Detect Sensor)**

This sensor detects existence of the cutter at its home position (micro switch).

#### **2.2.6 Media Feed Motor (Tape Feed Motor ASSY)**

The media feed motor supplies the drive power to feed media. This motor is  $\phi 35$  diameter of step motor of which drive voltage is  $V_H$  (25V).

#### **2.2.7 Full Cutter Motor (Cutter Motor ASSY)**

The cutter motor supplied the drive power to cut media. This motor is a DC motor of which drive voltage is  $V_H$  (25V).

#### **2.2.8 Thermal Head**

Thermal head is thick film and drive built-in type thermal head, which consists of 720 dots by one row/300dpi. The drive voltage is  $V_H$  (25V).



## 2.3 MAIN PCB

Fig. 2.3-1 shows the block diagram of the main PCB. The main PCB consists of the following components.

- (1) CPU (Including ROM and RAM)
- (2) EEPROM (4Kbit)
- (3) Power supply ON/OFF circuit, Feed button ON/OFF circuit, Cut button ON/OFF circuit, LED ON/OFF circuit
- (4) Head power supply ON/OFF circuit
- (5) Full cutter motor driver circuit and Media feed motor driver circuit
- (6) Media type detect sensor circuit, Media position detect sensor circuit and Cover open sensor circuit
- (7) Head temperature detect circuit
- (8) Cutter home position detect sensor circuit
- (9) Reset circuit
- (10) USB interface circuit

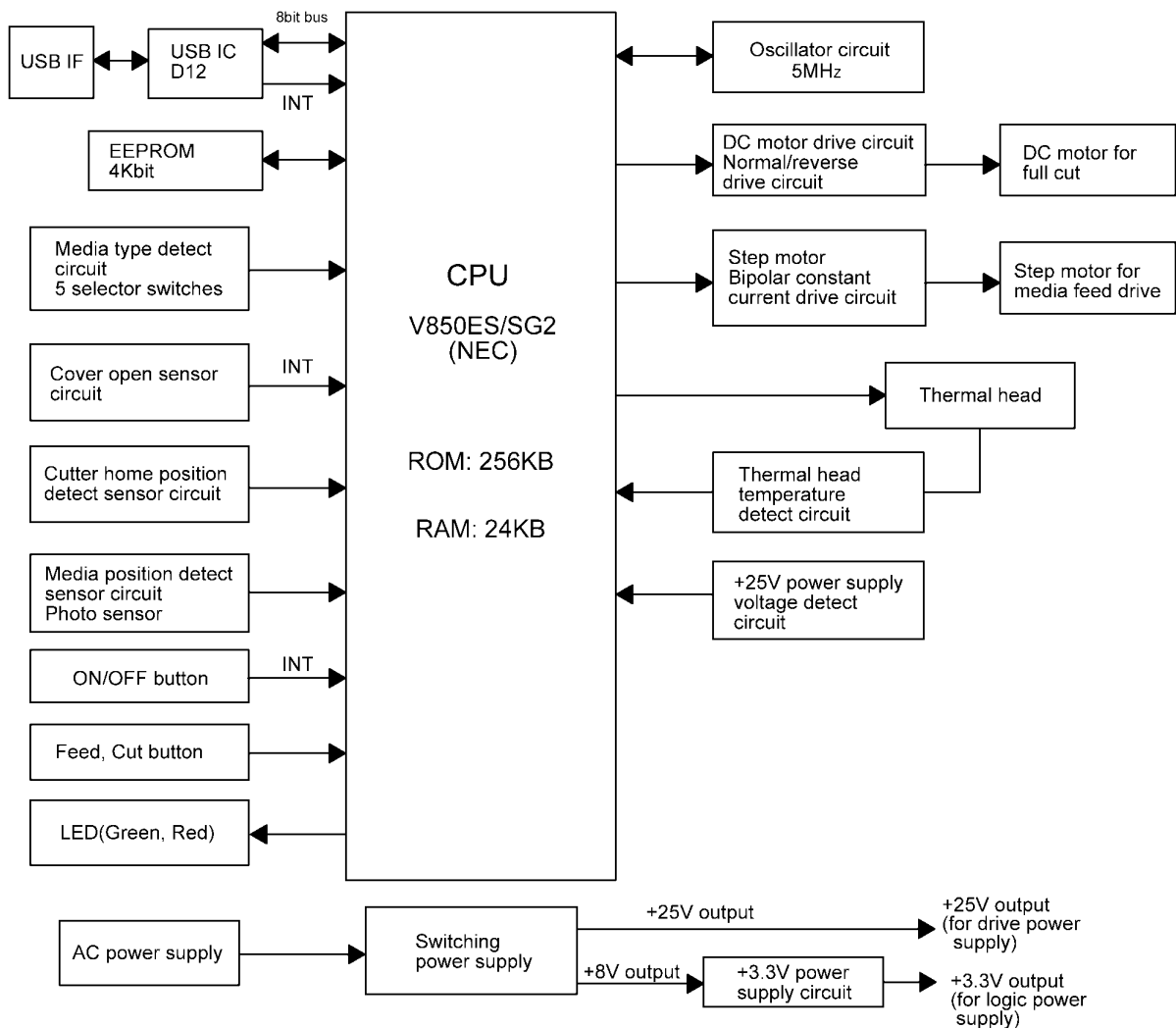

Fig. 2.3-1 Block Diagram of Main PCB

### 2.3.1 Logic Components

[ 1 ] CPU

CPU (U7) controls and manages the entire system, which is 32 bit microcomputer of NEC brand. This CPU contains the 256 Kbyte ROM that stores the control program data. The embedded 24 Kbyte RAM is used mainly for temporary storage of incoming data from PC.

[ 2 ] EEPROM

One 4Kbit EEPROM (U2) is used. This memory is used for write and storage of Vendor ID code, Product ID code and mechanical information. If the main PCB ASSY is replaced, it is needed to write the serial number printed on the EEPROM mounted on the main PCB ASSY and the mechanical configuration data. For this operation, refer to “APPENDIX 1 MAINTENANCE SOFTWARE OPERATION”.

### 2.3.2 Key, LED Circuit

(1) Power supply ON/OFF circuit

This circuit detects the state of ON/OFF of the ON/OFF button. Pressing this button in the power supply OFF state (LED OFF), LOW signal is sent to the CPU. Then the CPU starts initializing process and establishes the status of power supply ON (LED ON and ready for data acceptance from PC). Pressing this button in the condition that the status of power supply is ON and the status of ready for data acceptance from PC (LED ON), the CPU starts power OFF process, turns the LED OFF and changes the status into power supply OFF (LED OFF). Pressing this button in the condition that the status of power supply is ON and now going on printing, the CPU stops printing, starts power OFF process after reading and discarding the data sent from PC, and changes the status into power supply OFF (LED OFF).

(2) Feed button ON/OFF circuit

Pressing this button, this circuit activates the tape feed motor ASSY and it feeds a medium by a certain distance. This motion does not involve printing.

(3) Cut button ON/OFF circuit

Pressing this button, this circuit activates the cutter motor ASSY and it cuts a medium.

(4) LED ON/OFF circuit

This circuit turns the LED on, off and makes it blinking according to the status of power supply ON/OFF and some error conditions. For more details, refer to section “4.3 LED Control in Different Situations and Measure Against Errors”.

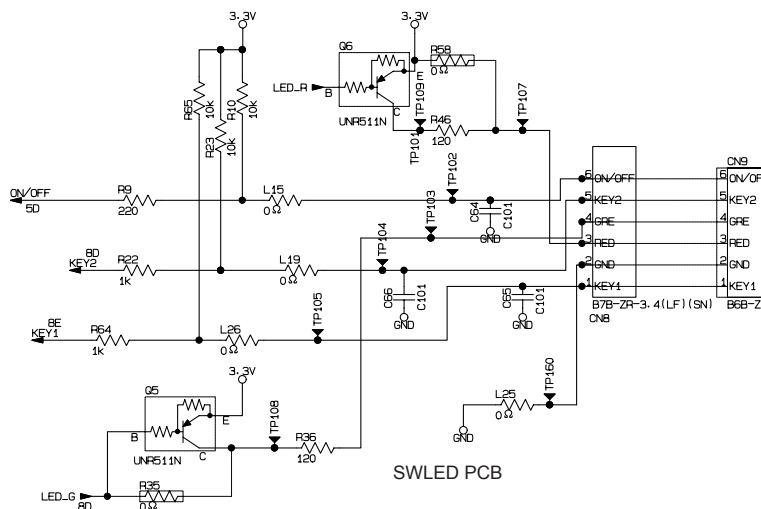

Fig. 2.3-2 Key, LED Circuit

### 2.3.3 Head and Motor Power Supply ON/OFF Circuit

Turning the CPU status of PDL10 (VHON, 81 pin) to High, top cover is closed, and turns cover open sensor Low, Q10 turns on, V<sub>H</sub> (25V power supply) turns on and consequently the head and motor is energized.

In addition, turning on this circuit, “media position detect sensor circuit”, “cutter home position detect circuit” are energized.

Turning the CPU status of PDL10 (VHON, 81 pin) to Low, Q10 turns off, or keeping the top cover open, Q2 turns on, then these condition make V<sub>H</sub> (25V power supply) turns off and consequently the head and motor power supply is cut off.

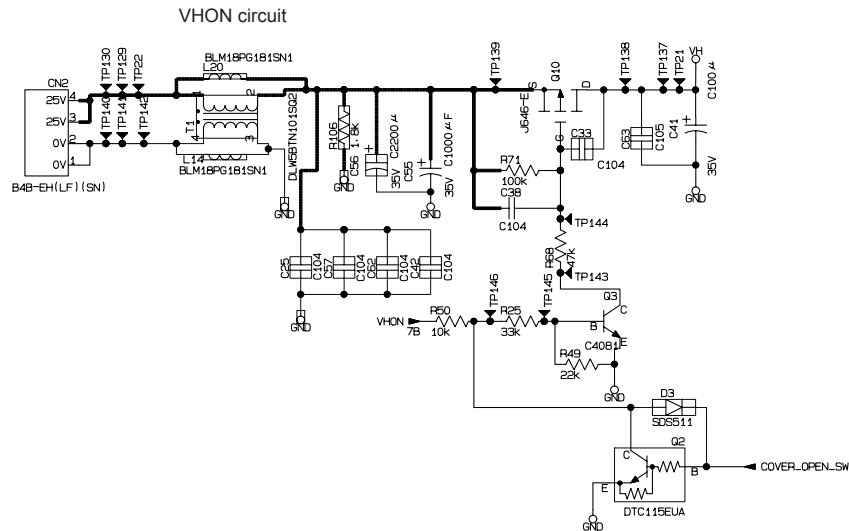

Fig. 2.3-3 Head and Motor Power Supply ON/OFF Circuit

### 2.3.4 Full Cutter Motor Driver Circuit and Media Feed Motor Driver Circuit

(1) Full Cutter motor driver circuit

This circuit drives the DC motor to cut a medium as described in subsection “2.1.4 Automatic Tape Full Cutter Mechanism”. When the CPU receives cut request from the “Cut button ON/OFF circuit (refer to 2.3.2(3))”, it confirms that the top cover ASSY is closed, and turns VHON (81 pin) high. Then the CPU controls C\_DCF (37 pin) and C\_DCR (38 pin) to driver the cutter motor.

(2) Media feed motor driver circuit

When the CPU receives feed request from the “Feed button ON/OFF circuit (refer to 2.3.2(2))”, it confirms that the top cover ASSY is closed, and turns VHON (81 pin) high. Then the CPU controls SIN 1 (44 pin) through SIN 6 (49 pin) to driver the media feed motor.

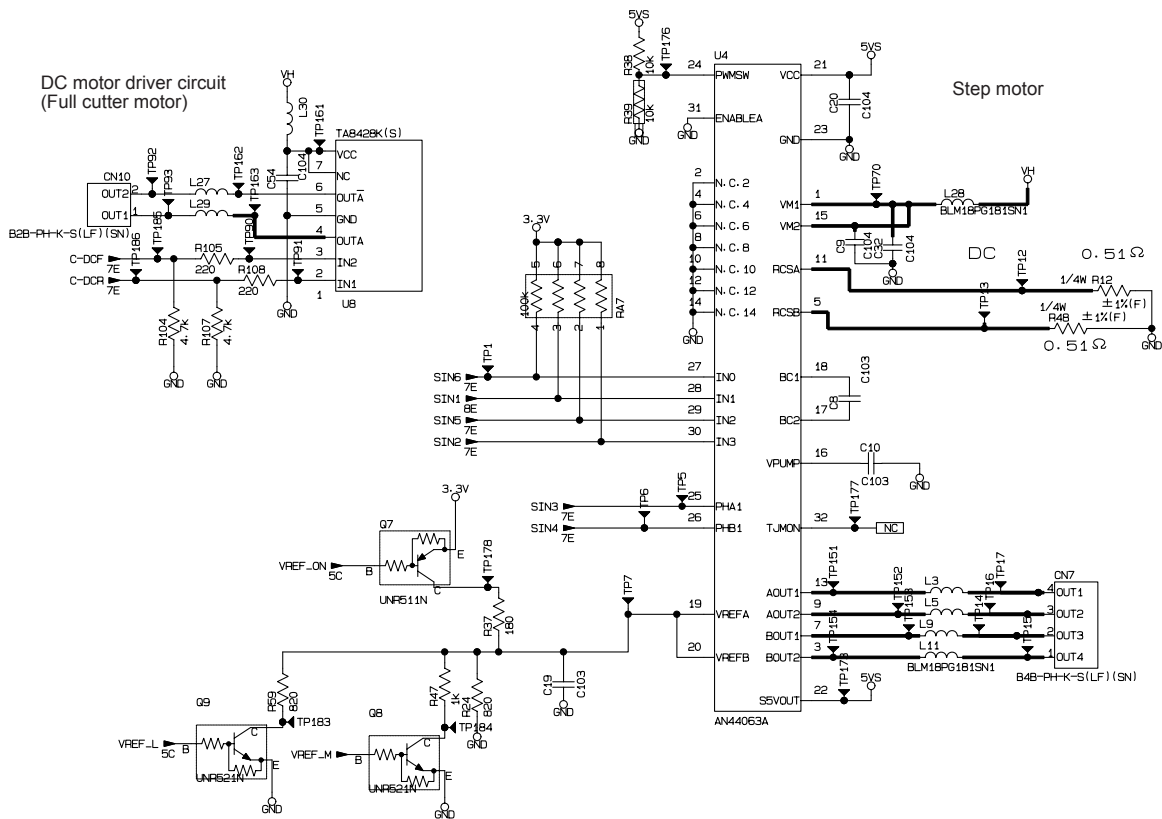

Fig. 2.3-4 Full Cutter Motor Driver Circuit and Media Feed Motor Driver Circuit

### 2.3.5 Media Type Detect Sensor Circuit, Media Position Detect Sensor Circuit and Cover Open Sensor Circuit

(1) Media type detect sensor circuit

The sensor circuit consists of media sensor with five switch systems (CAS1 through CAS5). Loading a tape cassette, some of five switches turn on and the others retain off according to the configuration of its' ID code apertures. Clogged ID apertures turn on the corresponding sensor switches.

As shown Table 3.1-1, the CPU identifies media type and size from the status of each sensor switch.

Fig.2.3-5 shows the media type detect sensor circuit.

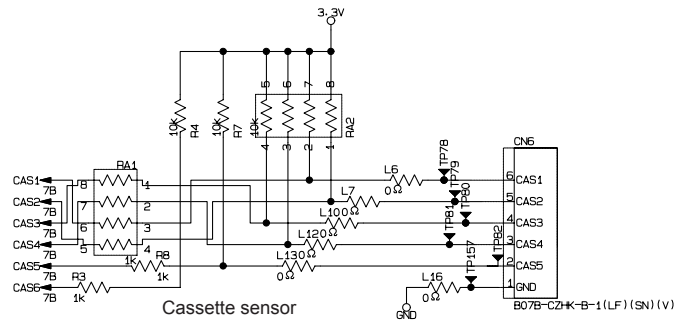
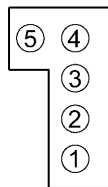

Fig. 2.3-5 Media Type Detect Sensor Circuit

Media type	SW1	SW2	SW3	SW4	SW5
No media (not loaded)	0	0	0	0	0
Standard Address	1	0	0	0	0
Large Address	0	1	0	0	0
Small Address	1	1	0	0	0
Sipping	0	0	1	0	0
Multi purpose	1	0	1	0	0
File Folder	0	1	1	0	0
CD/DVD	1	1	1	0	0
Square Paper	0	0	1	1	0
Round Paper 12	1	0	0	0	1
Round Paper 24	0	1	0	0	1
Continuous Length Paper 12	0	1	0	1	1
Continuous Length Paper 29	0	0	1	0	1
Continuous Length Paper 62	1	0	1	0	1
Continuous Length Paper 62 White Removable					
Continuous Length Paper 62 Yellow Removable					
Continuous Length Film White 29	0	1	1	0	1
Continuous Length Film White 62	1	1	1	0	1
Continuous Length Film Yellow 62	0	0	0	1	1
Continuous Length Film Clear 62	1	0	0	1	1
Not to be used	1	1	1	1	1

<Layout of Sensors (overhead view)>



Identifies from the status of five switches mounted on the machine.

0: Sensor OFF

1: Sensor ON

(2) Media position detect sensor circuit

When performing printing and FEED motion through the process described in subsection “2.3.4 (2) Media feed motor driver circuit”, the CPU reads the sensor value to detect the medium position. The CPU receives the voltage of the media position detect sensor (reflective photo sensor) sent through CN4 and input it through SENTAN (100 pin). The CPU processes this voltage through AD conversion and inspects the print mark on the back face of medium that stays on the sensor position. A semi-fixed resistance (VR) for adjustment of the media position detect sensor is mounted on the media type detect switch PCB.

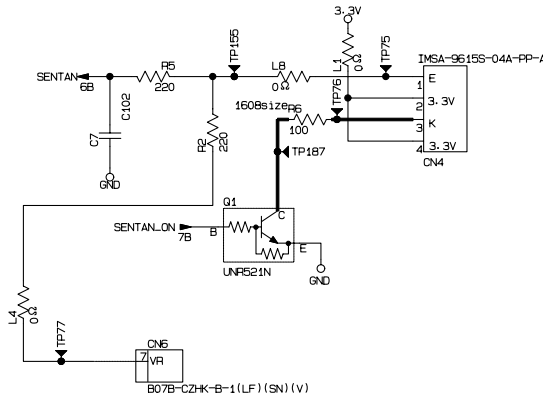

Fig. 2.3-6 Media Position Detect Sensor Circuit

(3) Cover open sensor circuit

It identifies open/close of the top cover from the status of mechanical switch. Opening the top cover, the contact of cover open sensor on SB PCB ASSY opens, and then the signal is sent through CN8 to COVER\_OPEN\_SW (19 pin) of the CPU. The CPU detects open/close of the cover from the change of voltage at 19 pin. The CPU stops all performances if detecting cover open during printing, FEED or CUT.

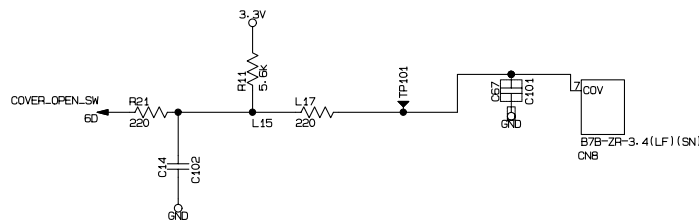

Fig. 2.3-7 Cover Open Sensor Circuit

### 2.3.6 Head Temperature Detect Circuit

This circuit measures the temperature described below.

Head temperature: The CPU determines the ambient temperature of the head from the AD converted voltage value input to TH (98 pin) of the CPU via CN3.

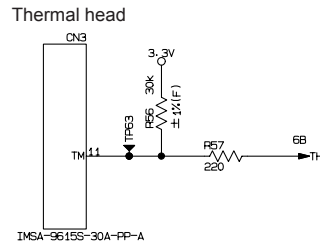

Fig. 2.3-8 Head Temperature Detect Circuit

### 2.3.7 Cutter Home Position Detect Sensor Circuit

Confirm that the cutter stays on its' home position prior to printing.

When the cutter returns to the home position, the cutter home position detect sensor circuit recognizes it and stops the DC motor driving.

The sensor uses a micro switch to detect the position of the cutter.

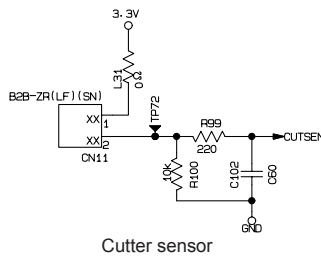

Fig. 2.3-9 Cutter Home Position Detect Sensor Circuit



### 2.3.8 Reset Circuit

When power is supplied from the power supply PCB, +3.3V is supplied, and power is supplied to the CPU. At this point, if +3.3V voltage line goes over +2.8V, the reset circuit (U5) sets High to the RESET input (14 pins) of the CPU, clearing the RESET status of the CPU. If the +3.3V voltage line drop to +2.8V or lower due to any reason during operation, the reset circuit returns Low signal to the CPU and the CPU goes to the RESET status.

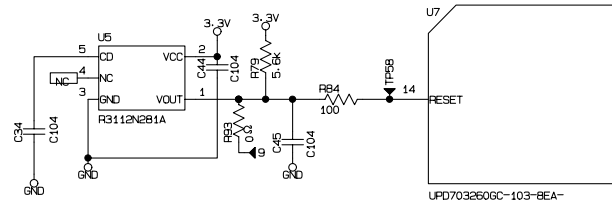

Fig. 2.3-10 Reset Circuit

### 2.3.9 USB Interface Circuit

The CPU of QL-570 is connected with a PC using the USB cable via U6 and CN12. U6 and CPU (U7) establishes bus connection with 8-bits.

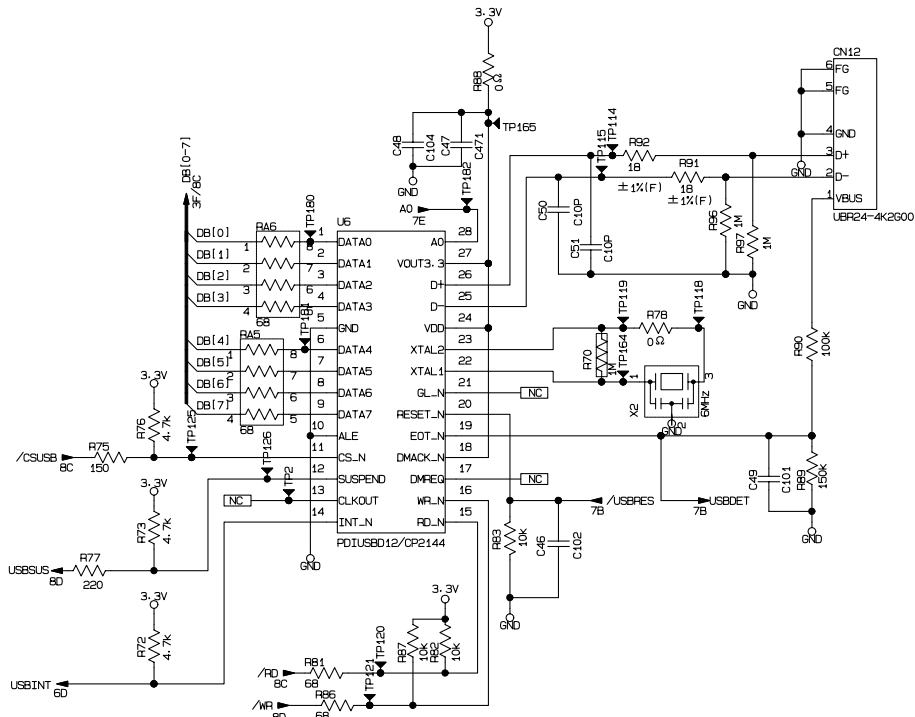

Fig. 2.3-11 USB Interface Circuit

## **CHAPTER III DISASSEMBLY AND REASSEMBLY**

### **3.1 SAFETY PRECAUTIONS**

- (1) The disassembly or reassembly work should be carried on a grounded antistatic sheet. Otherwise, the LSIs and electronic parts may be damaged due to the electricity charged in your body.
- (2) When transporting PCBs, be sure to wrap them in conductive sheets such as aluminum foil.
- (3) When using soldering irons and other heat-generating tools, take care not to damage the resin parts such as wires, PCBs, and covers.
- (4) Be careful not to lose small parts such as screws, washers, or other parts removed for parts replacement.
- (5) Tighten screws according to the tightening torque lists.
- (6) Lubricate according to the lubrication points list.

### 3.2 TIGHTNING TORQUE LISTS

Location	Screw type	Q'ty	Tightening torque N•cm
Lower plate ASSY	Taptite, bind B M2.6x6	4	0.343 ± 0.049
Power supply ASSY	Taptite, bind B M2.6x6	2	0.343 ± 0.049
Ground spring plate	Taptite, bind B M2.6x6	1	0.343 ± 0.049
FG harness ASSY	Taptite, bind B M2.6x6	1	0.343 ± 0.049
Main PCB ASSY	Taptite, bind B M2.6x6	1	0.343 ± 0.049
Media PCB ASSY	Taptite, bind B M2.6x6	1	0.343 ± 0.049
Side cove L	Taptite, bind B M2.6x8	2	0.343 ± 0.049
Side cove R	Taptite, bind B M2.6x8	2	0.343 ± 0.049
Panel cover	Taptite, bind B M2.6x8	2	0.343 ± 0.049
SB PCB ASSY	Taptite, bind B M2.6x6	3	0.343 ± 0.049
Upper cover	Screw, bind M2.6x4	2	0.392 ± 0.098
	Taptite, bind B M2.6x6	3	0.343 ± 0.049
Insert guide	Taptite, bind B M2.6x8	2	0.245 ± 0.049
Mecha ASSY	Taptite, bind B M2.6x6	2	0.343 ± 0.049
Cutter unit ASSY	Screw, bind M2.6x5	2	0.392 ± 0.098
Platen shaft bush	Screw, bind M2X4	1	0.098 ± 0.049
FG harness ASSY	Screw, bind M3x4	1	0.588 ± 0.098
Tape feed motor ASSY	Screw, bind M3x4	1	0.588 ± 0.098

3.3 LUBRICATION POINTS LIST

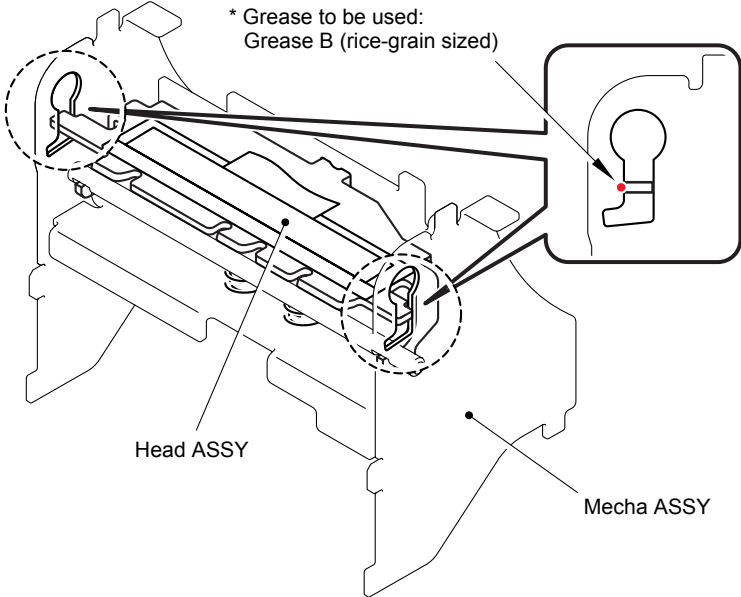
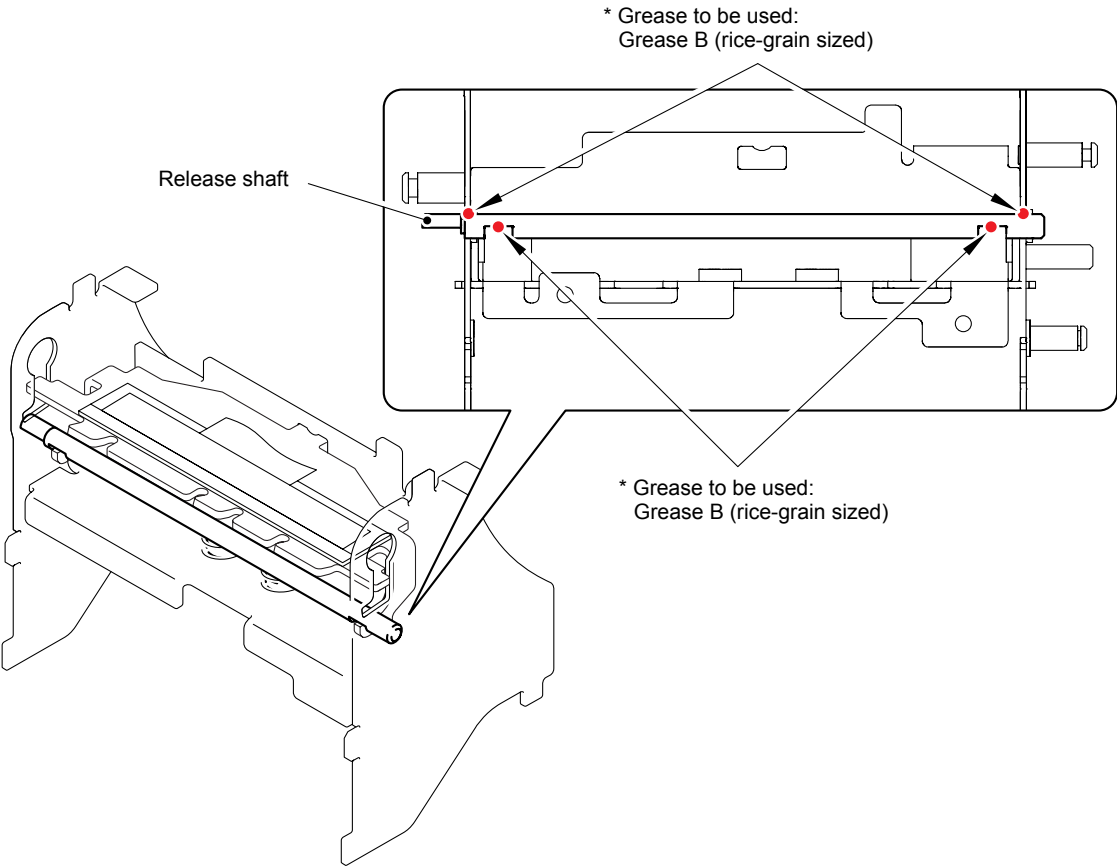

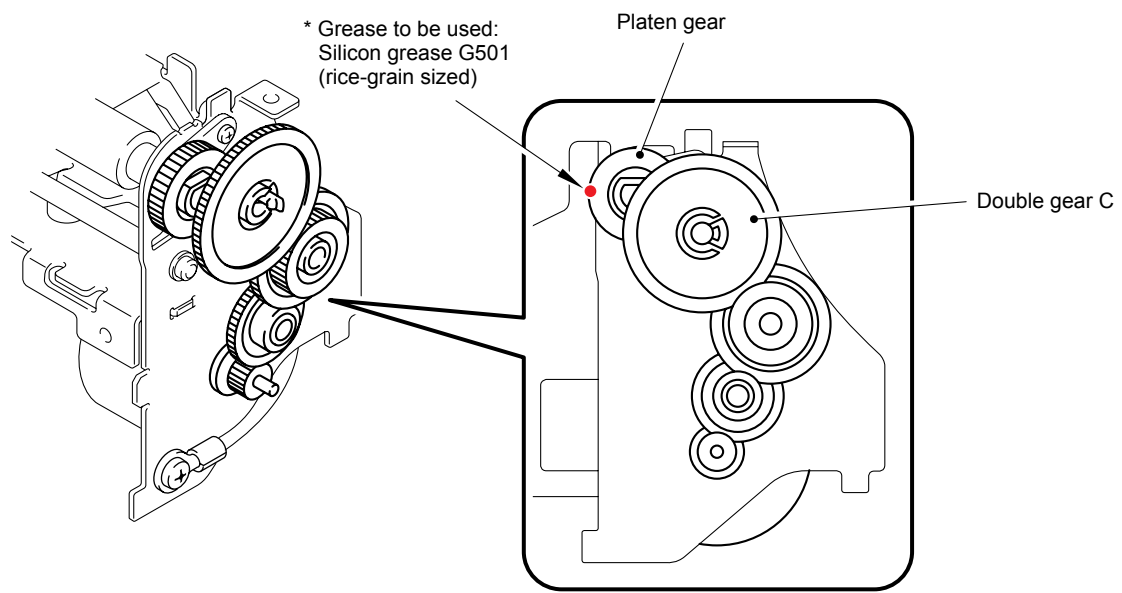

### 3.4 DISASSEMBLY PROCEDURE

#### [ 1 ] Removing the Top Cover and Thermal Tape

*Note: Turn on the power supply with top cover closed, initialize the machine before disassembly.*

- (1) Turn off the power supply and remove the AC cord.

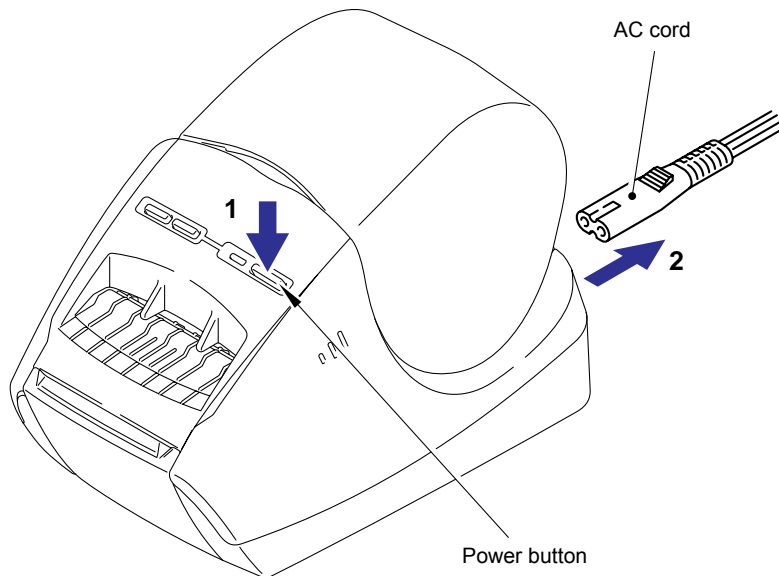

**Fig.3.1-1 Removing the Top Cover and Thermal Tape (1)**

- (2) Open the top cover.
- (3) Remove the thermal tape from the machine.

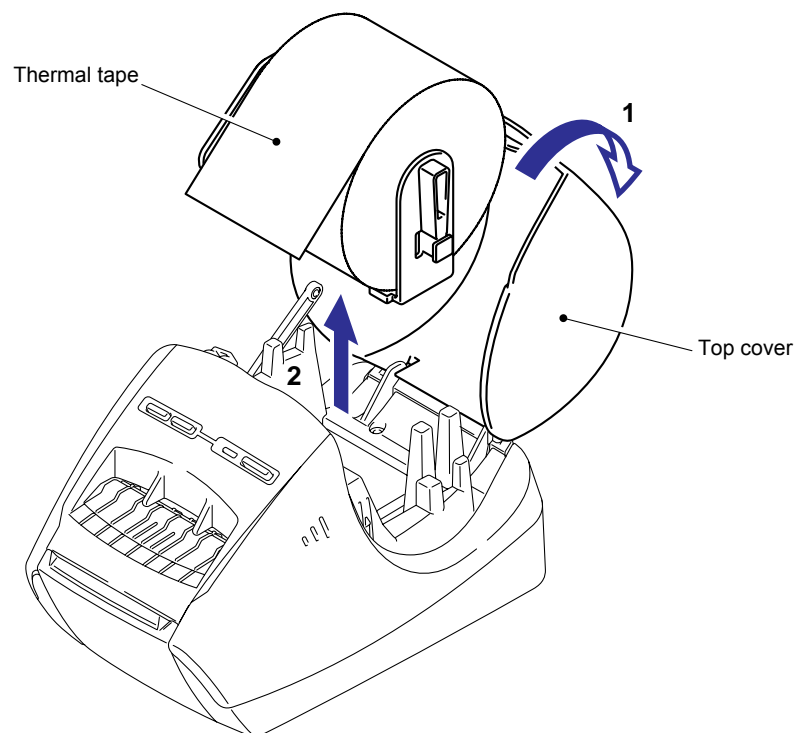

**Fig.3.1-2 Removing the Top Cover and Thermal Tape (2)**

(4) Remove the link lever from the top cover.

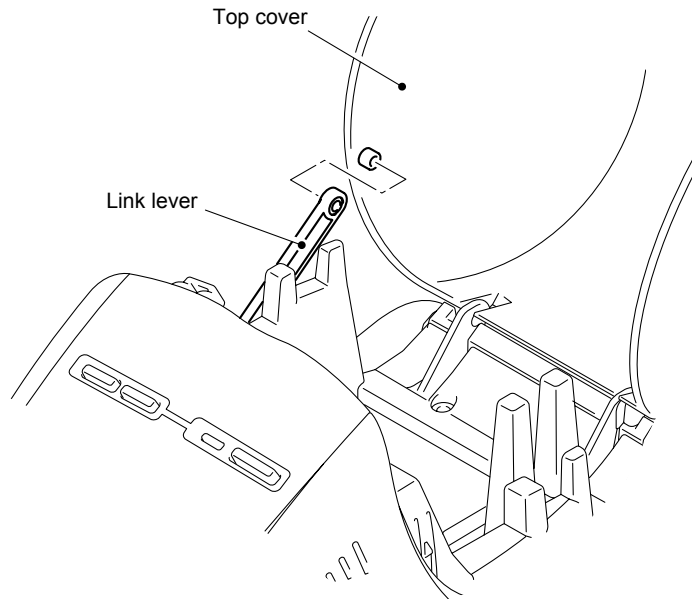

**Fig.3.1-3 Removing the Top Cover and Thermal Tape (3)**

(5) Push the ribs of the upper cover inward, and remove the top cover.

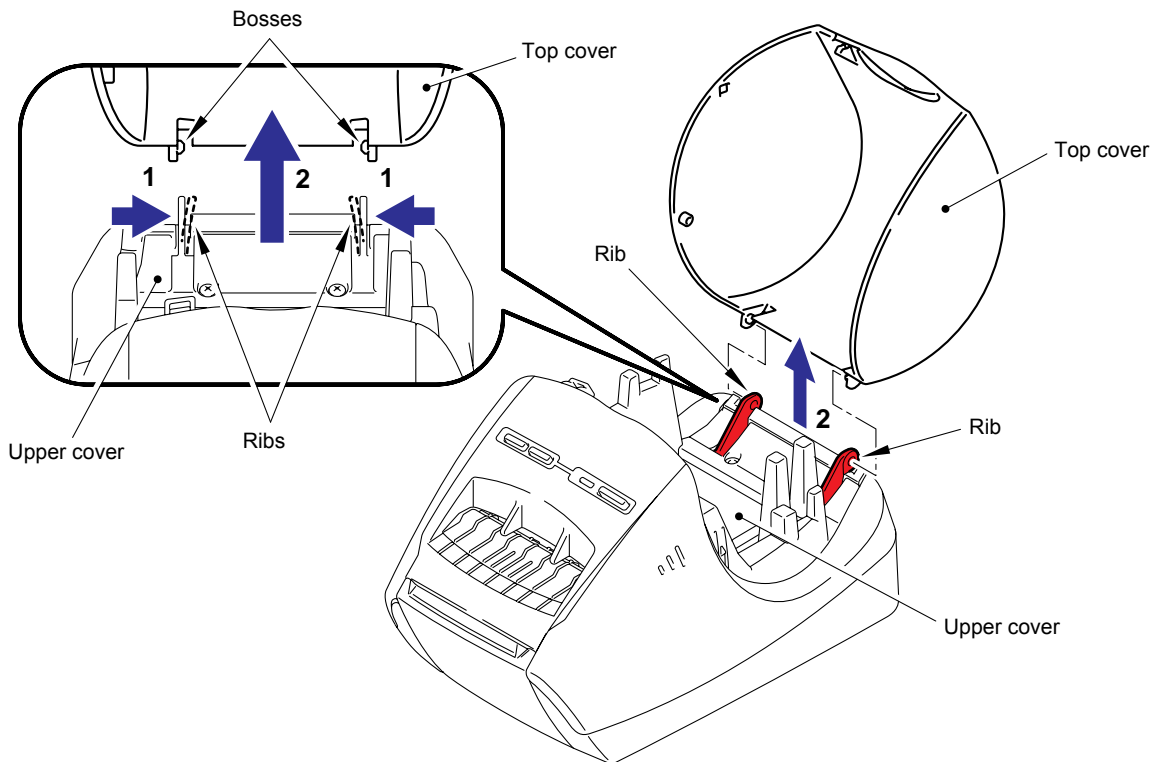

**Fig.3.1-4 Removing the Top Cover and Thermal Tape (4)**

**[ 2 ] Removing the Front Cover and Tray S**

- (1) Open the front cover.
- (2) Push the ribs of the front cover inward, and remove it from the main body.

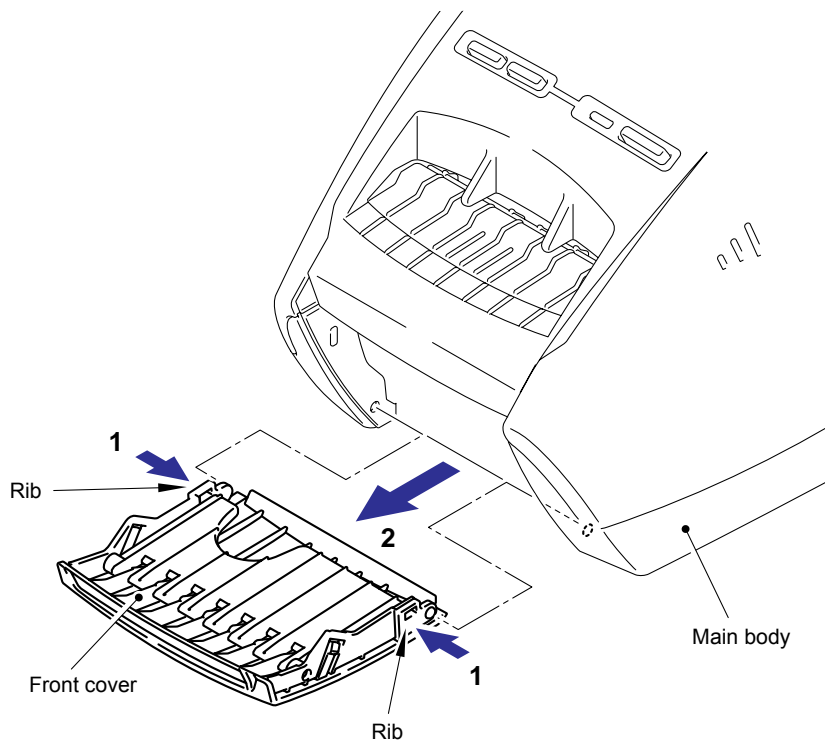

**Fig.3.1-5 Removing the Front Cover and Tray S (1)**

- (3) Bend the tray S and remove it from the front cover.

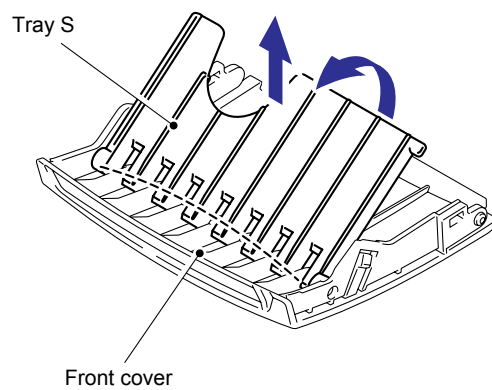
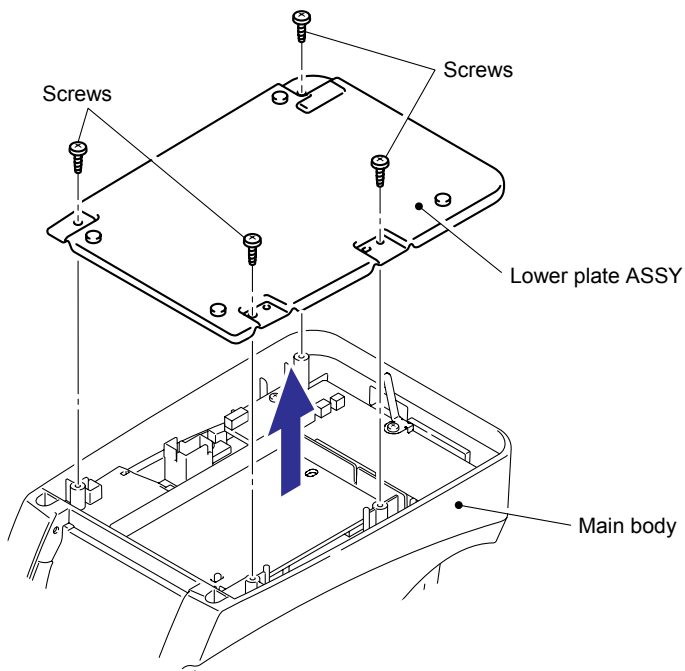

**Fig.3.1-6 Removing the Front Cover and Tray S (2)**



**[ 3 ] Removing the Power Supply ASSY and Main PCB ASSY**

- (1) Turn the main body upside down.
- (2) Remove the four screws, and then remove the lower plate ASSY.



**Fig.3.1-7 Removing the Power Supply ASSY and Main PCB ASSY (1)**

- (3) Remove the two screws, and then remove the power supply ASSY.

*Note: At this point, the harness is still attached, and therefore the power supply ASSY cannot be removed yet.*

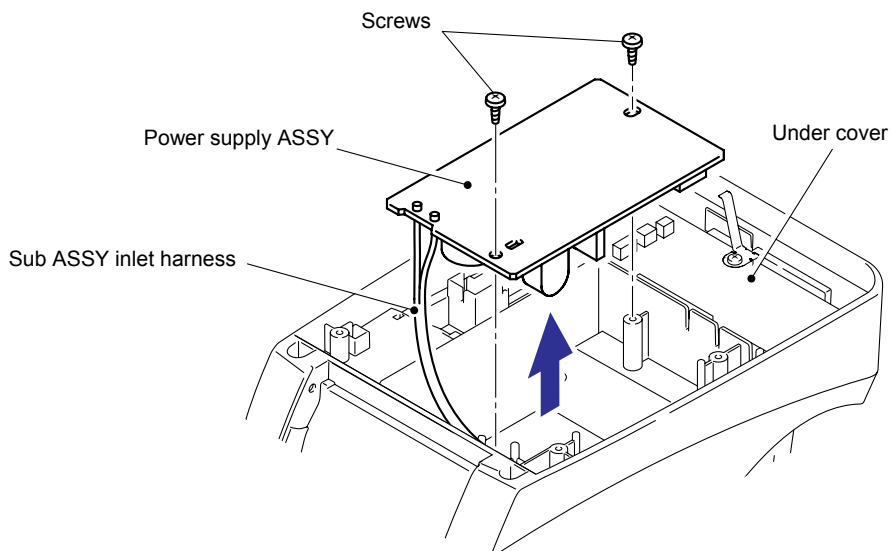

**Fig.3.1-8 Removing the Power Supply ASSY and Main PCB ASSY (2)**

- (4) Remove the main PCB harness from the power supply ASSY.
- (5) Remove the power8 harness ASSY from the main PCB ASSY.

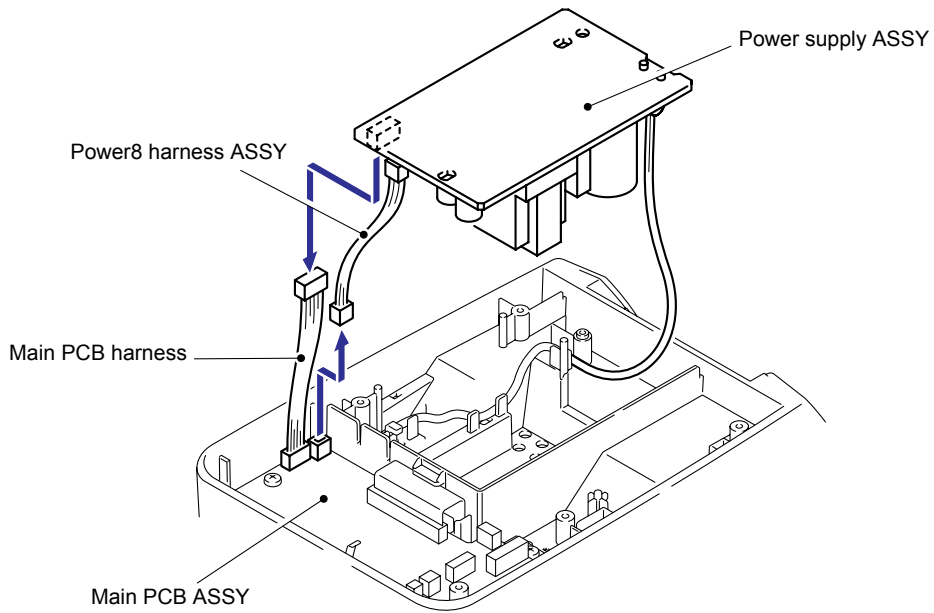

**Fig.3.1-9 Removing the Power Supply ASSY and Main PCB ASSY (3)**

- (6) Remove the power8 harness ASSY from the power supply ASSY.

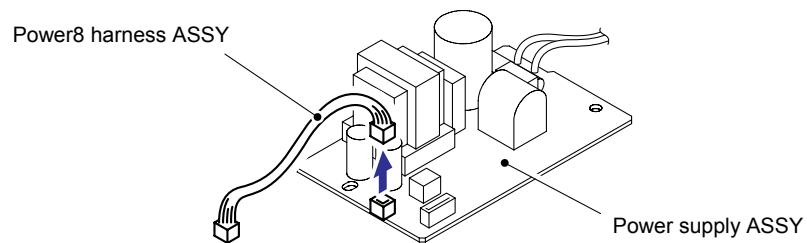

**Fig.3.1-10 Removing the Power Supply ASSY and Main PCB ASSY (4)**

- (7) Remove the filament tape which secures the harness of CN11.

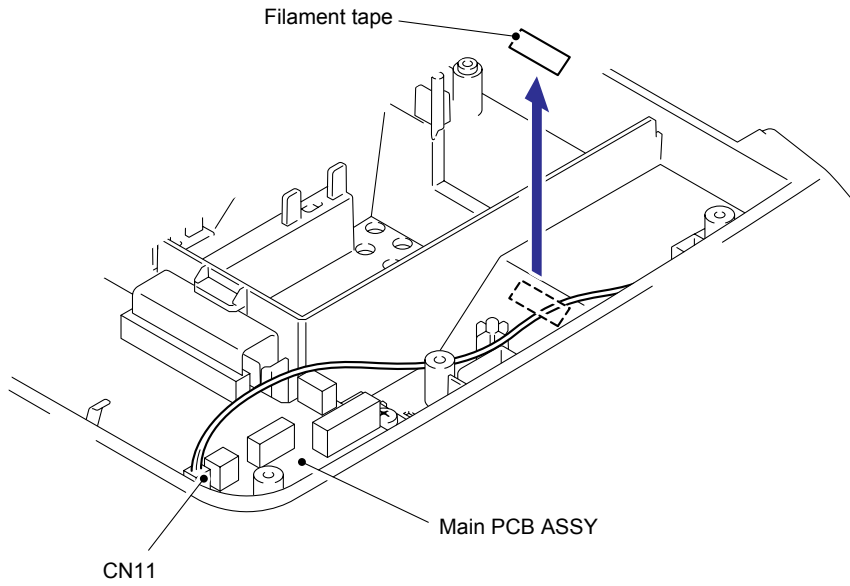

**Fig.3.1-11 Removing the Power Supply ASSY and Main PCB ASSY (5)**

- (8) Remove the five connectors (CN5, CN7, CN8, CN10, CN11) and two flat cables (CN3, CN4) from the main PCB ASSY.

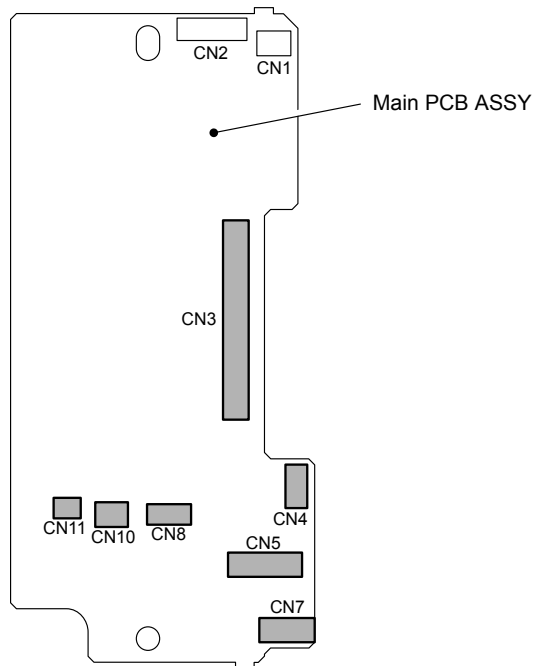

**Fig.3.1-12 Removing the Power Supply ASSY and Main PCB ASSY (6)**

- (9) Remove the three screws, and then remove the ground spring plate, FG harness ASSY and main PCB ASSY.

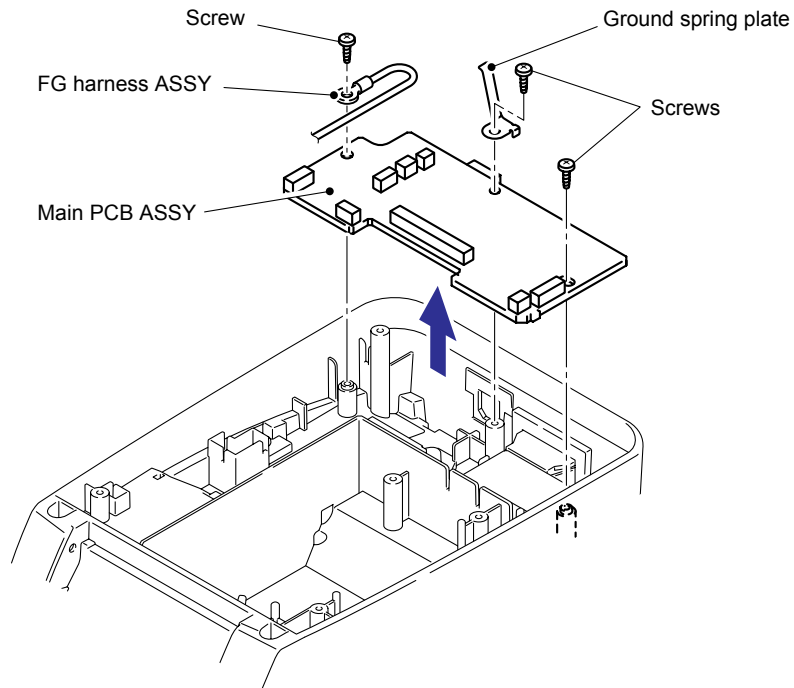

**Fig.3.1-13 Removing the Power Supply ASSY and Main PCB ASSY (7)**

- (10) Remove the insulating sheet S from the under cover.

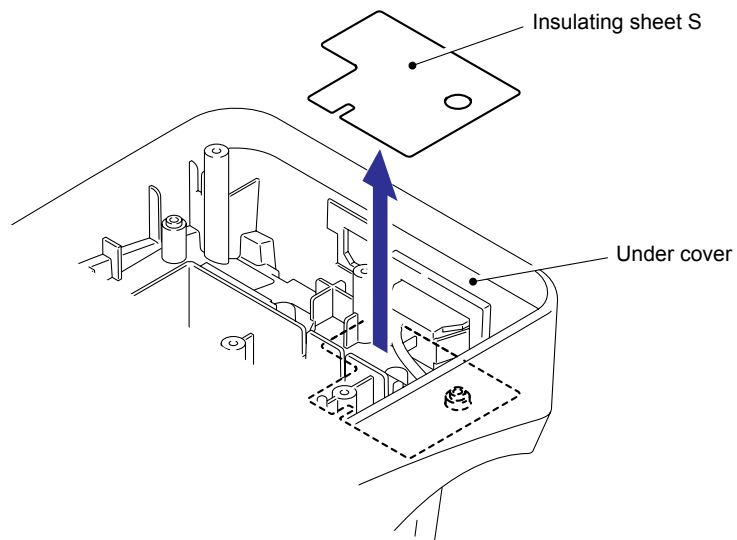

**Fig.3.1-14 Removing the Power Supply ASSY and Main PCB ASSY (8)**

**[ 4 ] Removing the Sub ASSY Inlet**

- (1) Remove the solder of the sub ASSY inlet from the power supply ASSY.

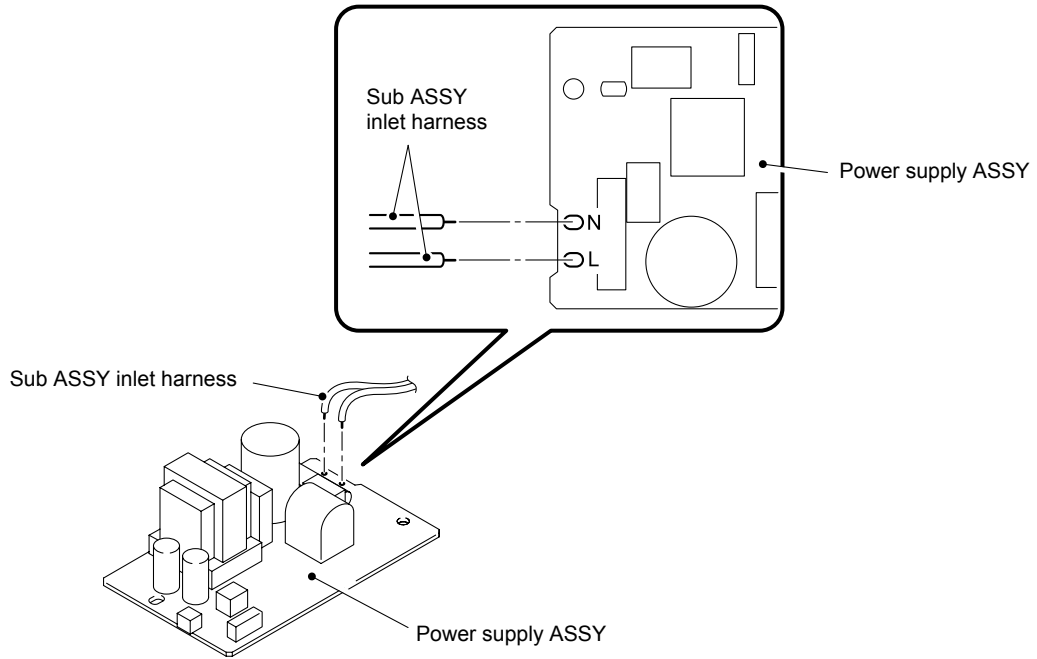

**Fig.3.1-15 Removing the Removing the Sub ASSY Inlet (1)**

- (2) Release the hooks on both sides of the sub ASSY inlet and pull the inlet to the direction of the arrow as shown in the figure below to remove it.

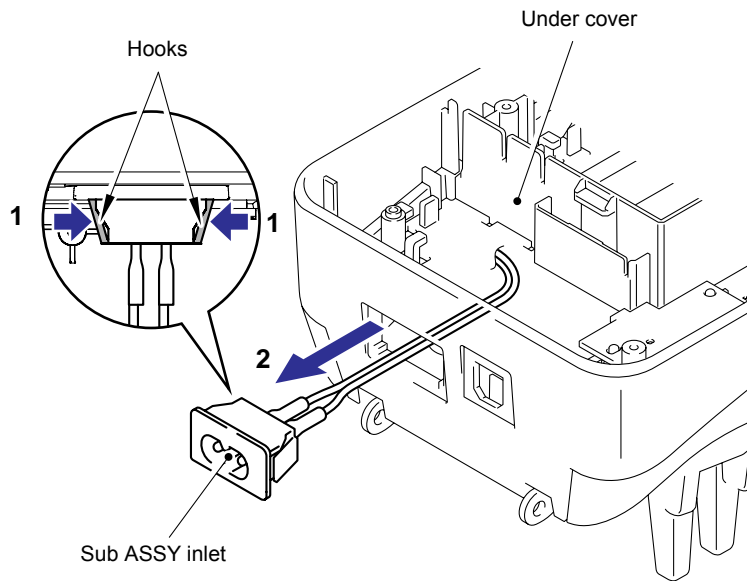

**Fig.3.1-16 Removing the Removing the Sub ASSY Inlet (2)**

**[ 5 ] Removing the Media PCB ASSY**

- (1) Remove the two screws, and then remove the media PCB ASSY from the under cover.

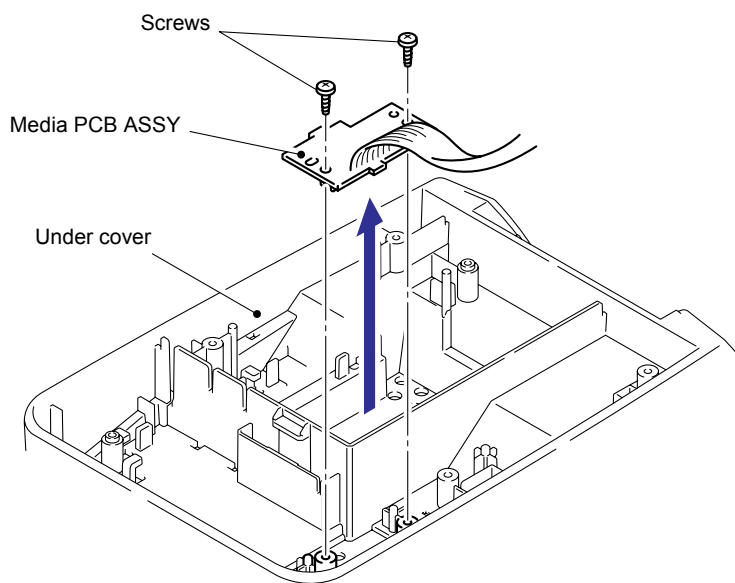

**Fig.3.1-17 Removing the Media PCB ASSY**

**[ 6 ] Removing the Side Cover L, R**

- (1) Turn the main body upside down, and remove the two screws from the under cover.

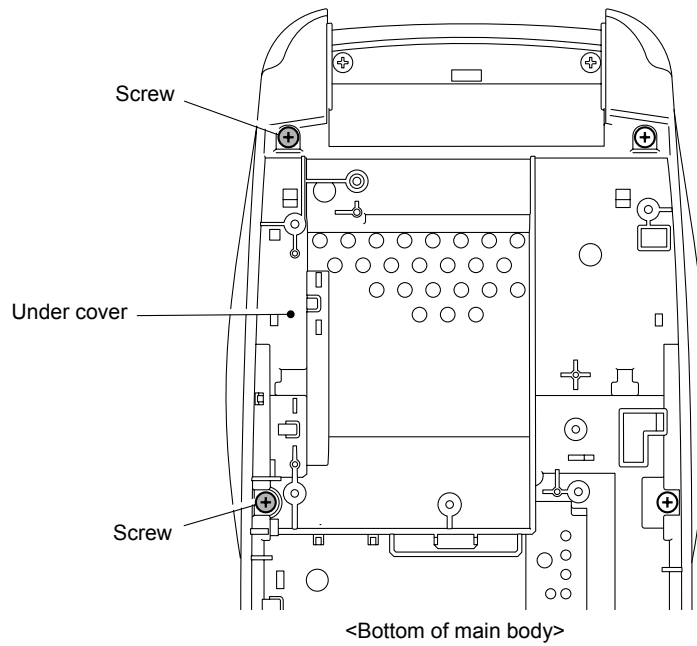

**Fig.3.1-18 Removing the Side Cover L, R (1)**

- (2) Detach the Portion A of the side cover L by hooking your nail on it, and then slightly lift the rear side of the side cover L from the main body.

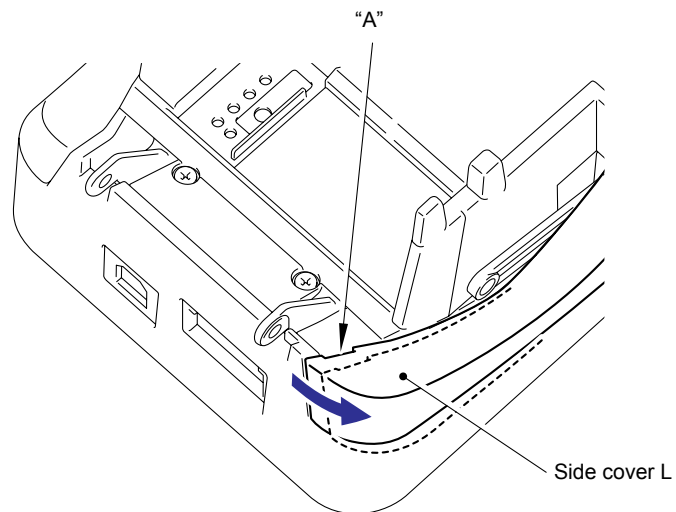

**Fig.3.1-19 Removing the Side Cover L, R (2)**

- (3) Remove the three hooks on the lower side of the side cover L, and then remove the side cover L in the arrow direction.

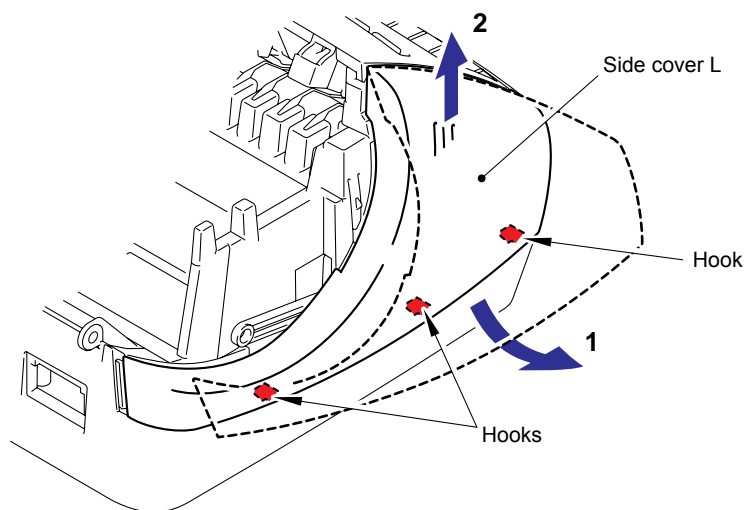

**Fig.3.1-20 Removing the Side Cover L, R (3)**

- (4) Remove the two screws from the under cover.

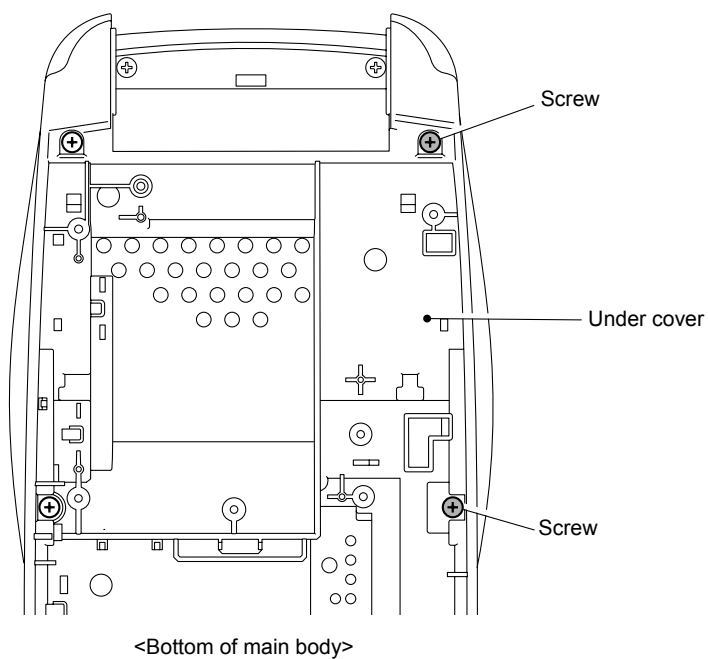

**Fig.3.1-21 Removing the Side Cover L, R (4)**



- (5) Detach the Portion A of the side cover R by hooking your nail on it, and then slightly lift the rear side of the side cover R from the main body.

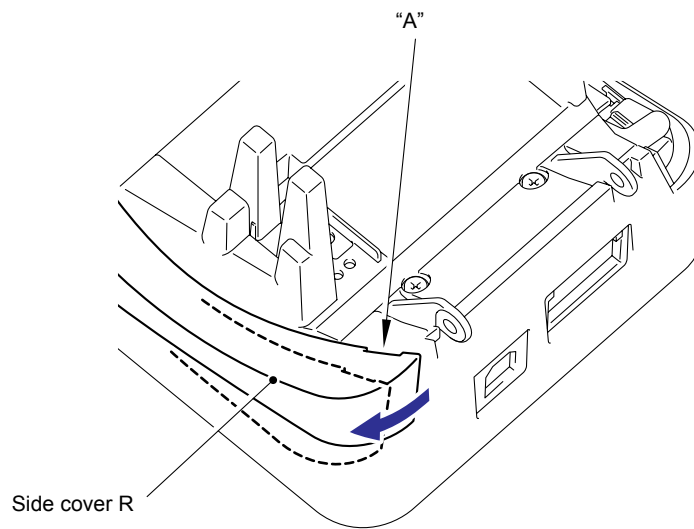

**Fig.3.1-22 Removing the Side Cover L, R (5)**

- (6) Remove the three hooks on the lower side of the side cover R, and then remove the side cover R in the arrow direction.

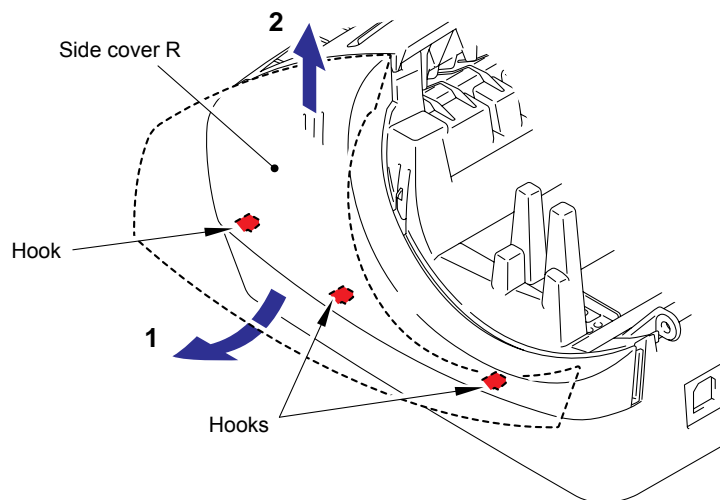

**Fig.3.1-23 Removing the Side Cover L, R (6)**

[ 7 ] Removing the Panel Cover

- (1) Remove the two screws, and then remove the panel cover from the upper cover.

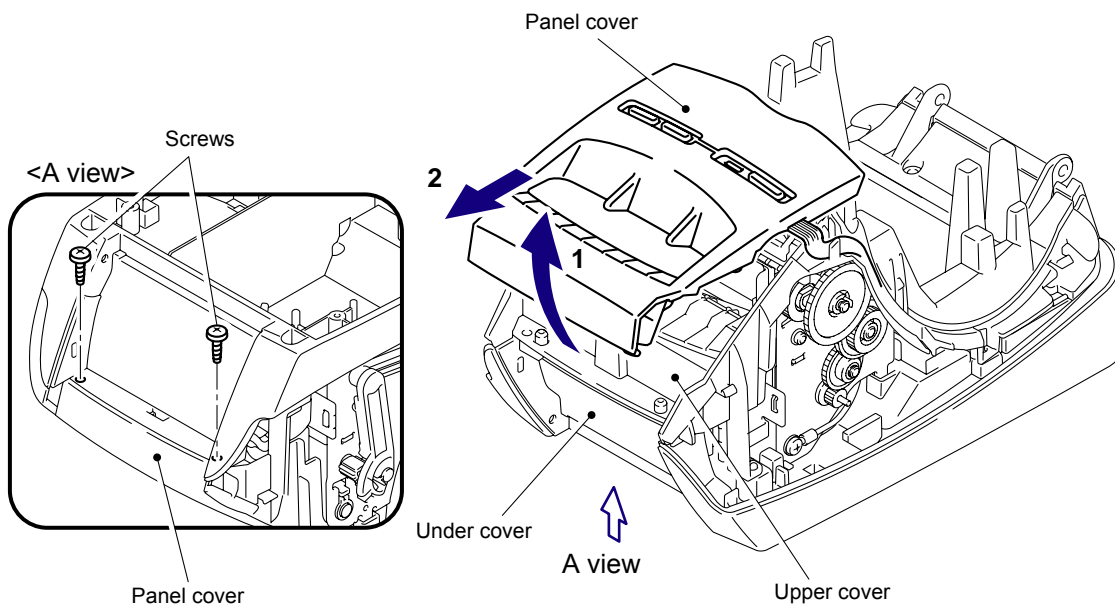

Fig.3.1-24 Removing the Panel Cover (1)

- (2) Turn the panel cover upside down.
- (3) Remove the three screws, and then remove the SB PCB ASSY from the panel cover.

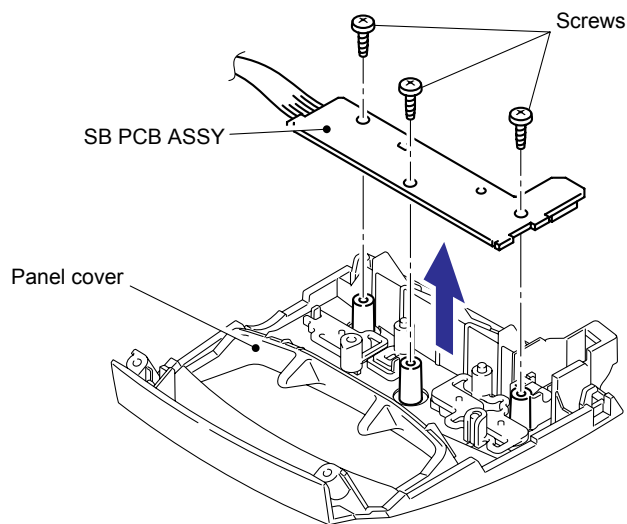
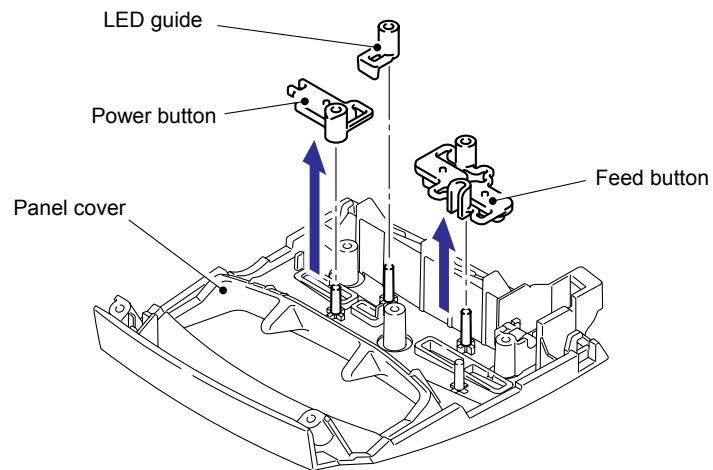

Fig.3.1-25 Removing the Panel Cover (2)

- (4) Remove the power button, feed button and LED guide from the panel cover.



**Fig.3.1-26 Removing the Panel Cover (3)**

- (5) Remove the cover sensor arm from the panel cover.

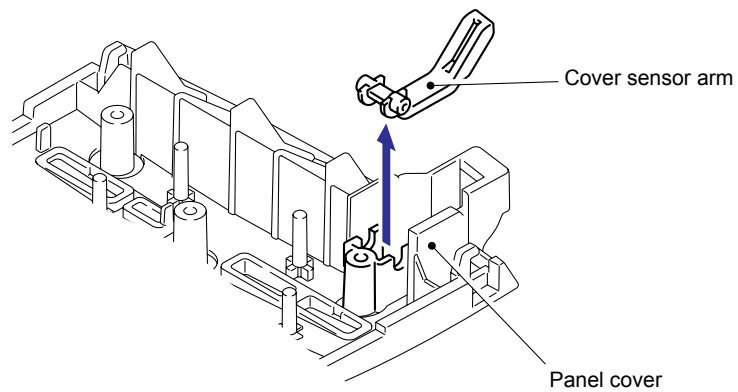
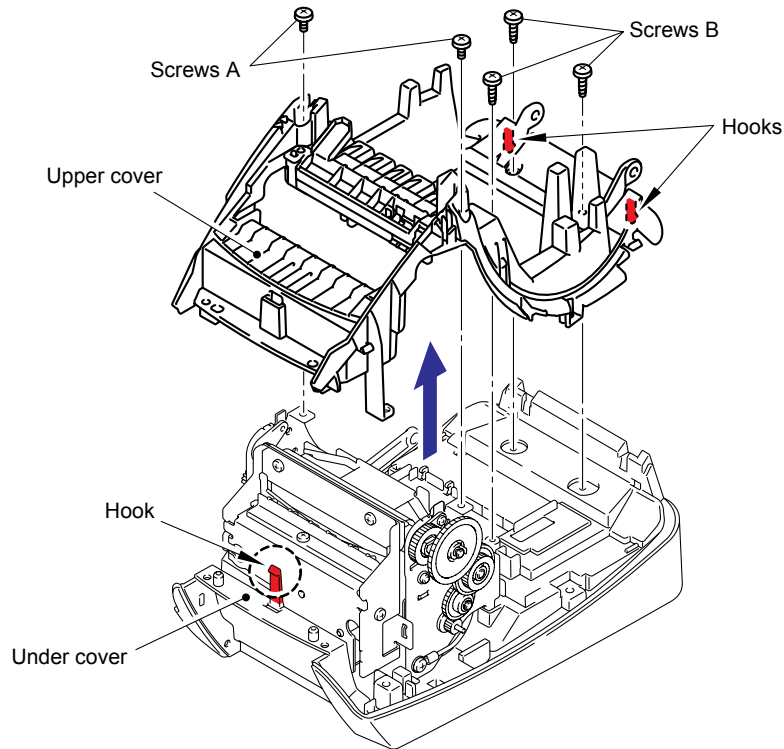

**Fig.3.1-27 Removing the Panel Cover (4)**

## [ 8 ] Removing the Upper Cover

- (1) Remove the two screws A and three screws B from the upper cover.
- (2) Release the three hooks to remove the upper cover from the under cover.

*Note: The screws A are screw, bind B M2.6x4. The screws B are taptite, bind B M2.6x6.*



**Fig.3.1-28 Removing the Upper Cover (1)**

- (3) Turn the upper cover upside down, and remove the filament tape which secures the harness of the tape sensor PCB ASSY.

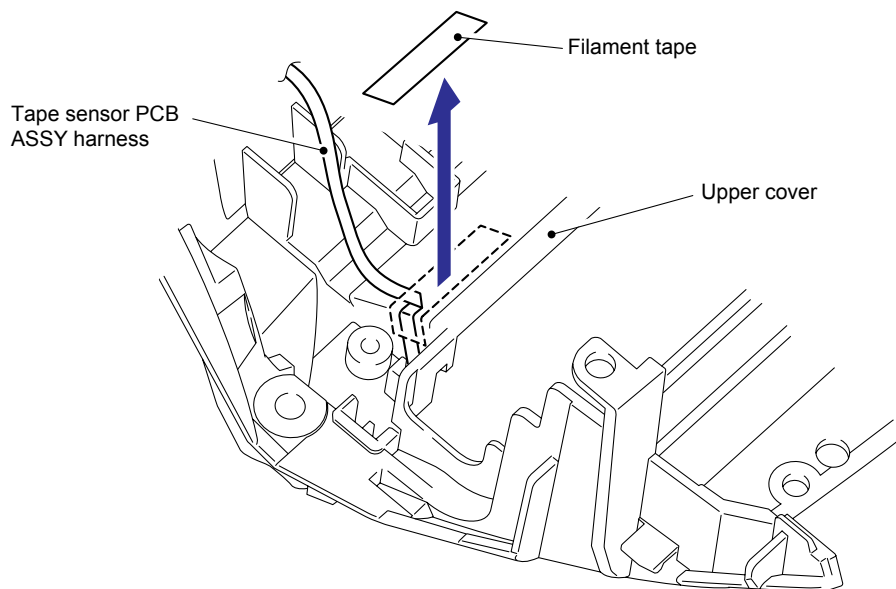

**Fig.3.1-29 Removing the Upper Cover (2)**

- (4) Remove the two screws, and then remove the insert guide from the upper cover.

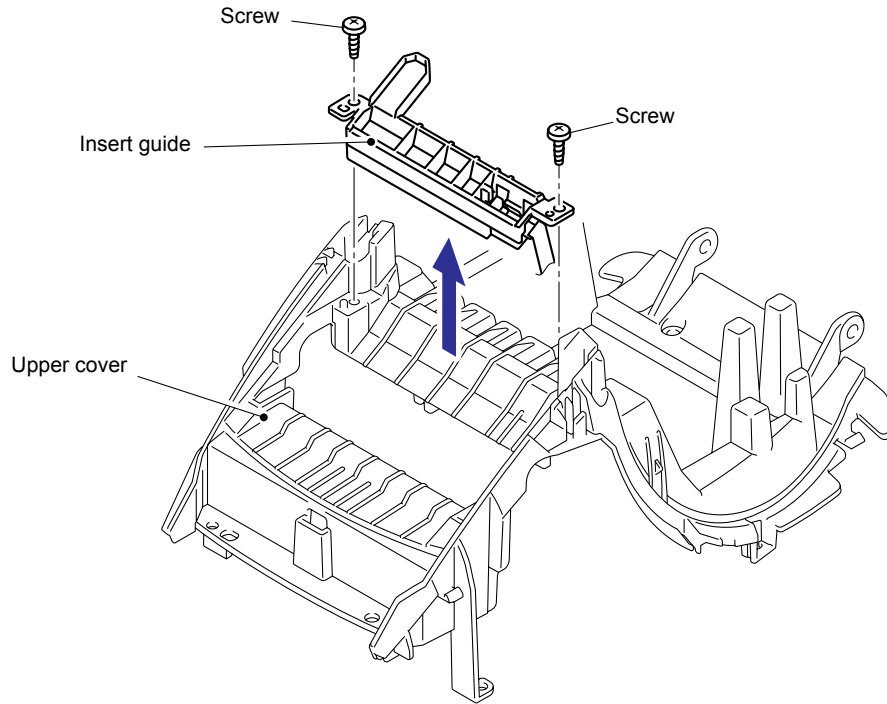

**Fig.3.1-30 Removing the Upper Cover (3)**

- (5) Remove the tape sensor PCB ASSY from the insert guide.

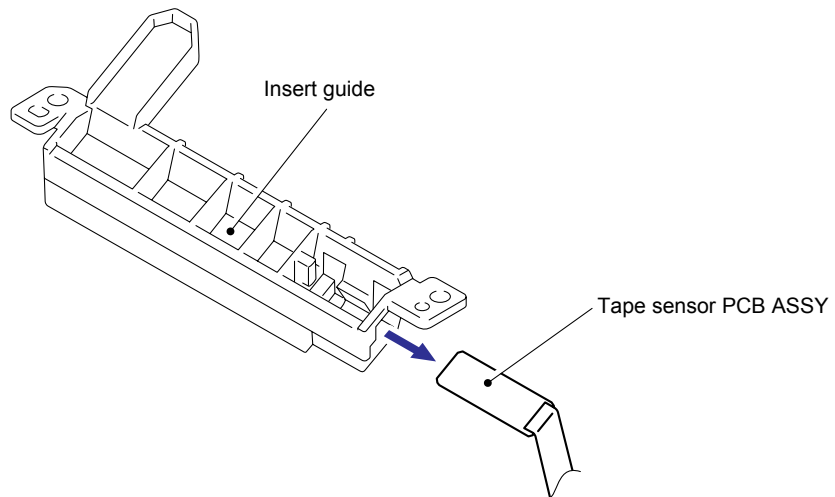

**Fig.3.1-31 Removing the Upper Cover (4)**

**[ 9 ] Removing the Mecha ASSY**

- (1) Remove the two screws, and then remove the mecha ASSY from the under cover.

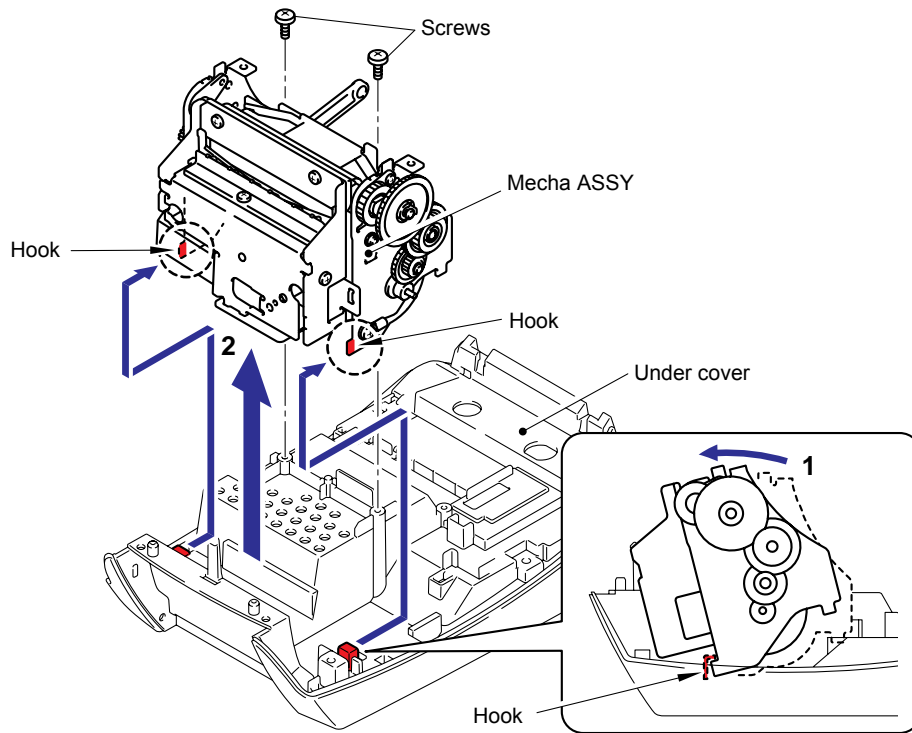

**Fig.3.1-32 Removing the Mecha ASSY**

## [ 10 ] Removing the Cutter Unit ASSY

- (1) Remove the two screws, and then remove the cutter unit ASSY from the mecha ASSY.

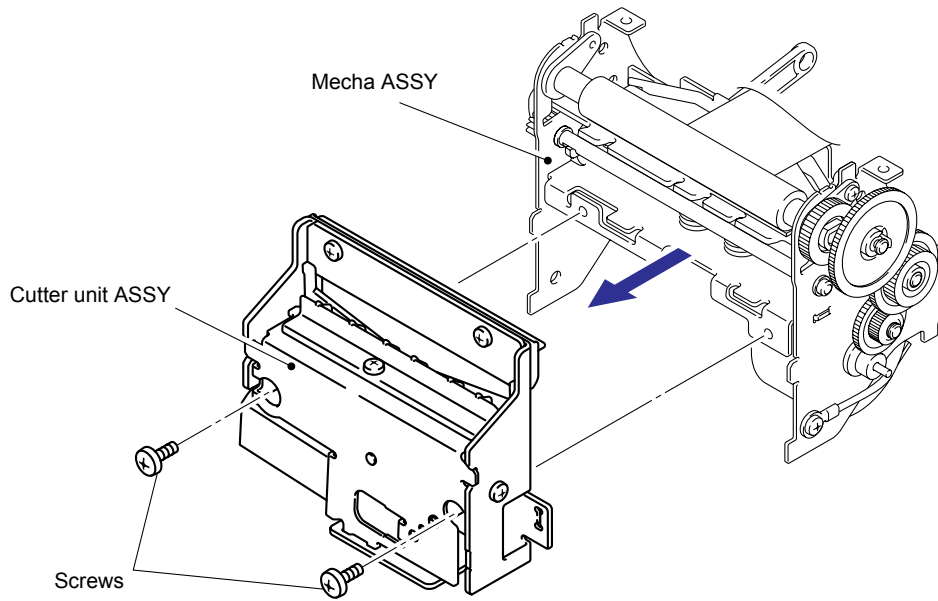

**Fig.3.1-33 Removing the Cutter Unit ASSY (1)**

- (2) Remove the cutter caution label from the cutter unit ASSY.

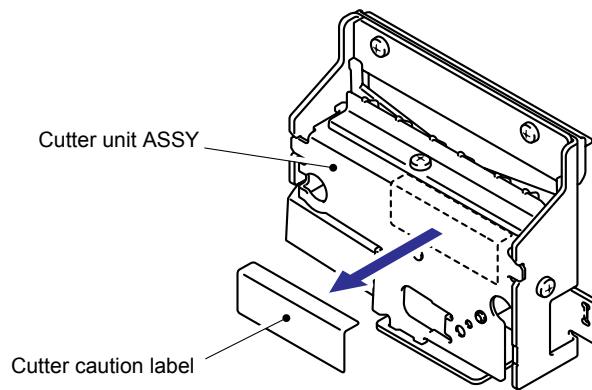

**Fig.3.1-34 Removing the Cutter Unit ASSY (2)**

**[ 11 ] Disassembly of the Mecha ASSY**

- (1) Release the hook and remove the double gear C from the mecha ASSY.

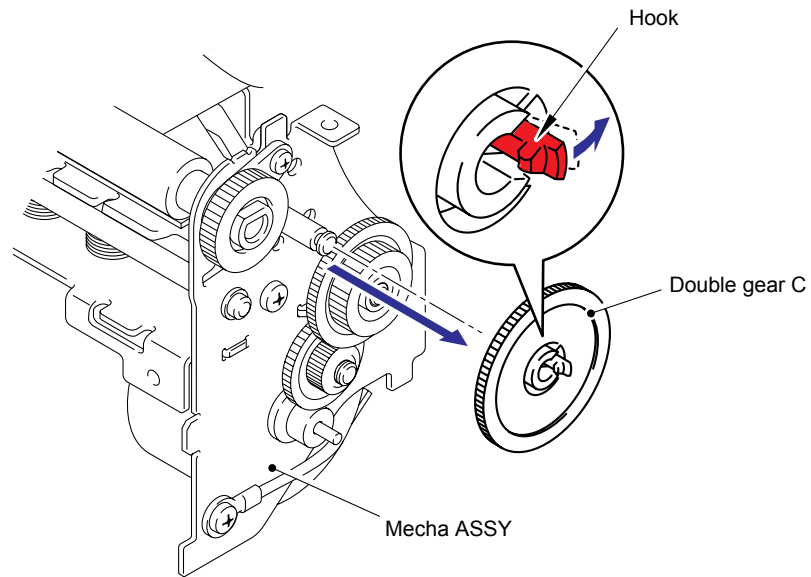

**Fig.3.1-35 Disassembly of the Mecha ASSY (1)**

- (2) Remove the double gear B and platen gear in the sequence from mecha ASSY.

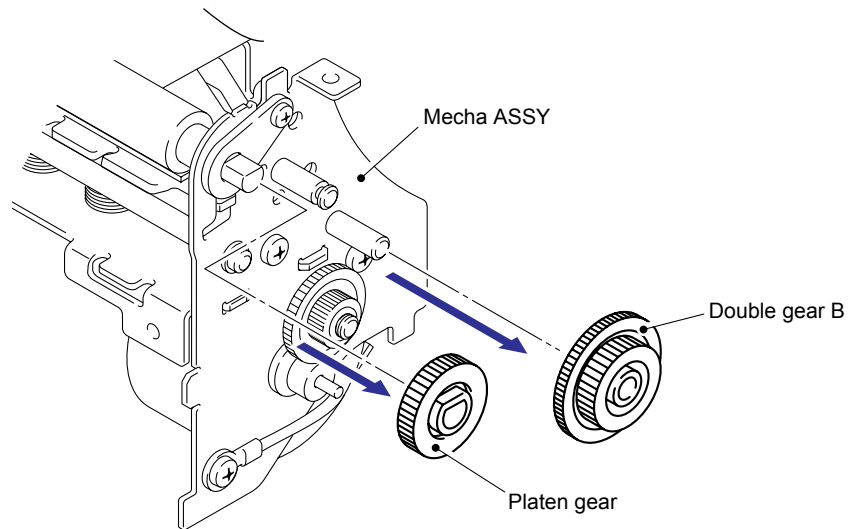

**Fig.3.1-36 Disassembly of the Mecha ASSY (2)**



- (3) Remove a screw from the platen shaft bush on the right side to remove the platen shaft bush (right side).

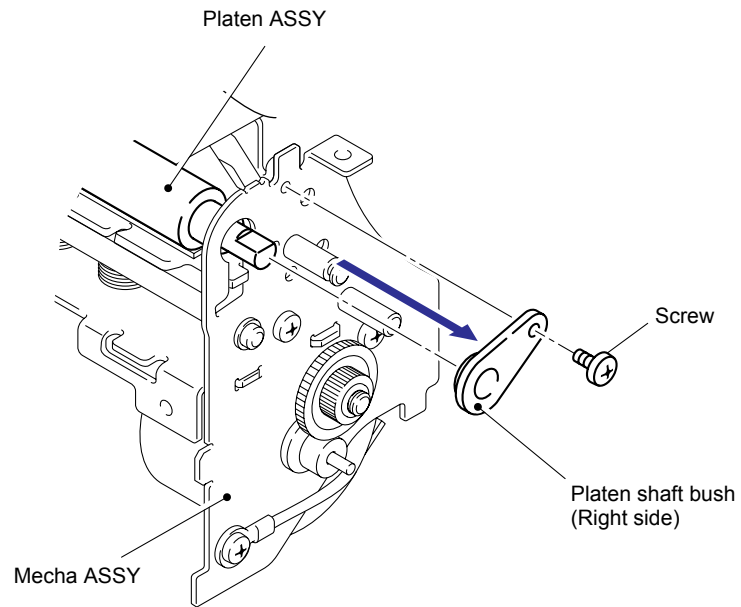

**Fig.3.1-37 Disassembly of the Mecha ASSY (3)**

- (4) Remove the platen shaft bush (left side) and platen ASSY from the mecha ASSY.

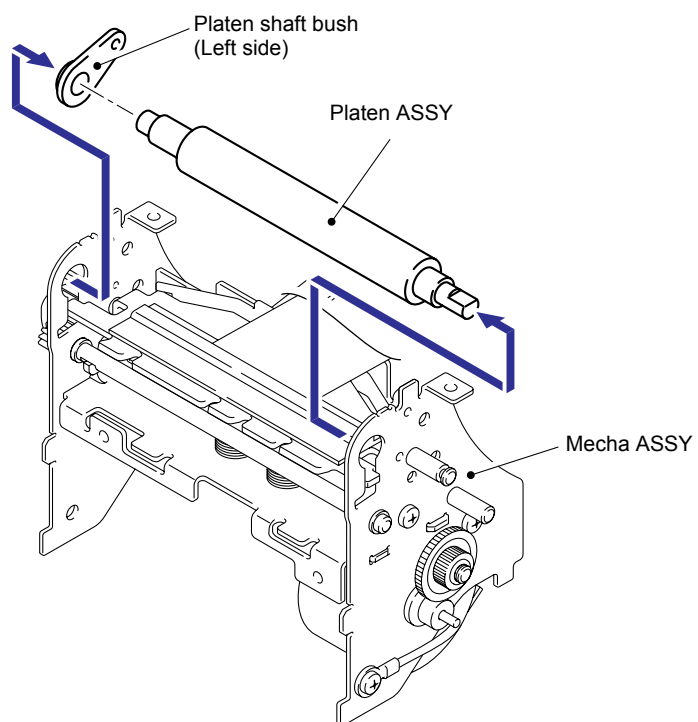

**Fig.3.1-38 Disassembly of the Mecha ASSY (4)**

(5) Remove the head hold spring from the mecha ASSY.

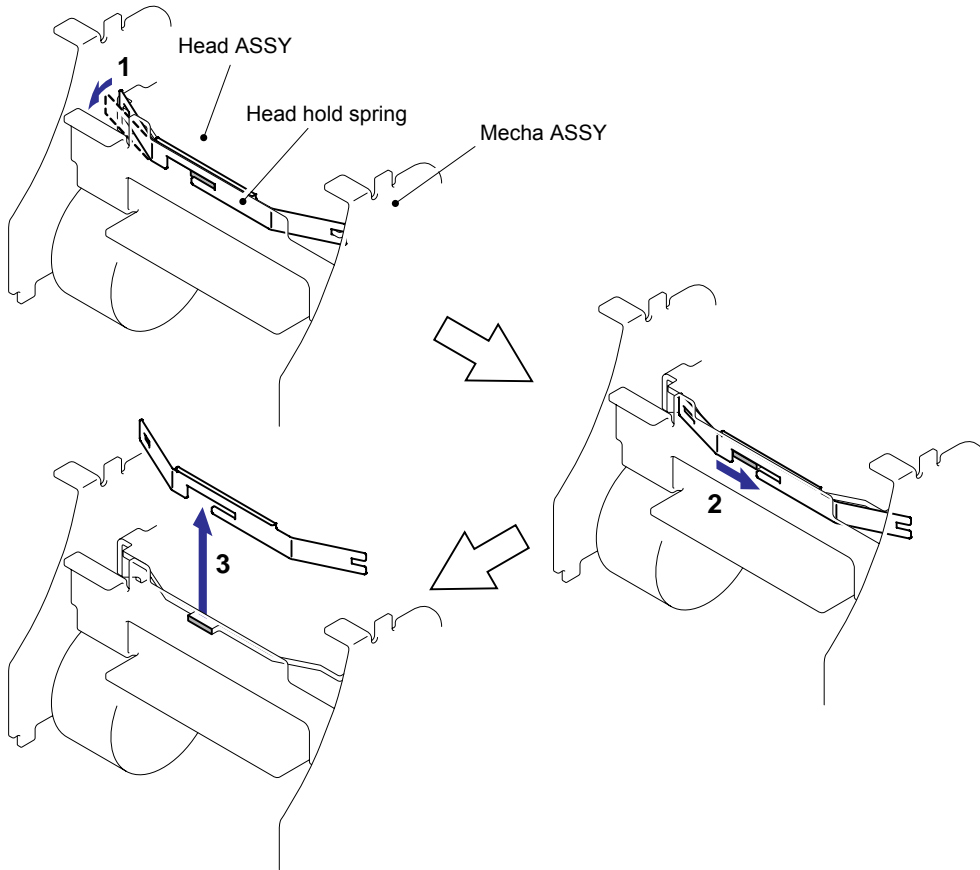

Fig.3.1-39 Disassembly of the Mecha ASSY (5)

(6) Remove the head ASSY from the mecha ASSY.

**Caution:** Pay attention not to give strong impact on the heating element of a head ASSY when removing the head ASSY.

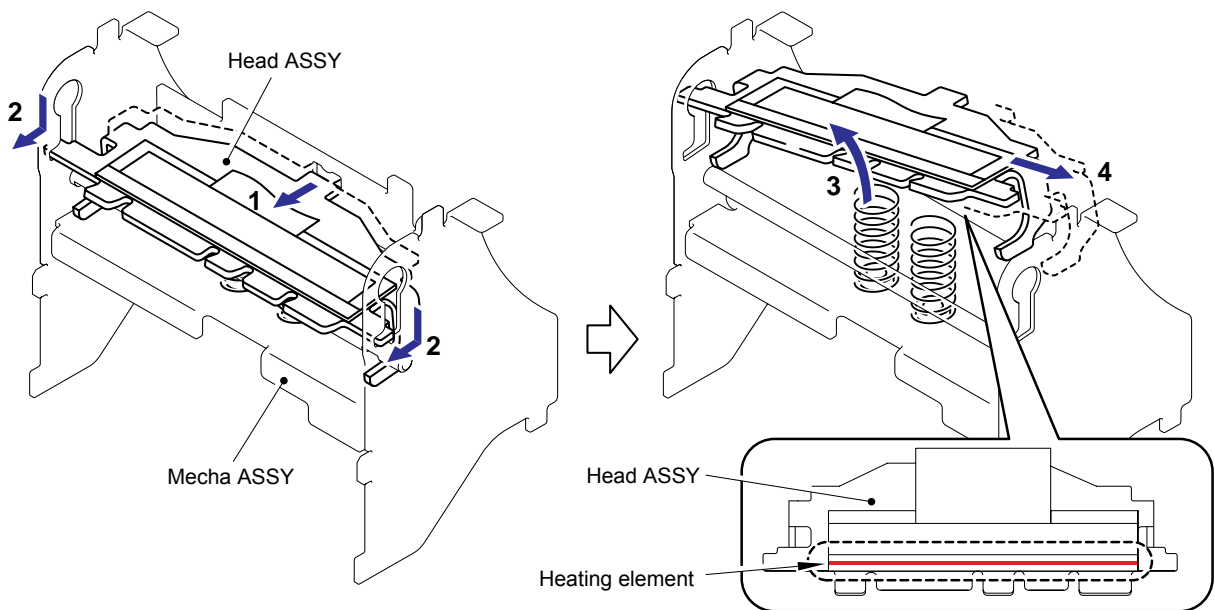
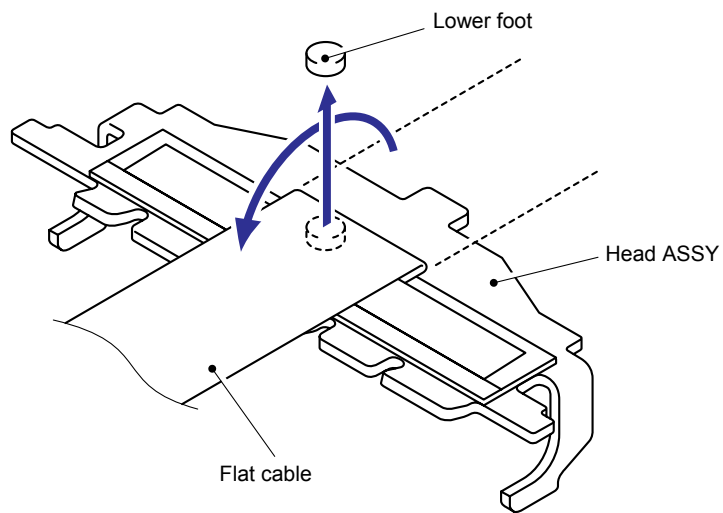

Fig.3.1-40 Disassembly of the Mecha ASSY (6)

- (7) Remove the one lower foot from the bottom of the flat cable of the head ASSY.



**Fig.3.1-41 Disassembly of the Mecha ASSY (7)**

- (8) Remove the two head springs L from the mecha ASSY.

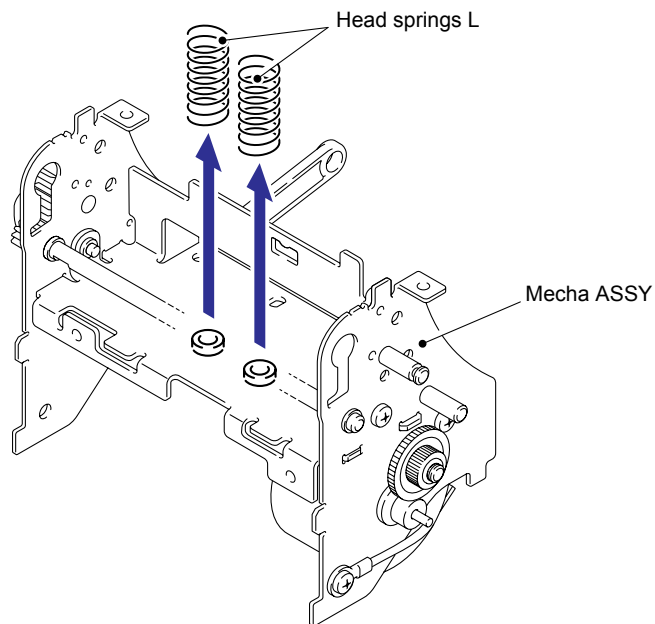

**Fig.3.1-42 Disassembly of the Mecha ASSY (8)**

(9) Remove the retaining ring E2.5 and remove the double gear A from the mecha ASSY.

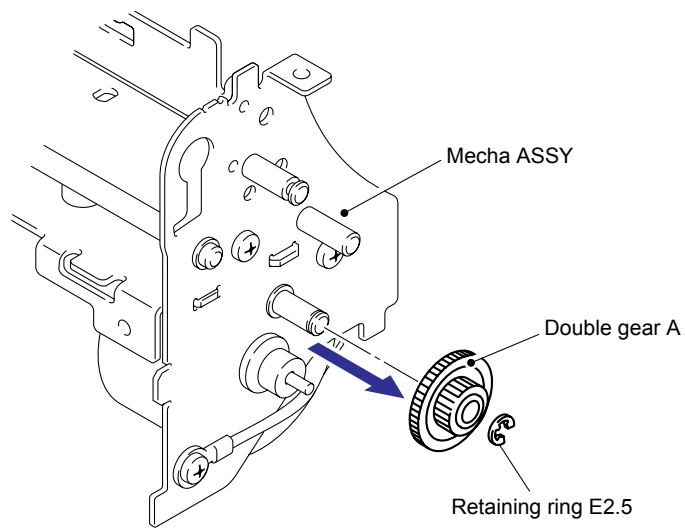

**Fig.3.1-43 Disassembly of the Mecha ASSY (9)**

(10) Remove two screws, and then remove the tape feed motor ASSY and FG harness ASSY.

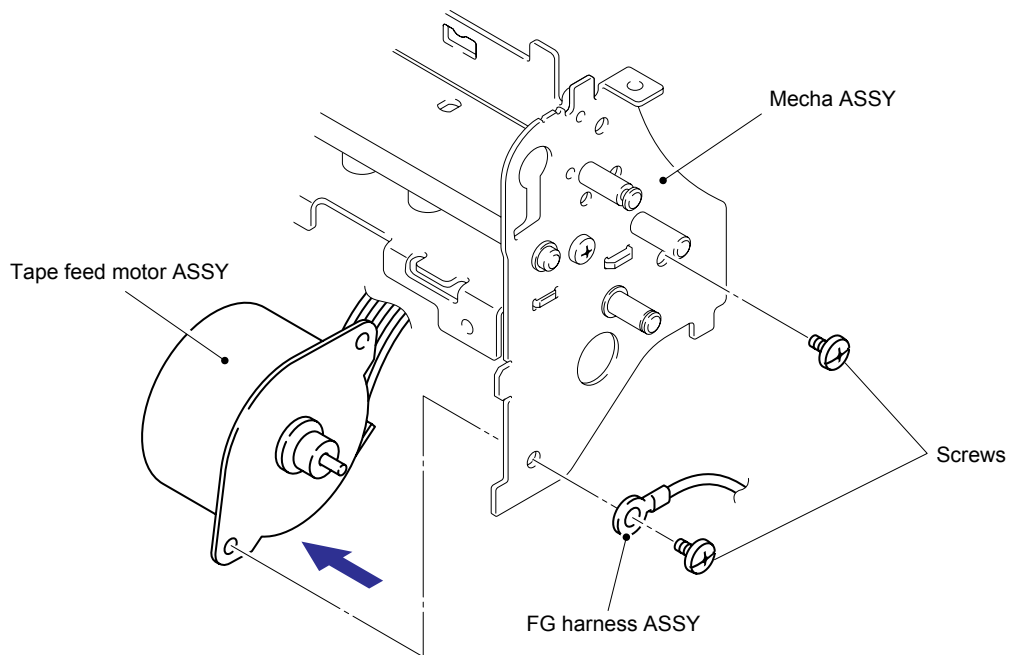

**Fig.3.1-44 Disassembly of the Mecha ASSY (10)**

### 3.5 REASSEMBLING PROCEDURE

#### [ 1 ] Reassembling the Mecha ASSY

- (1) Assemble the tape feed motor ASSY and FG harness ASSY onto the mecha ASSY with the two screws.

*Note: Pay attention to the direction of the tape feed motor ASSY.*

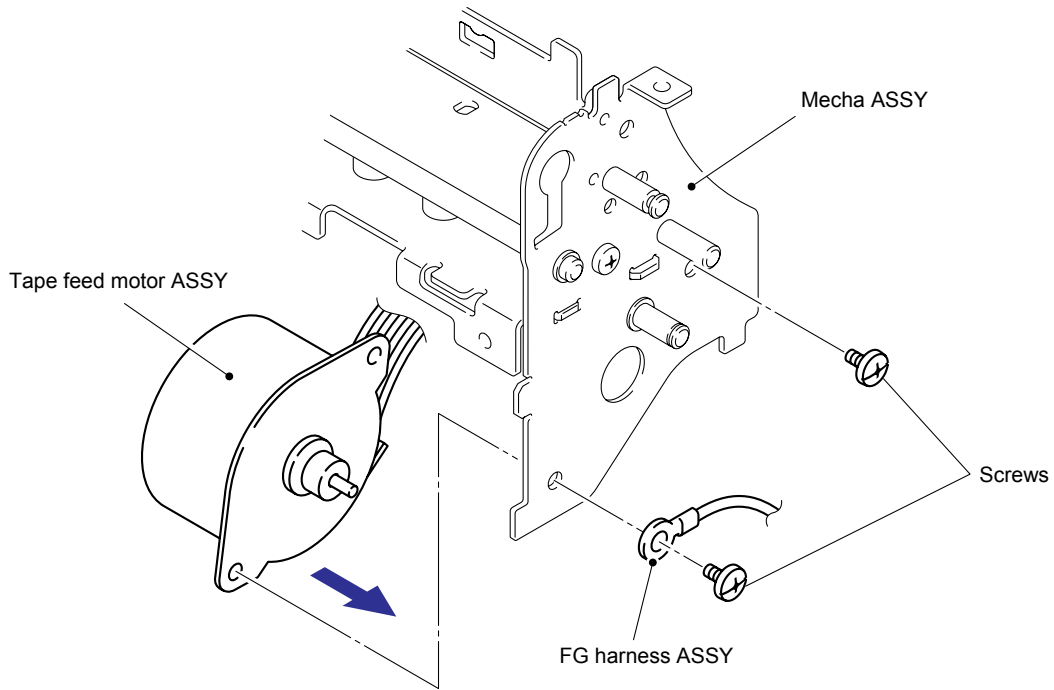
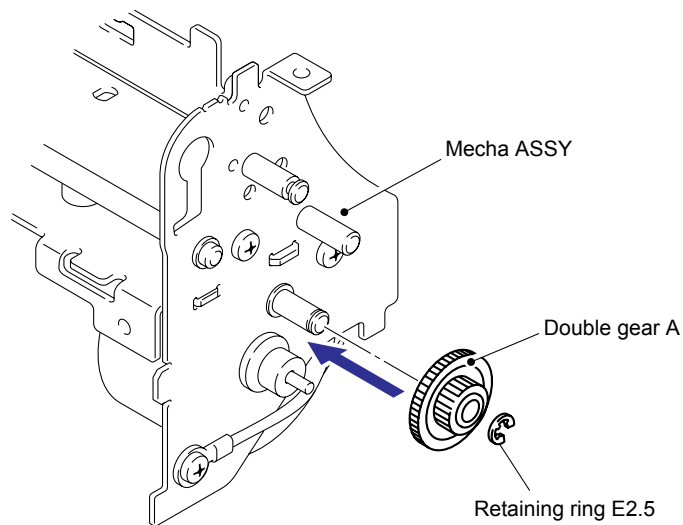

**Fig.3.2-1 Reassembling of the Mecha ASSY (1)**

- (2) Assemble the double gear A onto the shaft of the mecha ASSY with the one retaining ring E2.5.

*Note1: Confirm that the retaining ring E2.5 is firmly assembled.*

*Note2: Confirm that each gear moves smoothly.*



**Fig.3.2-2 Reassembling of the Mecha ASSY (2)**

- (3) Turn over the flat cable of the head ASSY, and assemble the lower foot.

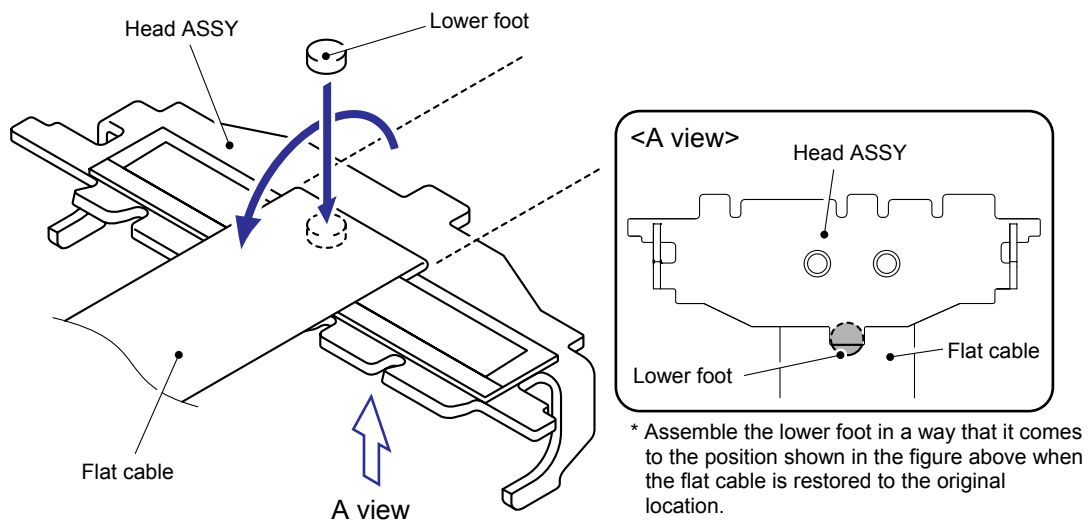

**Fig.3.2-3 Reassembling of the Mecha ASSY (3)**

- (4) Assemble the two head springs L onto the bosses of the mecha ASSY.

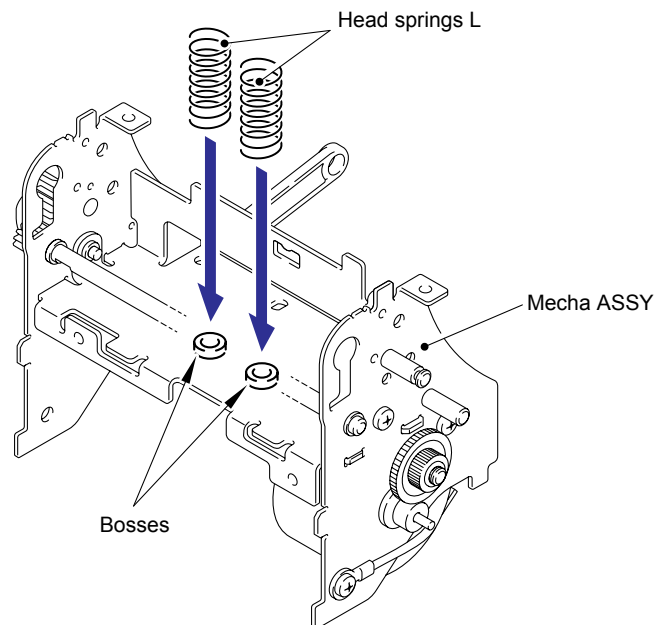
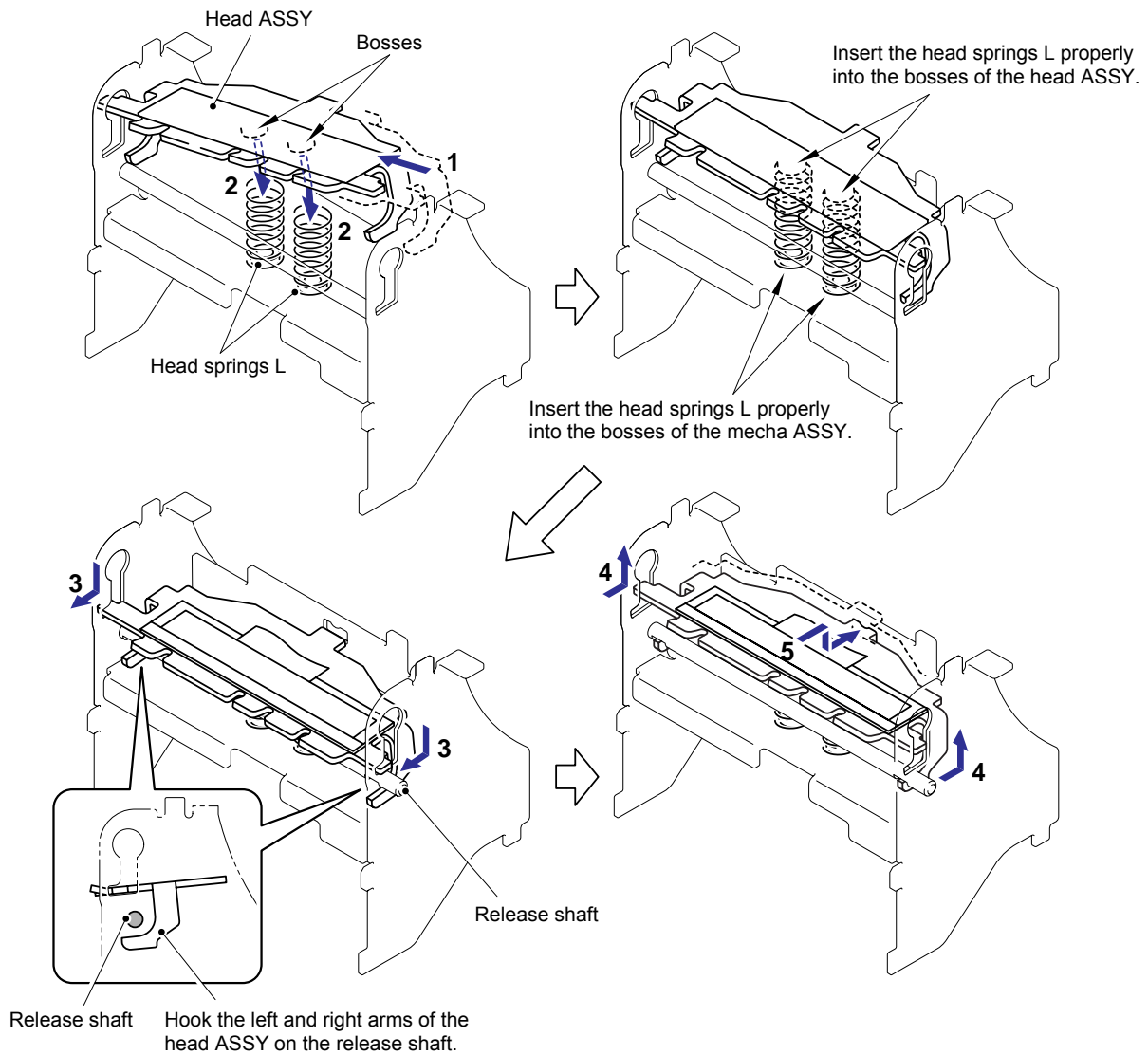

**Fig.3.2-4 Reassembling of the Mecha ASSY (4)**

- (5) Set the two head springs L on the bosses of the head ASSY, and assemble the head ASSY onto the mecha ASSY as shown in the figure.

*Note1: Confirm that the head ASSY moves smoothly*

*Note2: Confirm that the head springs L are properly inserted into the upper and lower bosses.*



**Caution: Pay attention not to give strong impact on the heating element of a head ASSY when mounting the head ASSY.**

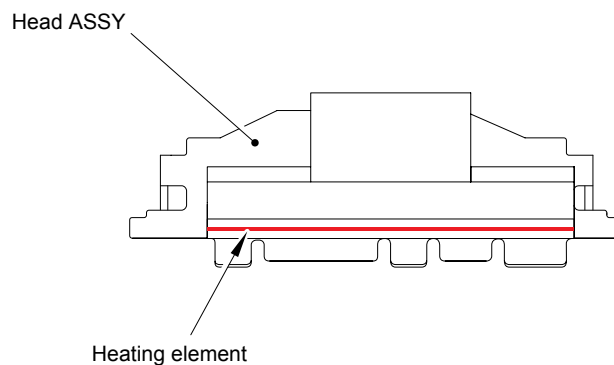

**Fig.3.2-5 Reassembling of the Mecha ASSY (5)**

(6) Assemble the head hold spring onto the mecha ASSY as shown in the figure.

*Note: Be careful not to cut your fingers.*

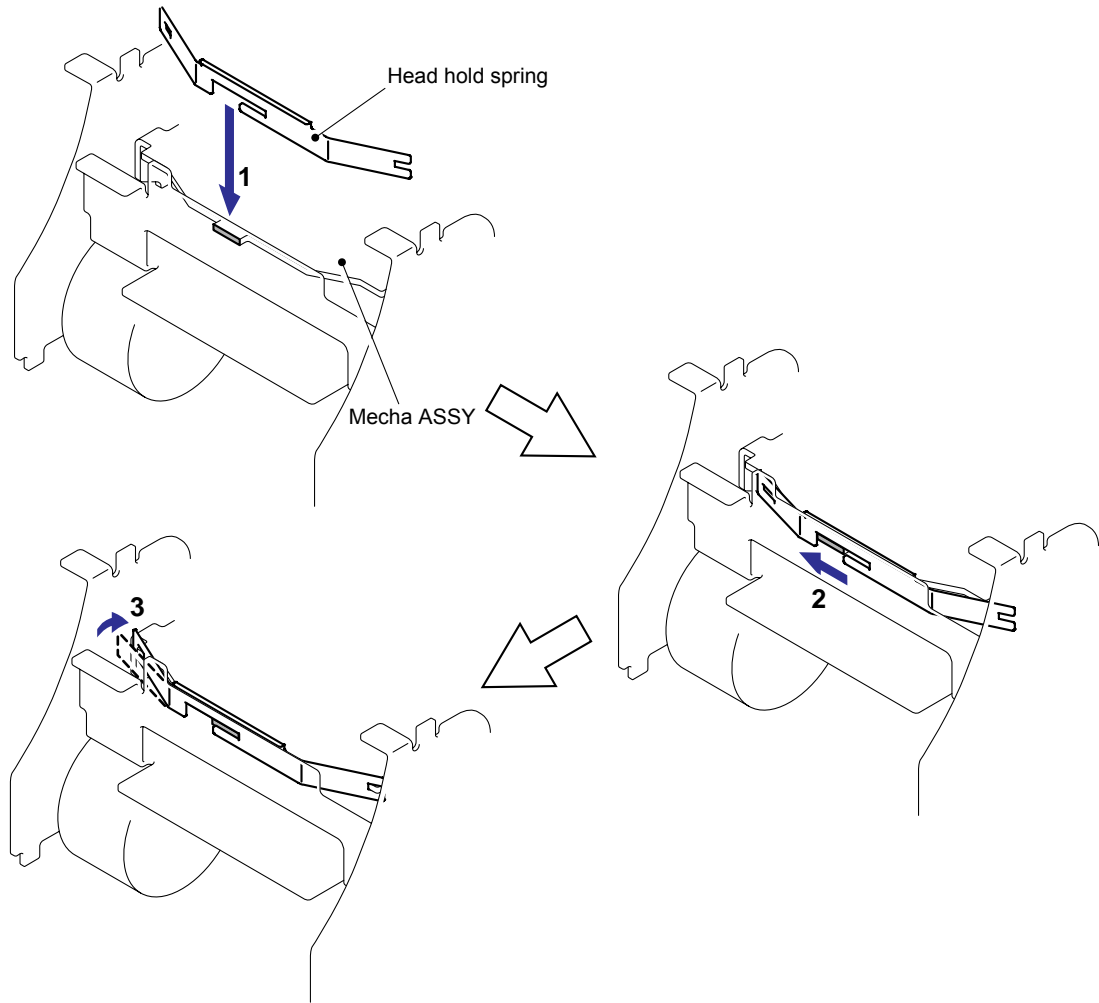

**Fig.3.2-6 Reassembling of the Mecha ASSY (6)**



- (7) Assemble the platen shaft bush (left side) to the mecha ASSY.
- (8) Assemble the platen ASSY to the mecha ASSY.

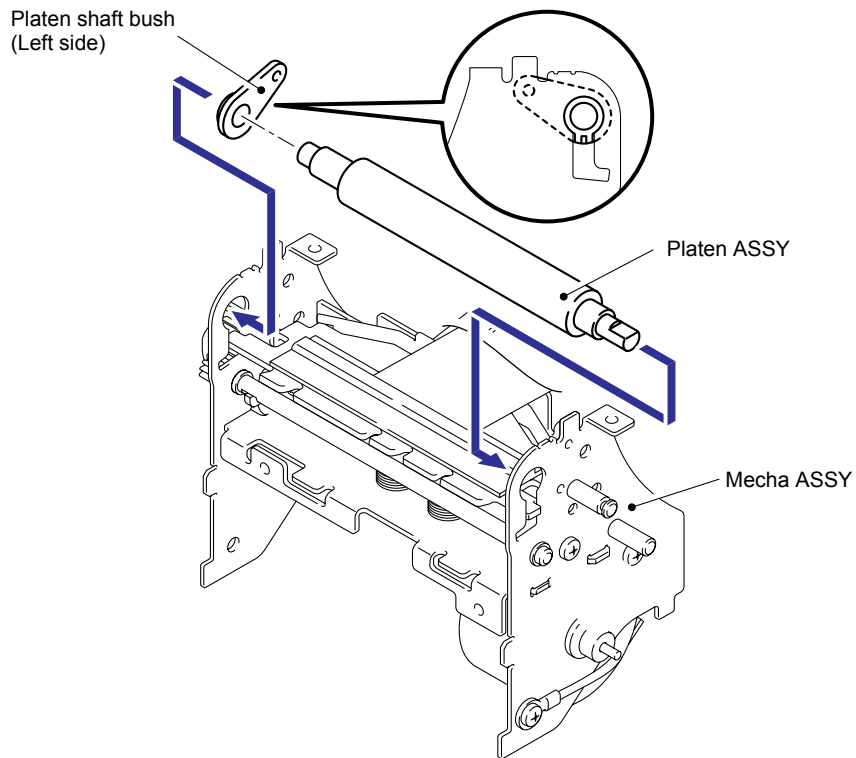

**Fig.3.2-7 Reassembling of the Mecha ASSY (7)**

- (9) Assemble the platen shaft bush (right side) to the mecha ASSY by screw.

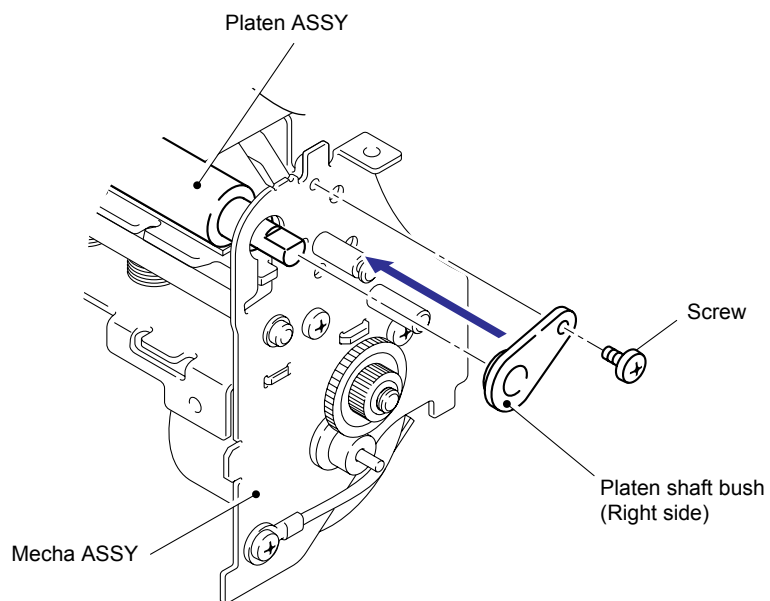
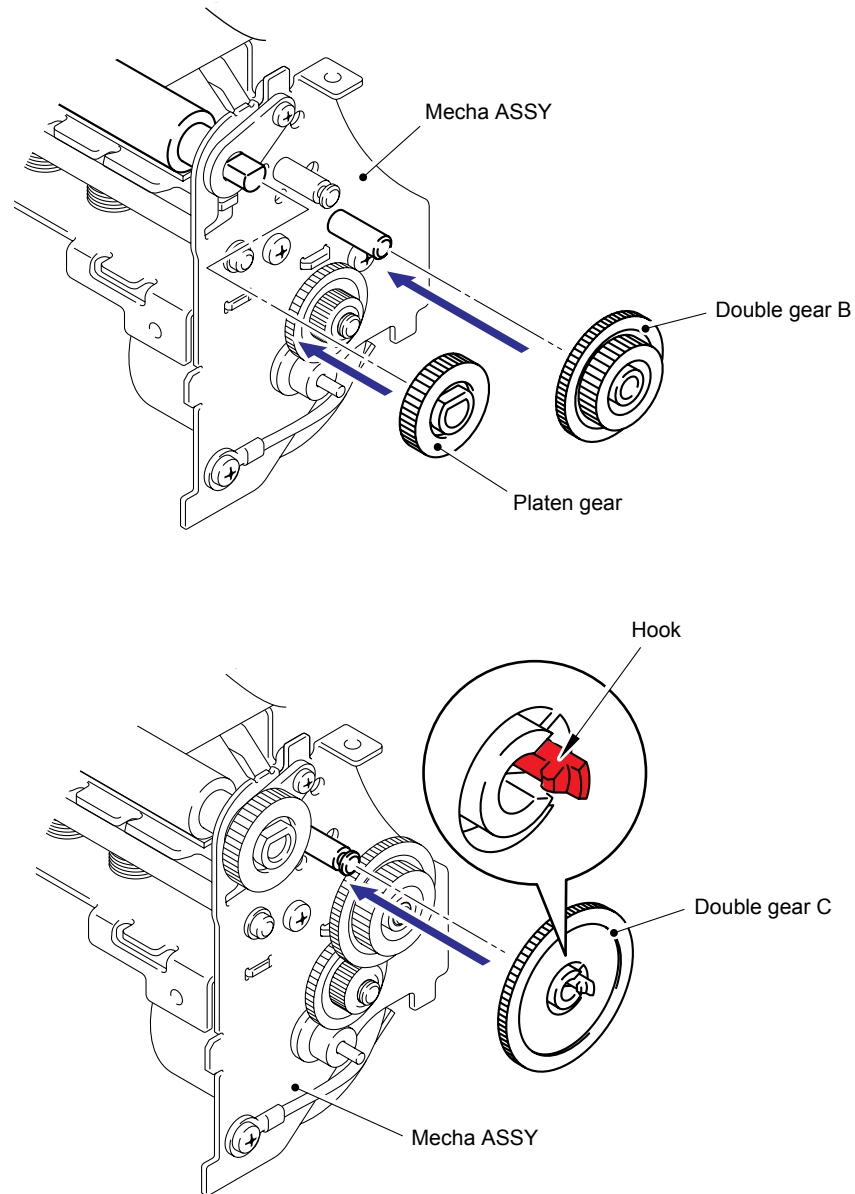

**Fig.3.2-8 Reassembling of the Mecha ASSY (8)**

(10) Assemble the platen gear, double gear B, and double gear C onto the mecha ASSY in this order.

*Note1: Confirm that the hook of the double gear C is securely hooked on.*

*Note2: Confirm that each gear moves smoothly.*



**Fig.3.2-9 Reassembling of the Mecha ASSY (9)**

## [ 2 ] Installing the Cutter Unit ASSY

- (1) Attach the cutter caution label onto the cutter unit ASSY.

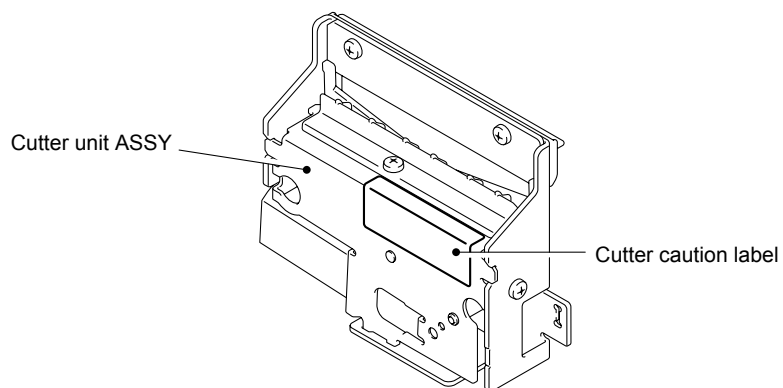

**Fig.3.2-10 Installing the Cutter Unit ASSY (1)**

- (2) Assemble the cutter unit ASSY onto the mecha ASSY with the two screws.

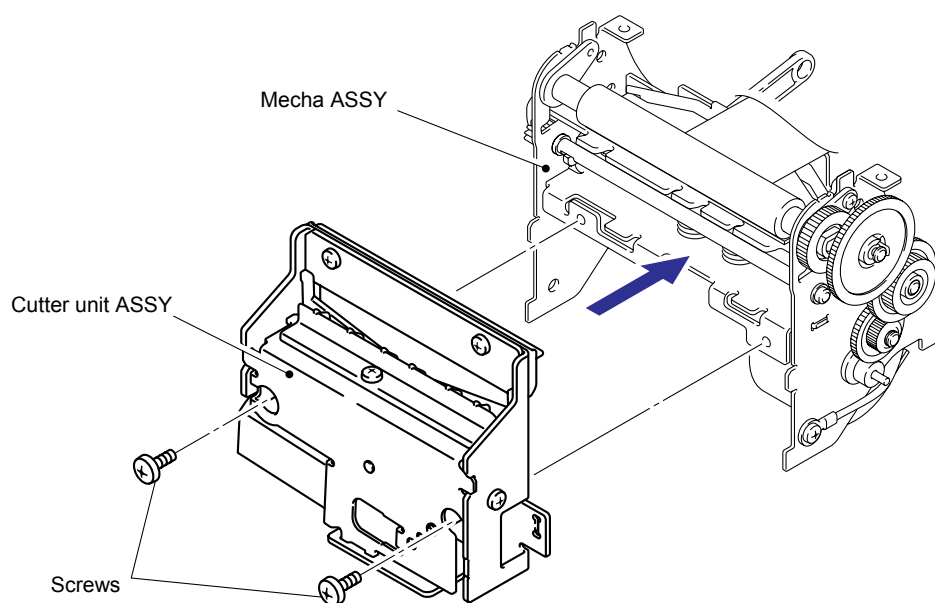

**Fig.3.2-11 Installing the Cutter Unit ASSY (2)**

### [ 3 ] Installing the Mecha ASSY

- (1) Set the two hooks A to the grooves on the under cover of the mecha ASSY.
- (2) Fit the hole of the mecha ASSY into the boss on the under cover, and insert the two hooks B of the mecha ASSY into the holes on the under cover.
- (3) Secure the mecha ASSY with the two screws.

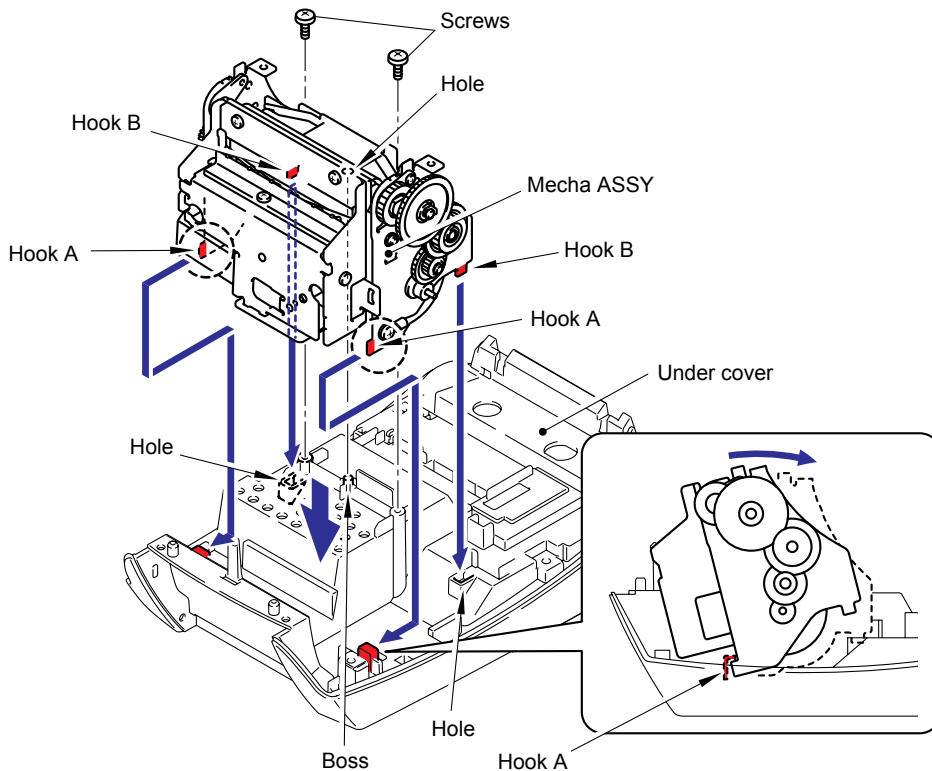

**Fig.3.2-12 Installing the Mecha ASSY (1)**

- (4) Put the harnesses of the mecha ASSY through the three holes of the under cover respectively as shown in the figure.

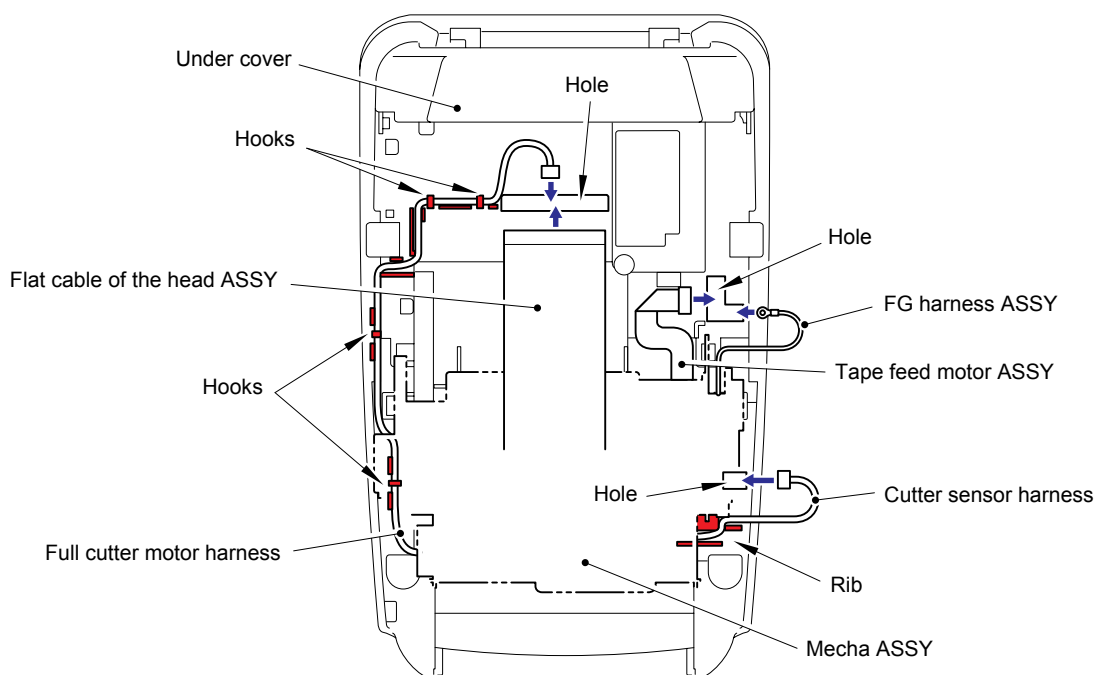

**Fig.3.2-13 Installing the Mecha ASSY (2)**

#### [ 4 ] Installing the Upper Cover

- (1) Insert the tape sensor PCB ASSY into the insert guide.

*Note1: Insert the tape sensor PCB ASSY until it hits the groove of the insert guide.*

*Note2: Confirm that you can see the tape sensor PCB ASSY from the hold of the insert guide.*

*Note3: Fold the flat cable after assembling the tape sensor PCB ASSY.*

**Important: When replacing the tape sensor PCB ASSY, and then check the items using the "MAINTENANCE SOFTWARE OPERATION" in APPENDIX 1.**

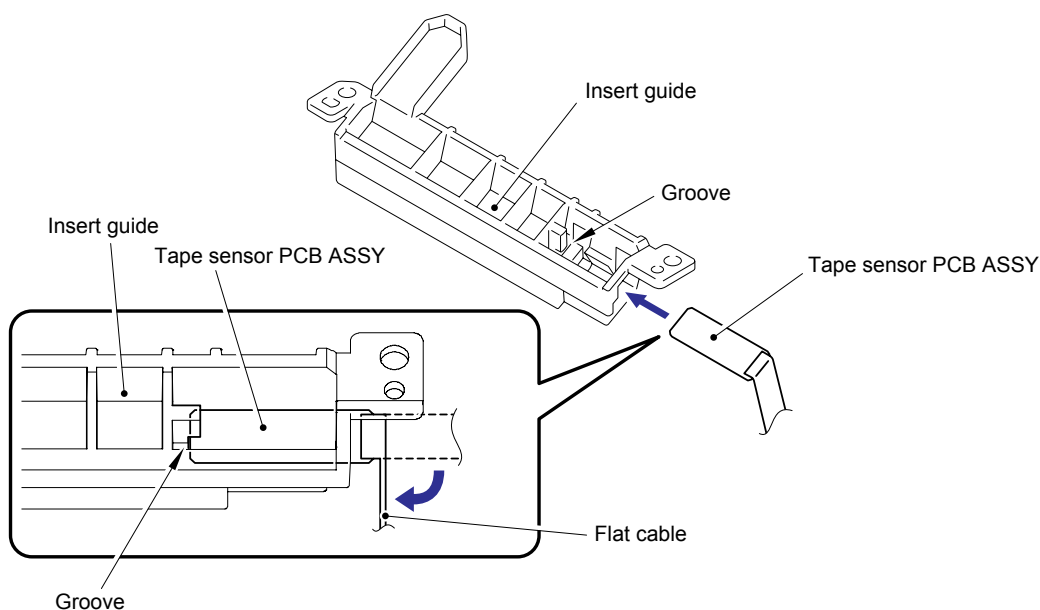

Fig.3.2-14 Installing the Upper Cover (1)

- (2) Put the flat cable of tape sensor PCB ASSY into the hole on the upper cover.
- (3) Assemble the insert guide onto the upper cover with the two screws.

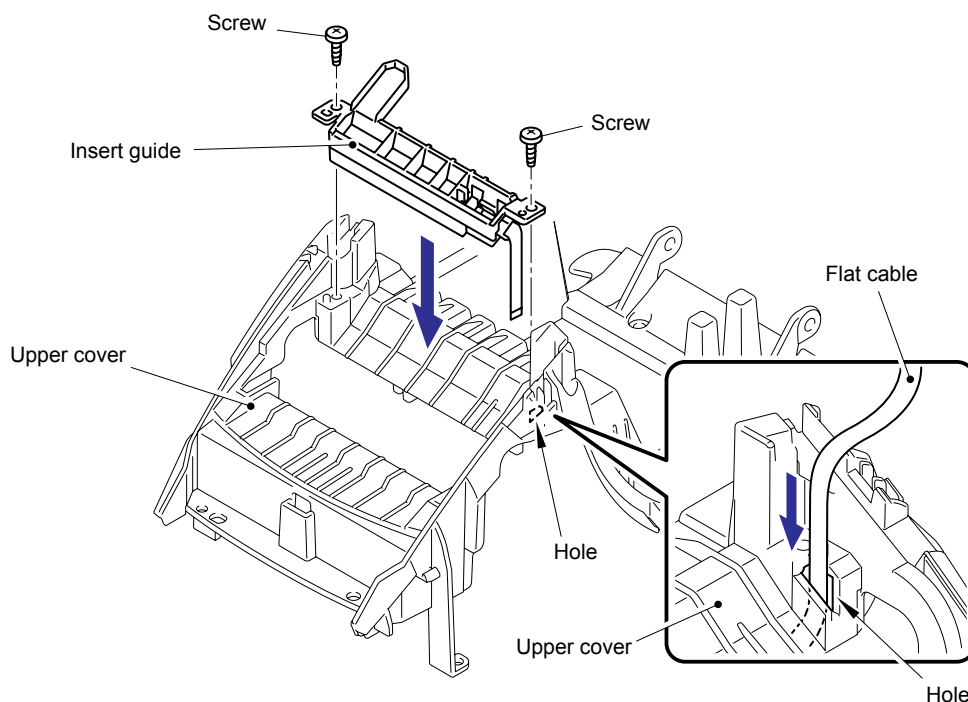
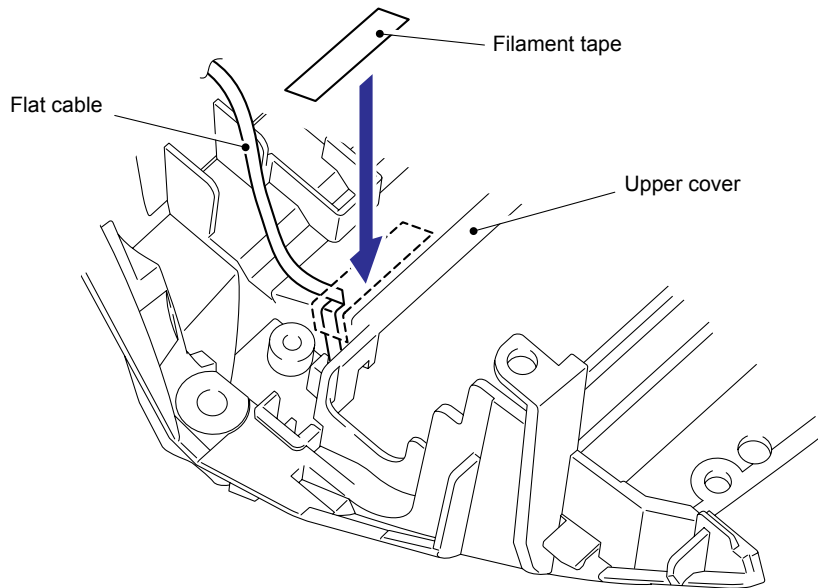

Fig.3.2-15 Installing the Upper Cover (2)

- (4) Bend the flat cable as shown in the figure, and secure it with filament tape on the back side of the upper cover.



**Fig.3.2-16 Installing the Upper Cover (3)**

- (5) Move the platen release lever and link lever to the position as shown in the figure. (The head is in a pressure contact state.)

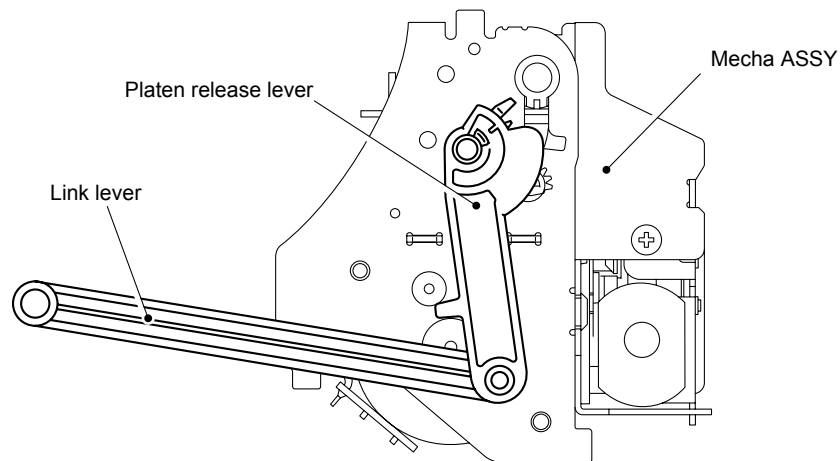

**Fig.3.2-17 Installing the Upper Cover (4)**

- (6) Put the flat cable of the tape sensor PCB ASSY through the portion A of the under cover.
- (7) Put the SB PCB harness through the portion B of the under cover.

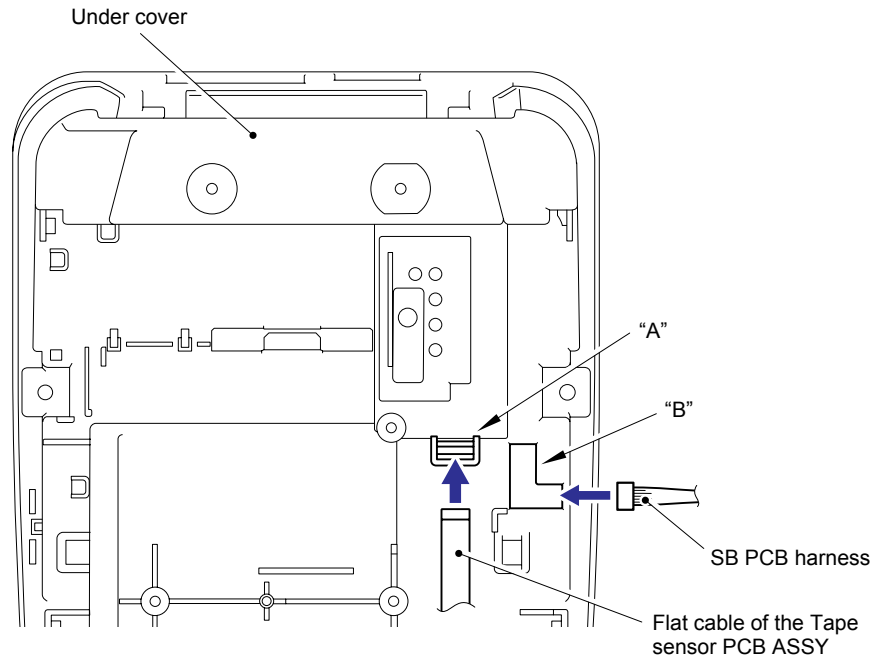

**Fig.3.2-18 Installing the Upper Cover (5)**

- (8) Pass the link lever through the hole B of the upper cover, and assemble the upper cover on the ribs of the under cover.
- (9) Tighten the upper cover with the two screws A and three screws B.

*Note: The screws A are screw, bind B M2.6x4. The screws B are taptite, bind B M2.6x6.*

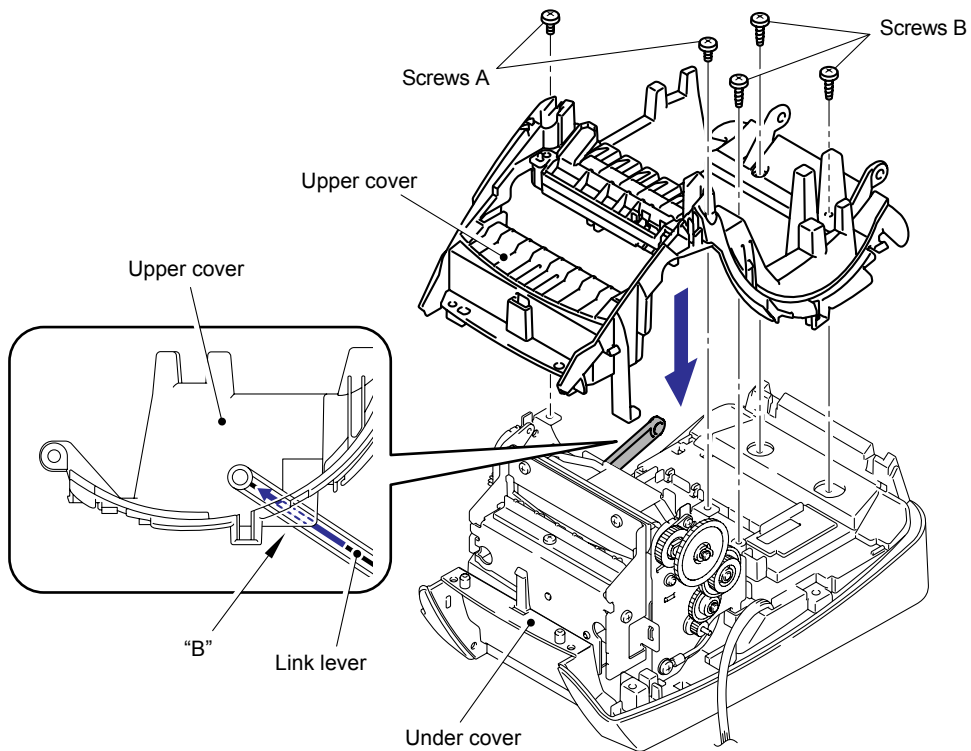

**Fig.3.2-19 Installing the Upper Cover (6)**

**[ 5 ] Installing the Panel Cover**

- (1) Assemble the power button, feed button and LED guide onto the panel cover.

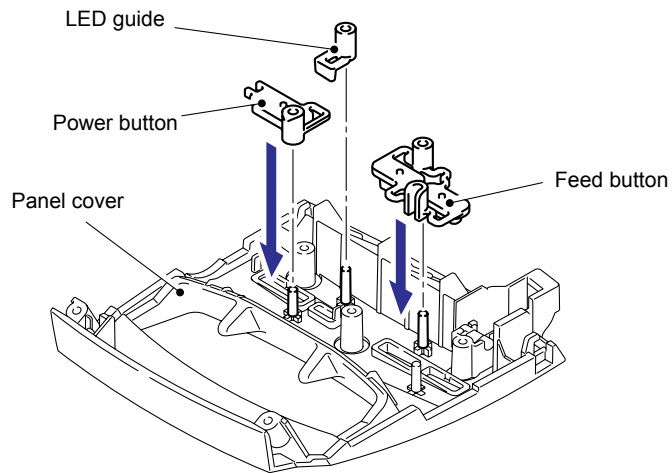

**Fig.3.2-20 Installing the Panel Cover (1)**

- (2) Assemble the shaft unit of the cover sensor arm to the portion A of the panel cover.

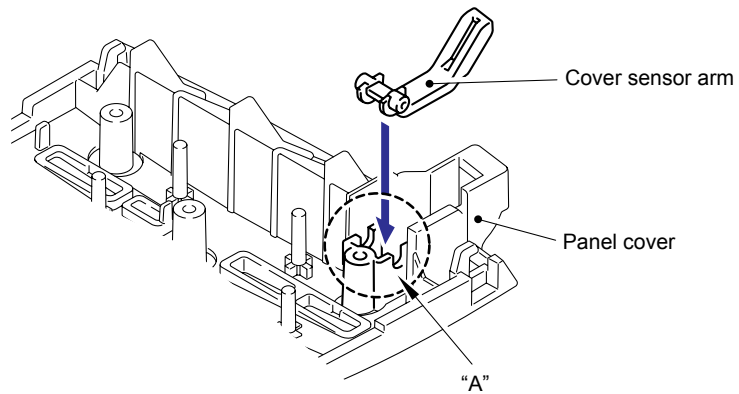
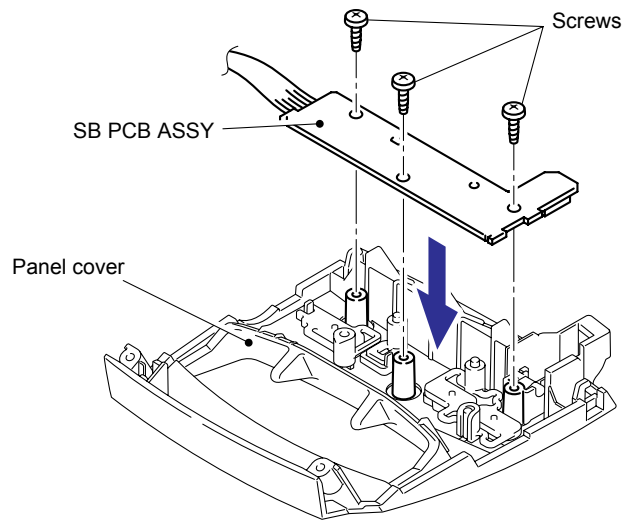

**Fig.3.2-21 Installing the Panel Cover (2)**



- (3) Assemble the SB PCB ASSY onto the panel cover with the three screws.

*Note: Confirm that the Cover sensor arm moves smoothly.*



**Fig.3.2-22 Installing the Panel Cover (3)**

- (4) Insert the two hooks of the panel cover into the holes of the upper cover.

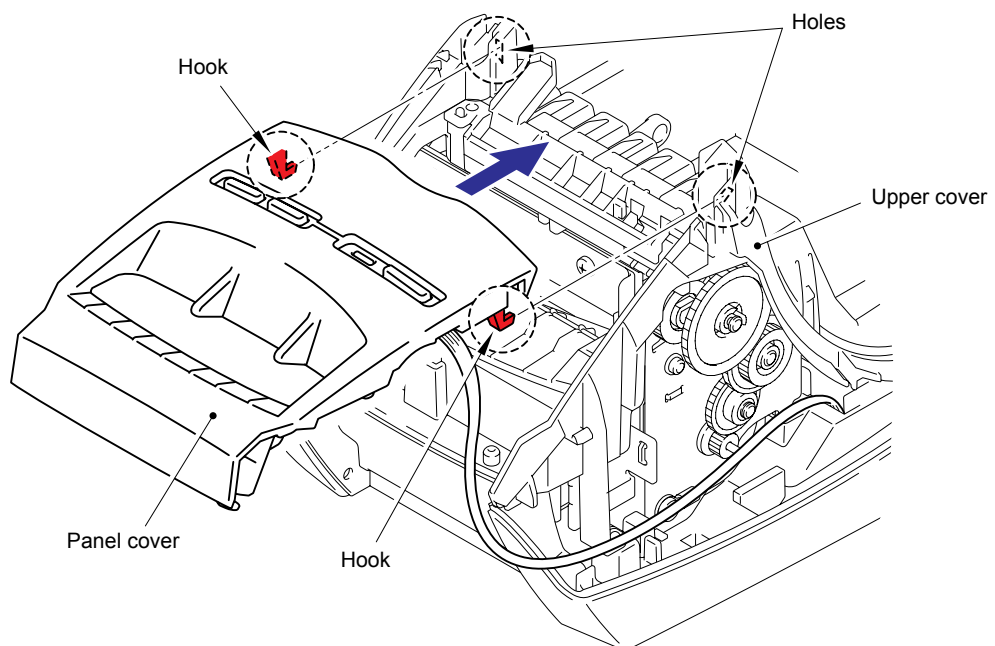

**Fig.3.2-23 Installing the Panel Cover (4)**

- (5) Rotate the panel cover using the hooks as fulcrums, and assemble it onto the upper cover.
  - (6) Secure the panel cover with the two screws.
- Note: Confirm that the harnesses are not pinched.*

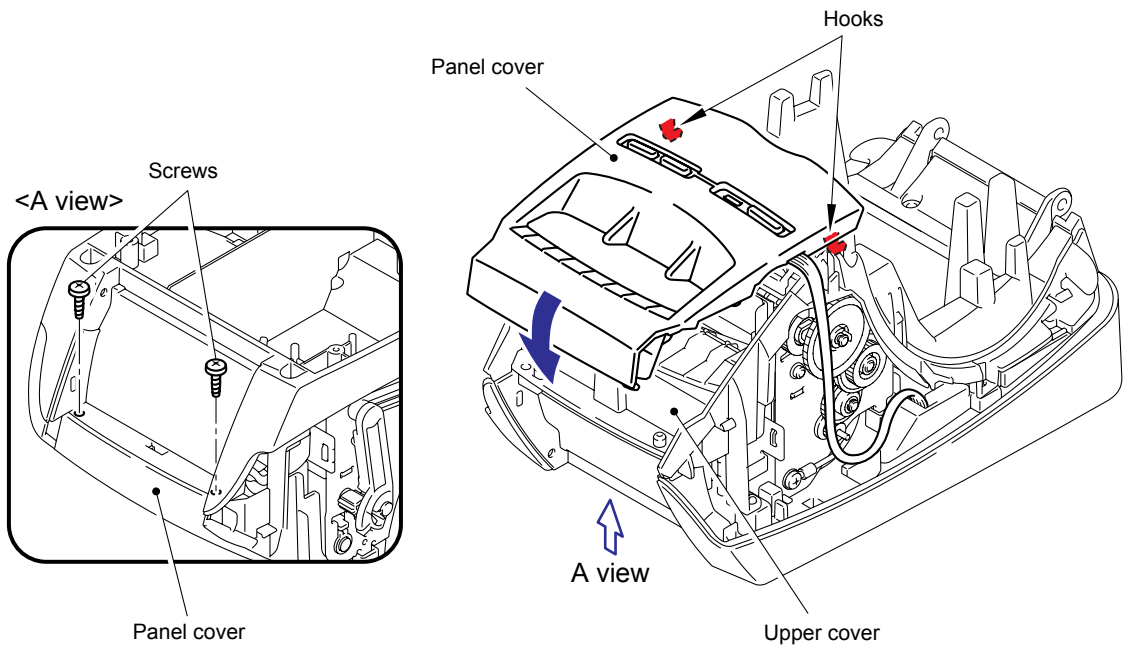

**Fig.3.2-24 Installing the Panel Cover (5)**

- (7) Route the SB PCB harness on the upper cover as shown in the figure.

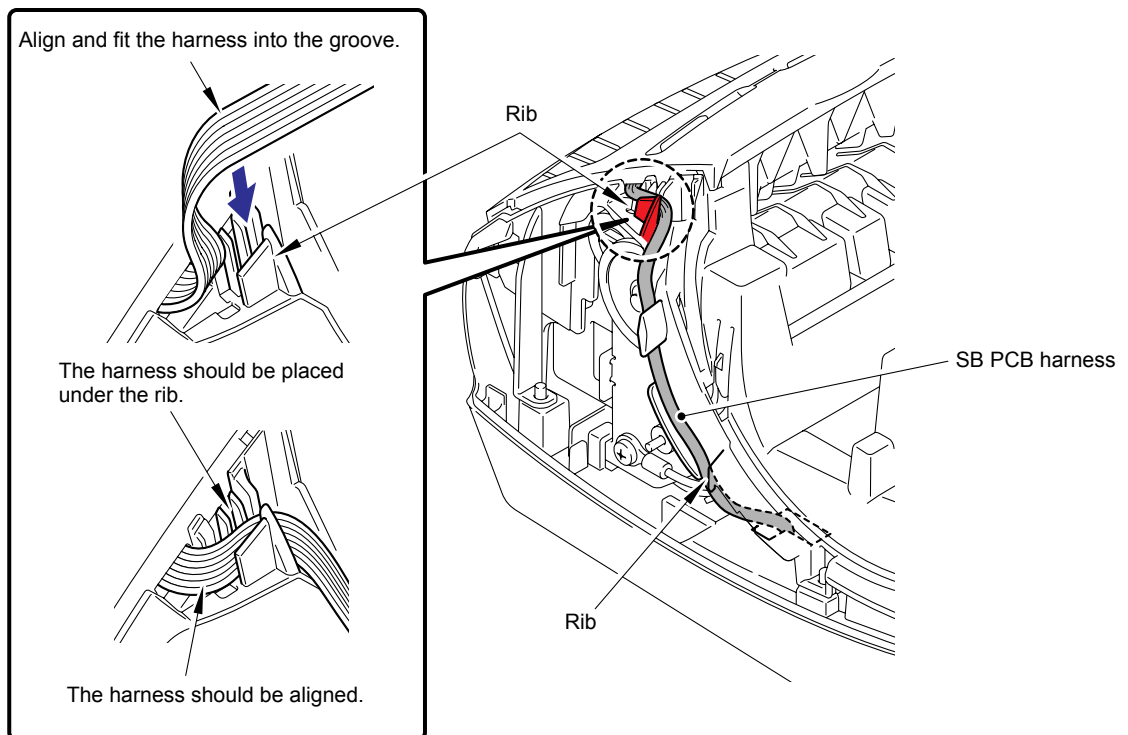

**Fig.3.2-25 Installing the Panel Cover (6)**

**[ 6 ] Installing the Side Cover L, R**

- (1) Catch the three hooks A of the side cover L with the under cover.
- (2) Catch the four hooks B of the side cover L with the upper cover, and assemble it.

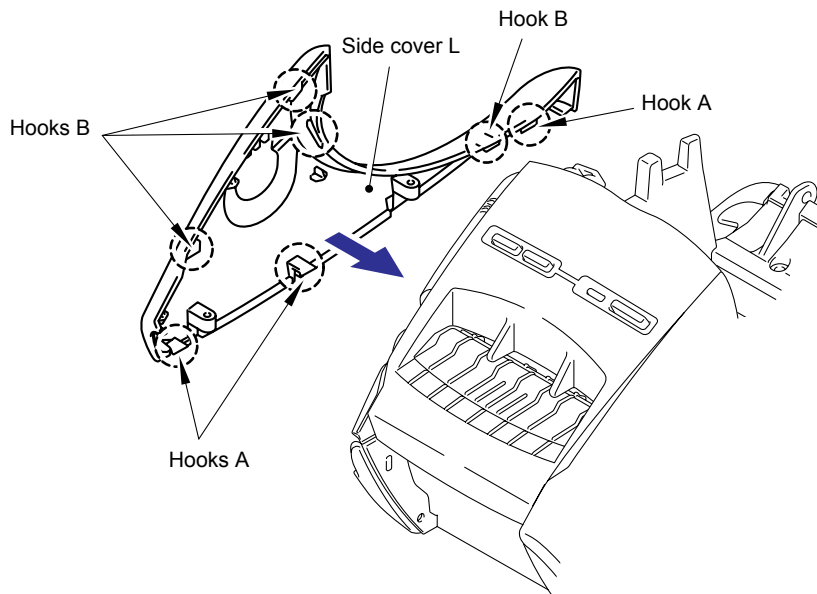

**Fig.3.2-26 Installing the Side Cover L, R (1)**

- (3) Turn the machine upside down, and secure the side cover L with the two screws.

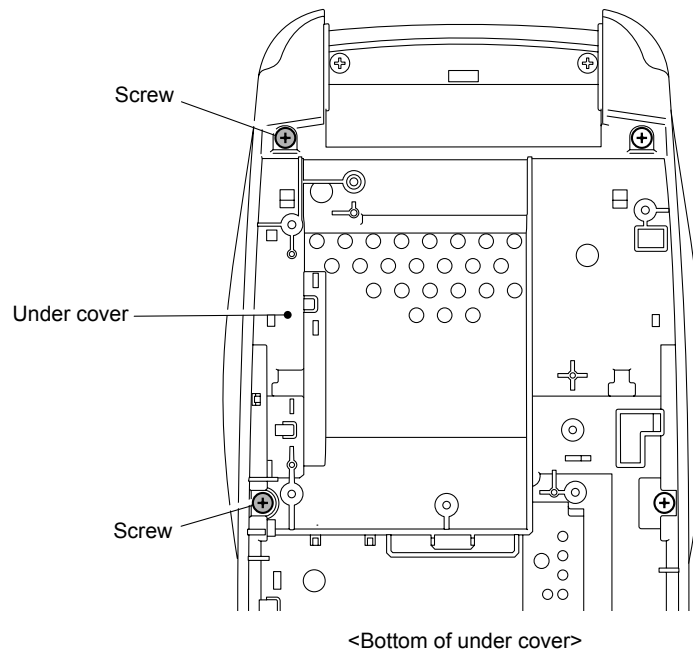

**Fig.3.2-27 Installing the Side Cover L, R (2)**

- (4) Catch the three hooks C of the side cover R with the under cover.
- (5) Catch the four hooks D of the side cover R with the upper cover, and assemble it.

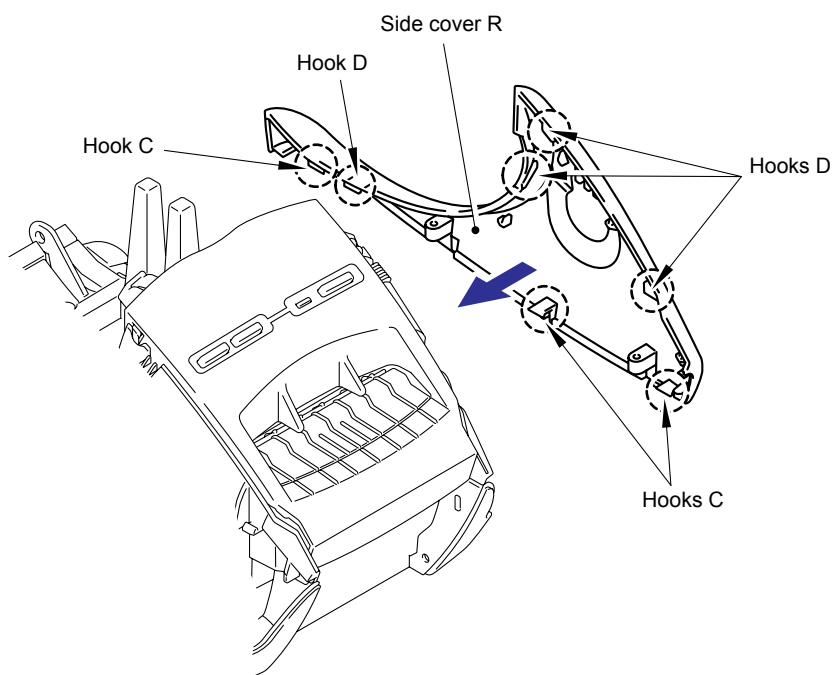

**Fig.3.2-28 Installing the Side Cover L, R (3)**

- (6) Turn the machine upside down, and secure the side cover R with the two screws.

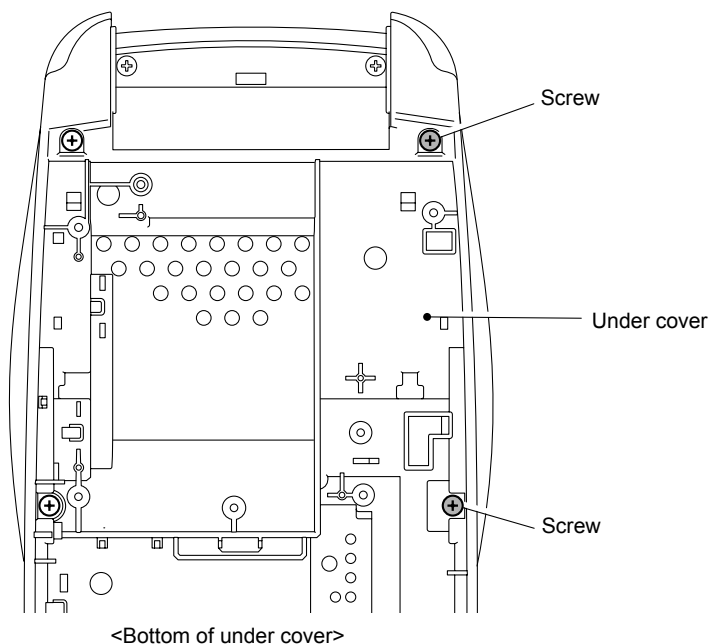

**Fig.3.2-29 Installing the Side Cover L, R (4)**

## [ 7 ] Installing the Media PCB ASSY

- (1) Assemble the media PCB ASSY with the two screws.

**Important:** When replacing the media PCB ASSY, and then check the items using the “MAINTENANCE SOFTWARE OPERATION” in APPENDIX 1.

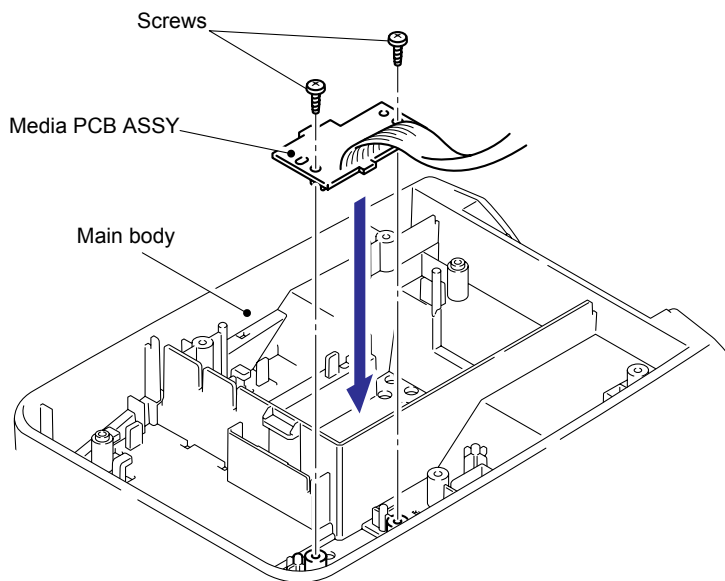

Fig.3.2-30 Installing the Media PCB ASSY

## [ 8 ] Installing the Sub ASSY Inlet

- (1) Put the harnesses of the sub ASSY inlet through the holes on the under cover.
- (2) Insert the sub ASSY inlet to the hole of the under cover and put it until its hooks are properly hooked.

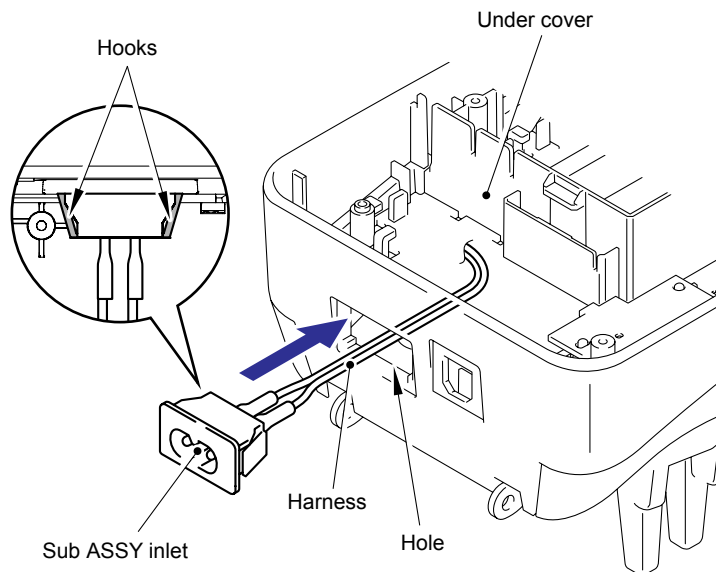
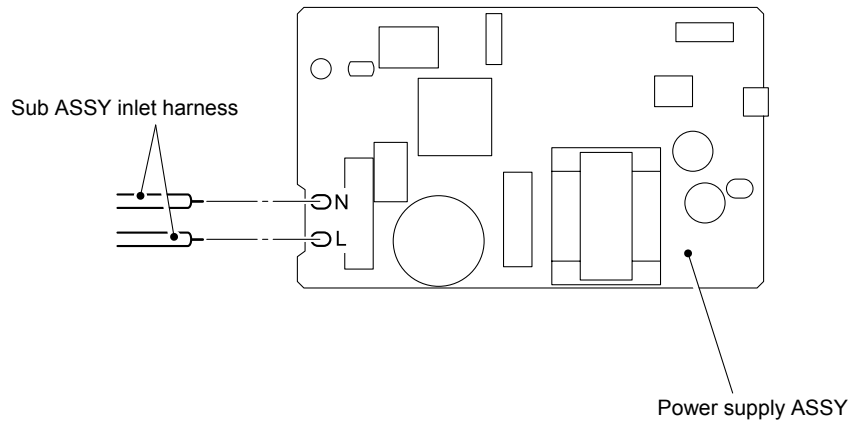

Fig.3.2-31 Installing the Sub ASSY Inlet (1)

- (3) Solder the harnesses of the sub ASSY inlet to the power supply ASSY as shown in the figure.



**Fig.3.2-32 Installing the Sub ASSY Inlet (2)**

- (4) Route the harness of the sub ASSY inlet as shown in the figure.

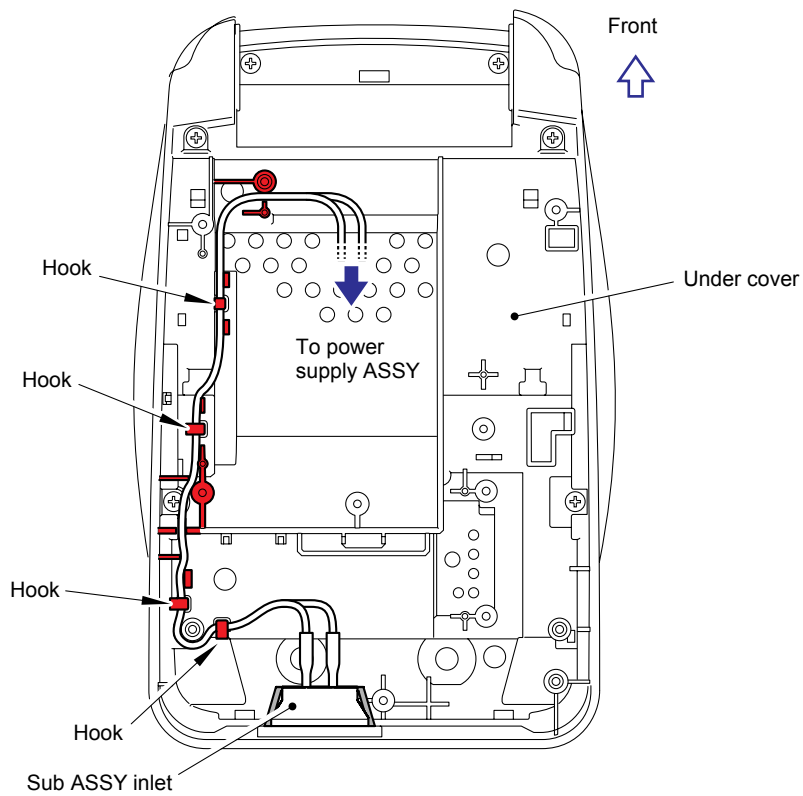

**Fig.3.2-33 Installing the Sub ASSY Inlet (3)**

**[ 9 ] Installing the Power supply ASSY and Main PCB ASSY**

- (1) Attach the insulating sheet S onto the under cover as shown in the figure below.

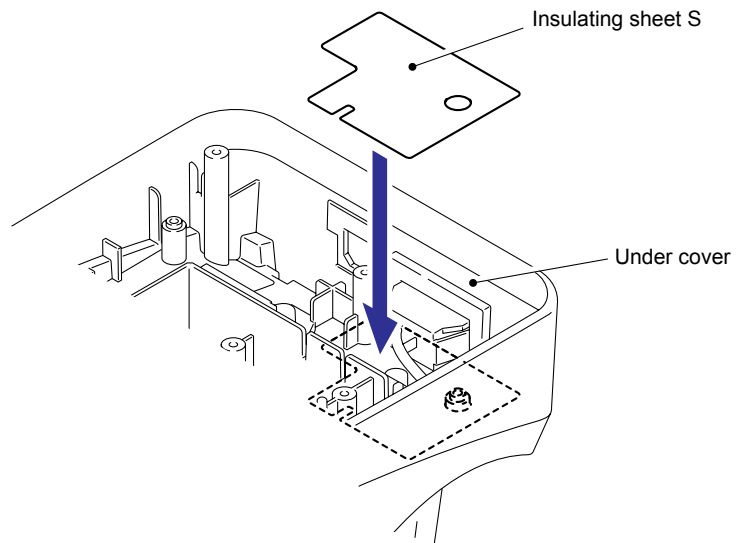

**Fig.3.2-34 Installing the Power supply ASSY and Main PCB ASSY (1)**

- (2) Assemble the ground spring plate, FG harness ASSY and main PCB ASSY with the three screws.

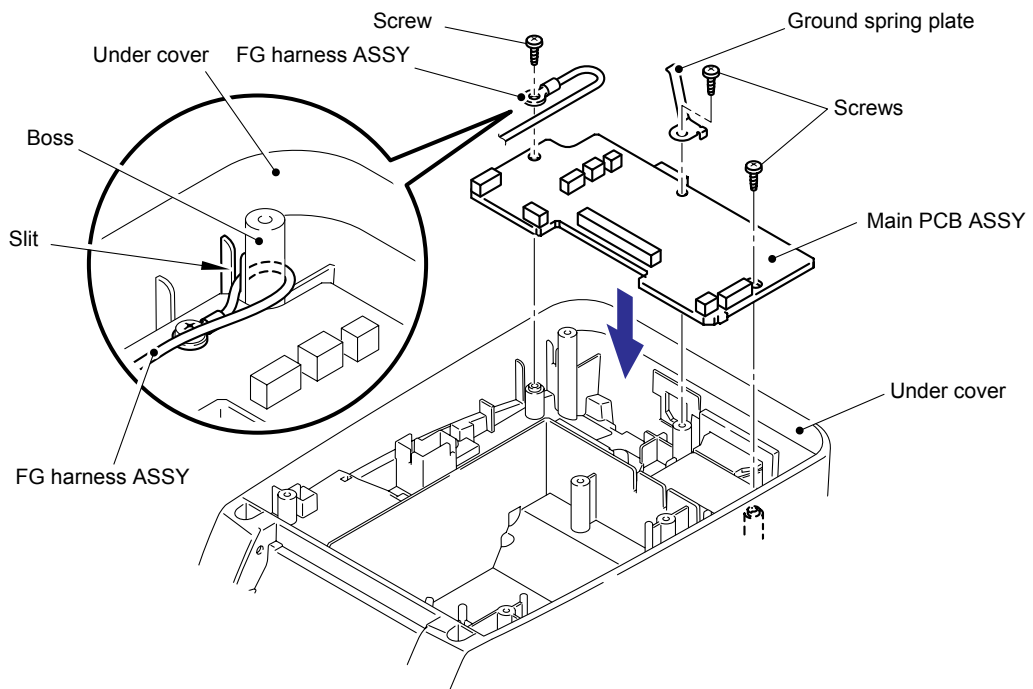

**Fig.3.2-35 Installing the Power supply ASSY and Main PCB ASSY (2)**

- (3) Connect the power8 harness ASSY into the power supply ASSY.

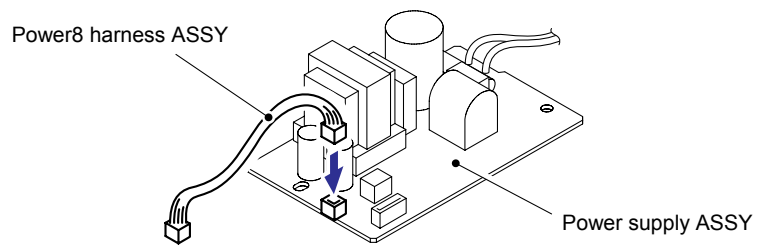

**Fig.3.2-36 Installing the Power supply ASSY and Main PCB ASSY (3)**

- (4) Connect the power8 harness ASSY into the main PCB ASSY.  
(5) Connect the main PCB harness into the power supply ASSY.

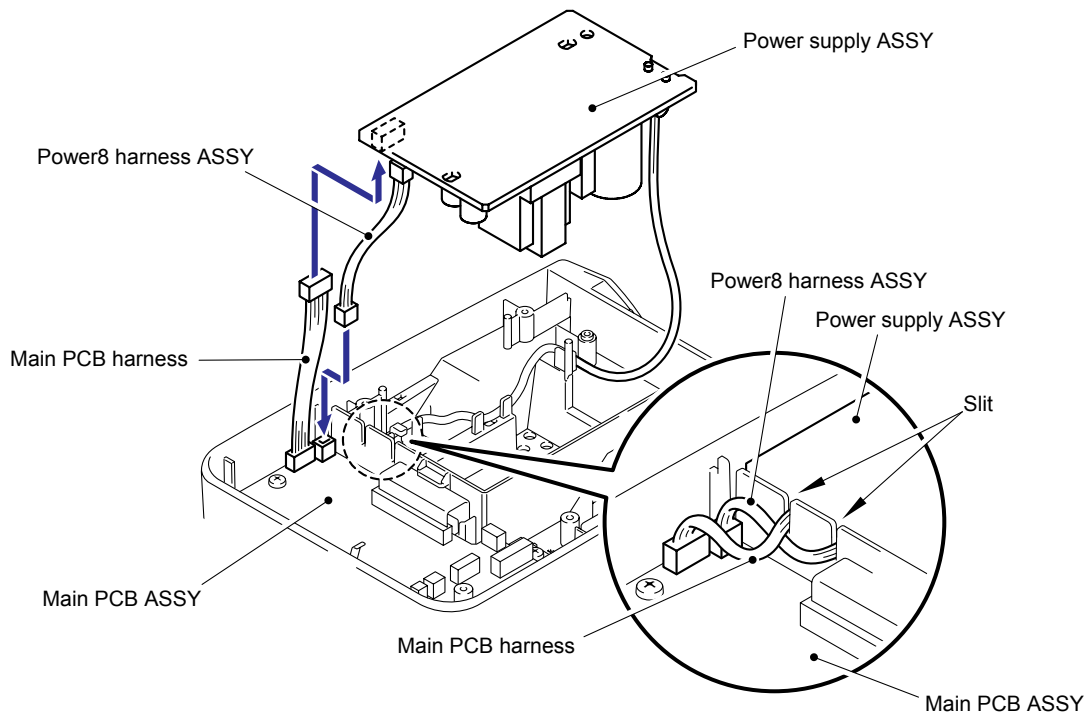
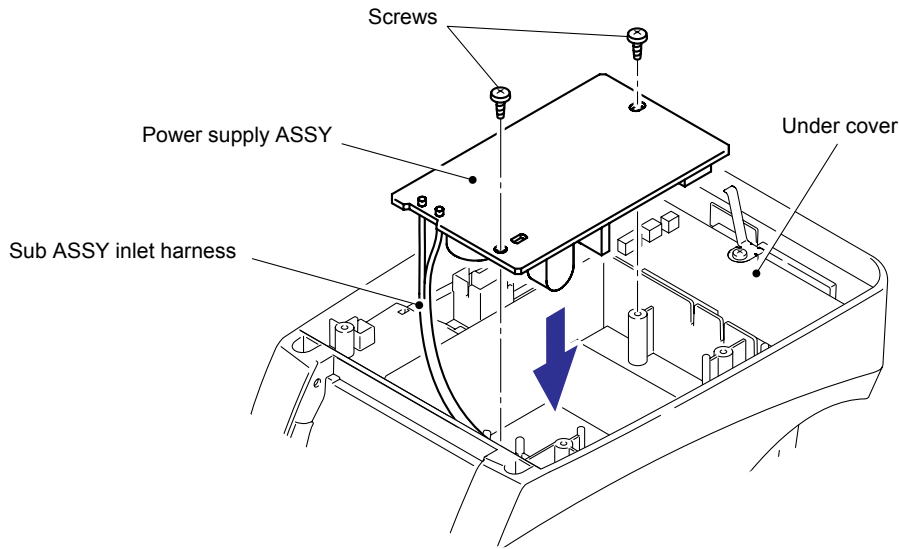

**Fig.3.2-37 Installing the Power supply ASSY and Main PCB ASSY (4)**



- (6) Assemble the power supply ASSY onto the under cover with the two screws.

*Note: Confirm that the sub ASSY inlet harness is not pinched.*



**Fig.3.2-38 Installing the Power supply ASSY and Main PCB ASSY (5)**

- (7) Connect the five connectors (CN5, CN7, CN8, CN10, CN11) and two flat cables (CN3, CN4) into the main PCB ASSY.

**Important: When replacing the main PCB ASSY, and then check the items using the "MAINTENANCE SOFTWARE OPERATION" in APPENDIX 1.**

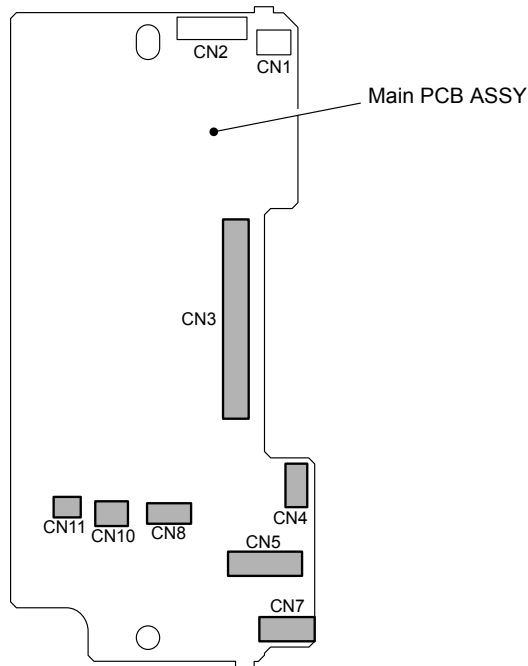

**Fig.3.2-39 Installing the Power supply ASSY and Main PCB ASSY (6)**

- (8) Route the harnesses of CN8, CN10, CN11 and FG harness as shown in the figure.
- (9) Secure the harness of CN11 with the filament tape.

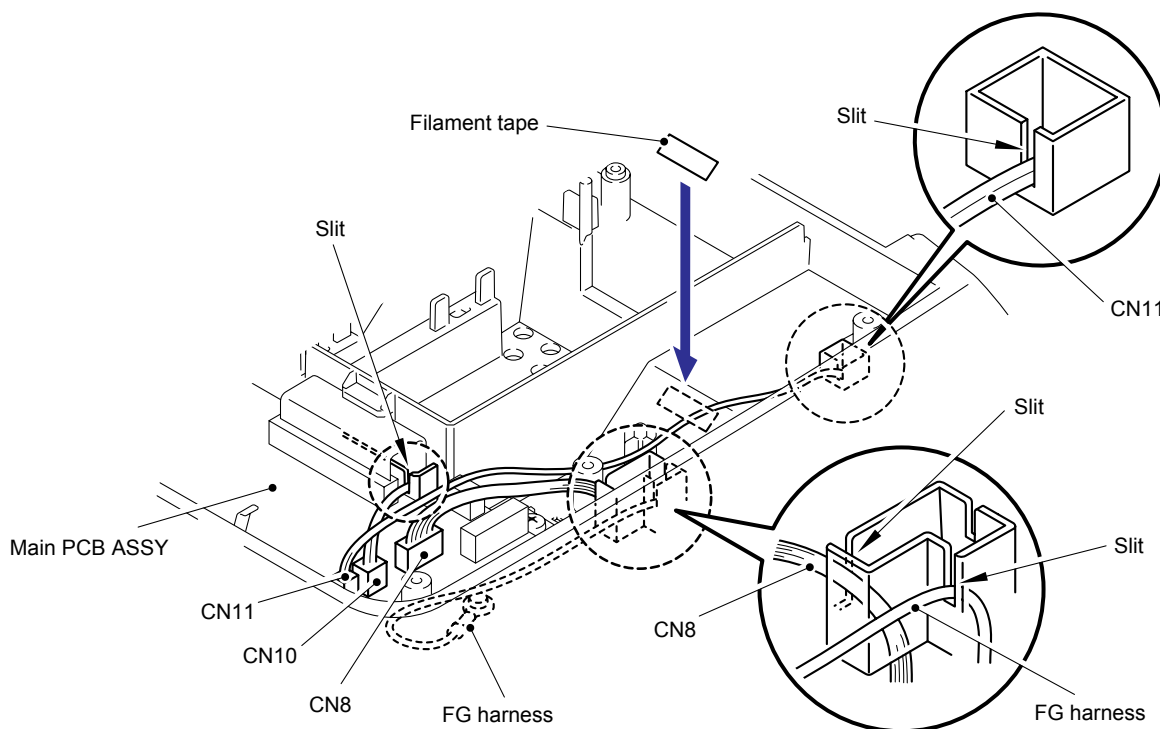

**Fig.3.2-40 Installing the Power supply ASSY and Main PCB ASSY (7)**

- (10) Assemble the lower plate ASSY onto the main body with the four screws.

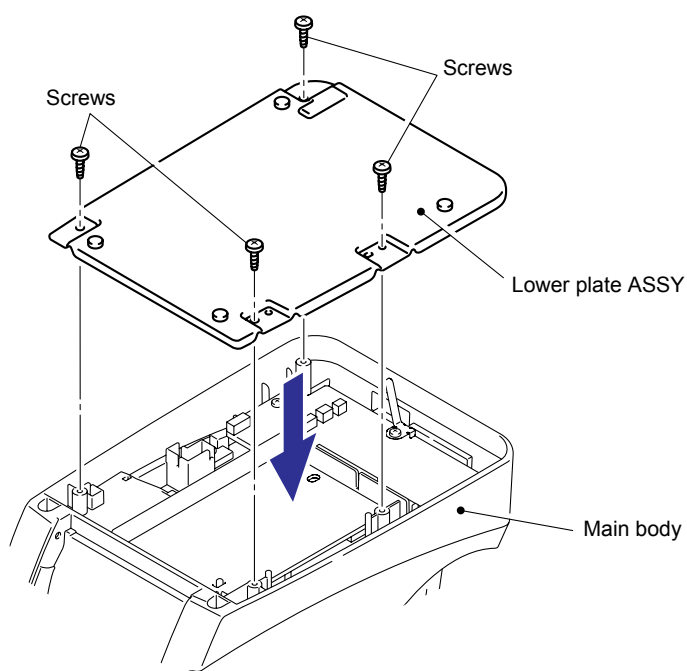

**Fig.3.2-41 Installing the Power supply ASSY and Main PCB ASSY (8)**

**[ 10 ] Installing the Front Cover and Tray S**

- (1) Assemble the tray S onto the front cover.

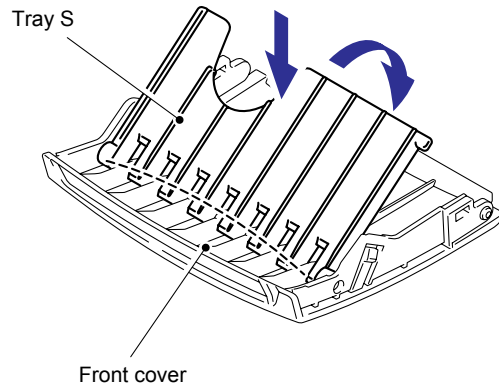

**Fig.3.2-42 Installing the Front Cover and Tray S (1)**

- (2) Assemble front cover onto the main body.
- (3) Close the front cover.

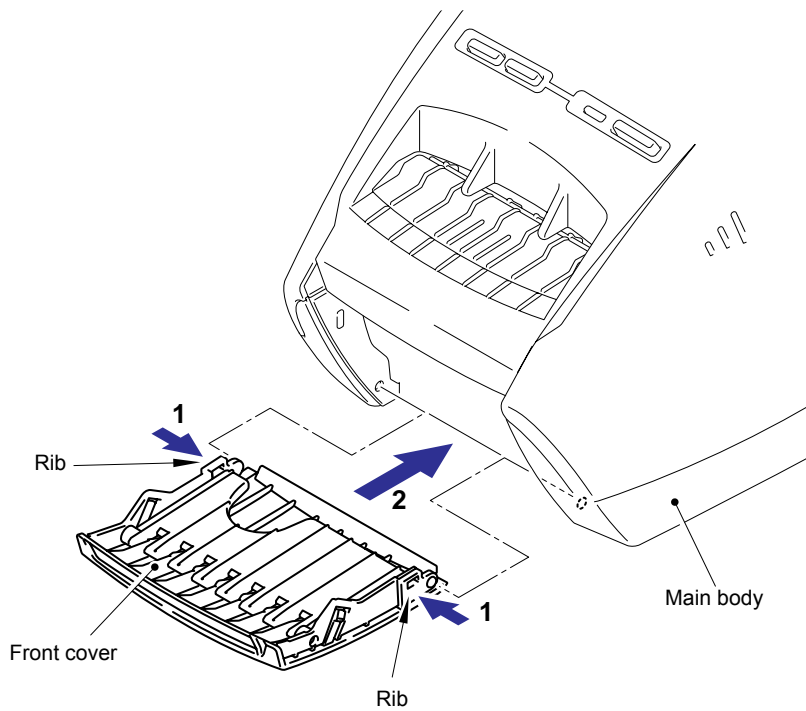

**Fig.3.2-43 Installing the Front Cover and Tray S (2)**

**[ 11 ] Installing the Top Cover and Thermal Tape**

- (1) Insert one of the two bosses of the top cover into the corresponding rib hole of the upper cover, and then insert the other boss to the rib hole by bending the rib.

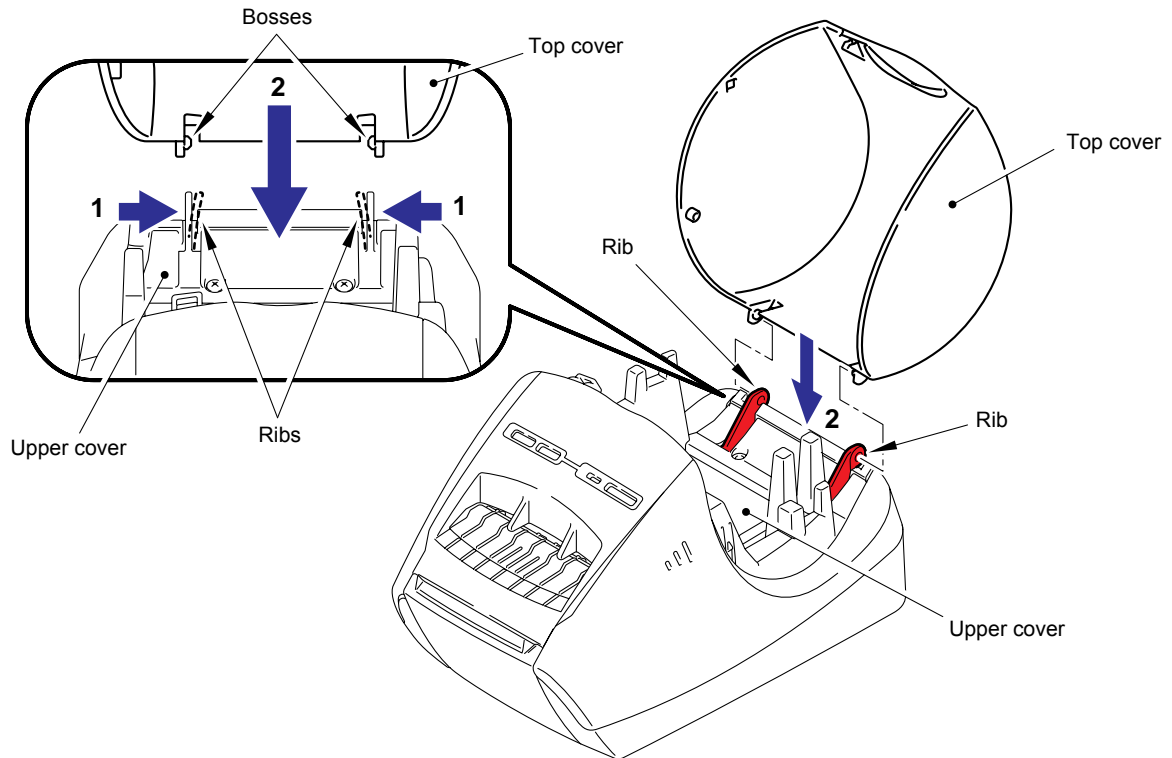

**Fig.3.2-44 Installing the Top Cover and Thermal Tape (1)**

- (2) Assemble Link lever onto the top cover.

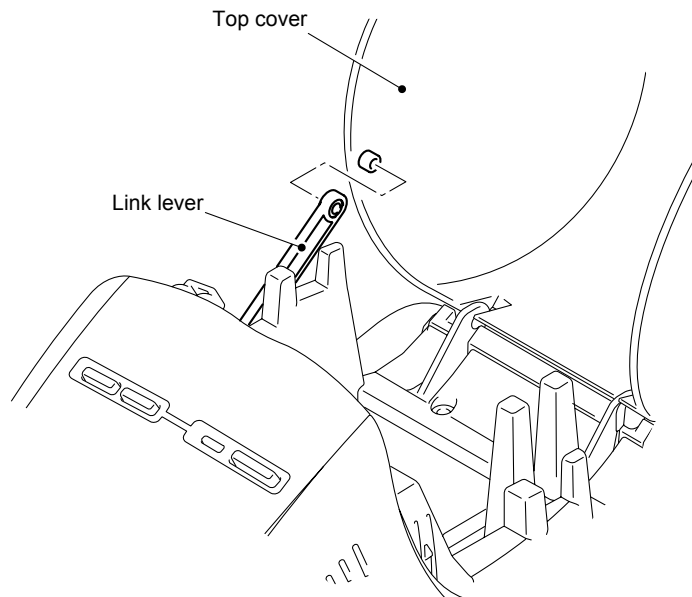

**Fig.3.2-45 Installing the Top Cover and Thermal Tape (2)**

- (3) Assemble the thermal tape onto the main body.
- (4) Close the top cover.

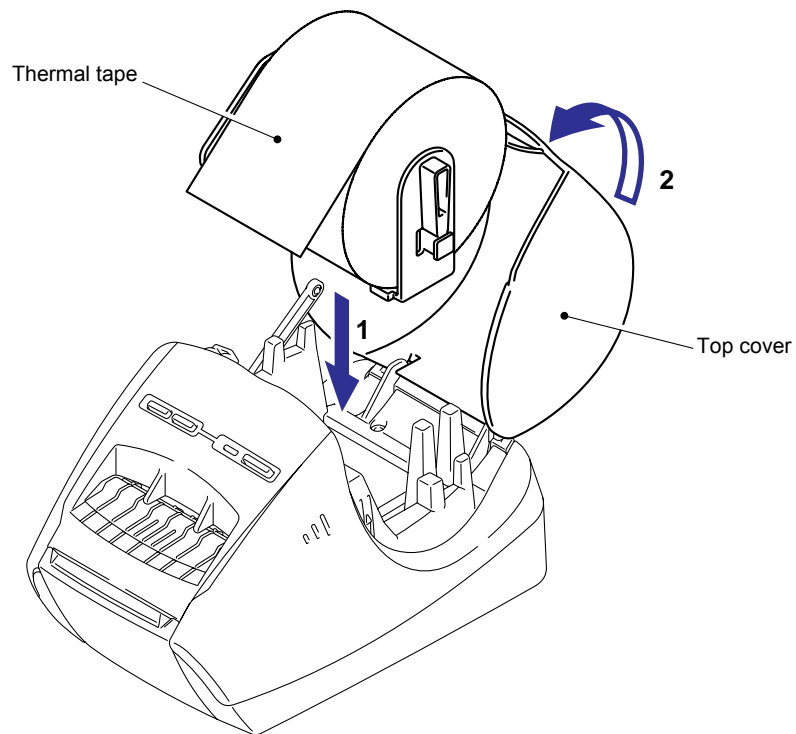

**Fig.3.2-46 Installing the Top Cover and Thermal Tape (3)**

## [ 12 ] Demonstration Print and Final Check

- (1) Insert the AC cord into a outlet.
- (2) Set the tape with the maximum width (62mm), and press the Feed button six times in a row while pressing the ON/OFF button when the power is OFF. Then, leave your fingers from the both buttons, and 100mm full-width gray print is performed. This print operation is repeated until the power is turned OFF.

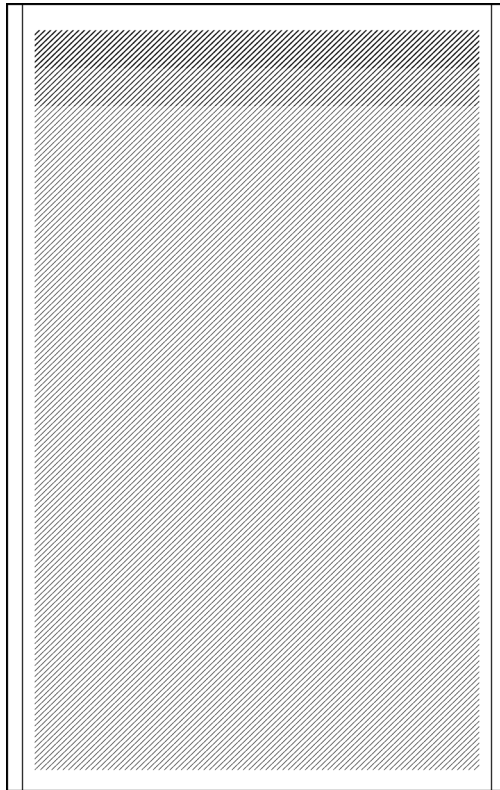

< Print sample >

- (3) Confirm that the tape is sent properly, print is correct, and the tape is cut properly during the demonstration print. If you find any problems, consult "CHAPTER IV TROUGLESHOOTING AND ERROR MESSAGE."
- (4) Open the top cover and confirm that the head ASSY is released from the platen ASSY.
- (5) Confirm that the Feed/Cut button works properly.
- (6) Confirm that the ON/OFF button works properly.

## **CHAPTER IV TROUBLESHOOTING AND ERROR MESSAGE**

This section gives the service personnel some of the troubleshooting procedures to be followed if an error or malfunction occurs with this machine.

It is impossible to anticipate all of the possible troubles which may occur in the future and determine the troubleshooting procedures, so this chapter covers some sample troubles.

However, these samples will help service personnel pinpoint and repair other defective elements if he/she analyzes and examines them well.

### **4.1 PRECAUTIONS**

Be sure to observe the following precautions to prevent secondary problems from happening during troubleshooting.

- (1) Make sure to unplug an AC cord to ensure no power supply, when doing a conductivity test with a tester.
- (2) When a printing error occurs, pull out the thermal head cable from the connector until the peripheral circuit related to the thermal head works properly.





### **4.2 AFTER REPAIRING**

Verify again that the repaired portion works properly. Then adjust and examine this machine according to "APPENDIX 1. MAINTENANCE SOFTWARE OPERATION". It is recommended to record and store actual troubleshooting and repair procedures to accumulate repair know-how.

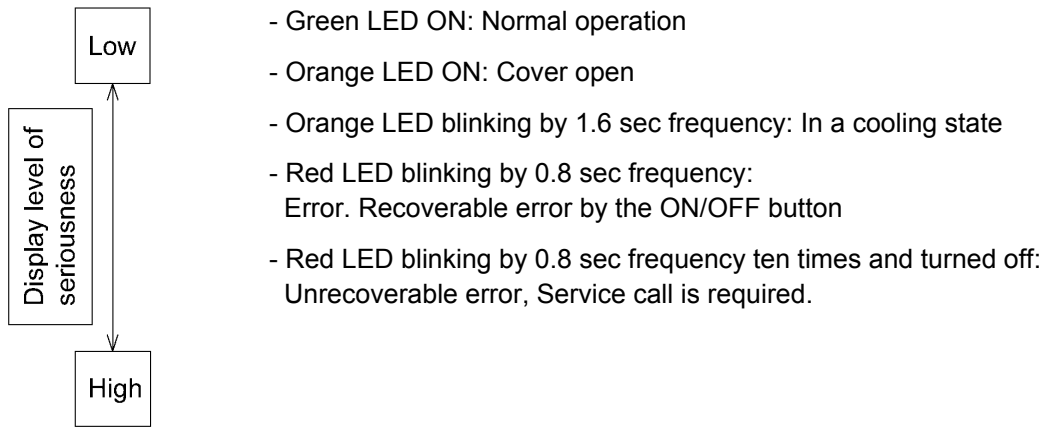
### 4.3 LED CONTROL IN DIFFERENT SITUATIONS AND MEASURE AGAINST ERRORS

The display priority is specified as follows.









LED	State
Turned off 	Power OFF
Green LED ON 	Power ON
Orange LED ON 	Cover open (While the machine is not running)
Low rate blinking (1.6 sec frequency)  LED OFF for 0.8 sec      Orange LED ON for 0.8 sec	In a cooling state
Fast blinking (0.8-sec cycle)  LED OFF for 0.4 sec    Red LED ON for 0.4 sec    LED OFF for 0.4 sec    Red LED ON for 0.4 sec	Error <ul style="list-style-type: none"> <li>- Cutter error</li> <li>- Media mark detect error <ul style="list-style-type: none"> <li>Tape mounting error</li> <li>End of tape</li> <li>Tape jam</li> </ul> </li> <li>- Media mismatch or no media</li> <li>- Communication error</li> <li>- System error (After the LED blinking fast ten times, it is turned OFF.)</li> <li>- Cover open (while the machine is running)</li> </ul>



## 4.4 ERROR MESSAGE

A list of the error messages that are indicated on the printer monitor is shown below:

Error Messages	Advices
No Errors.	None.
A roll of labels or tape is not installed.	Install into the P-touch the roll of labels or tape indicated on the monitor.
End of tape.	Set a new roll into the P-touch and then click  on the monitor.
Buffer full error in P-touch.	Turn the P-touch off and then on. Click  on the monitor.
P-touch tape cutter is not operating.	(1) Before removing any jammed labels, turn off the P-touch. (2) After removing jammed labels, retry the print. Be careful not to injure your hands, etc. with the tape cutter.
Cannot change the roll of labels or tape while printing.	Turn the P-touch off and then on. Click  on the monitor.
The roll of labels or tape inside the machine does not match the one selected in the application. Click [Details...] for further assistance.	Install the correct roll of labels or tape into the machine and then click  on the monitor.  Click  to cancel the print job. Go to the Page Properties in the P-touch Editor and change the selection of the supply roll so that it matches the one inside the machine. Try printing the label again.
P-touch may have invalid data in memory.	Turn the P-touch off and then on.
Cover open.	Close the cover.
Connected P-touch is not QL-570.	Change the model to the correct one.
Tape cannot be fed. (There may be no more tape.) Press [Details...] for further assistance.	First check that the tape is not empty. <If the taper is empty> Install a new roll of labels or tape into the P-touch, and then click  on the monitor. <If the tape is not empty> Check the tape to ensure it is loaded correctly. Make sure that the label path is not blocked. Then click  on the monitor.
Communication error between PC and P-touch.	(1) Check that the P-touch is connected to your computer with the USB interface cable (that comes with the P-touch). Also check the cable for weak connection. (2) Make sure that the P-touch is turned on. If any communications error has occurred, turn the P-touch off and then on.

Error Messages	Advices
Not enough memory to print document.	Wait until any other application(s) is finished and then try to print again.
Not enough disk space to spool document.	Ensure sufficient disk space.
The cooling operation is underway. Wait for a while.	The cooling operation is underway. Wait for a while.
Sending...	Print data is being sent. Please wait.
Printing...	Printing. Please wait.
Error of unknown cause occurred.	Turn off and on the power of the printer main unit. If the error is not resolved, it needs repairs.

A list of the error messages that are indicated while the service person tool is being used is shown below.

Check Item	Error	Error Messages	Advices
Write default EEPROM data(0)	Communication error	Cannot transmit.	Check the power supply and the USB connector.
	Write error	Failed to write the default settings.	Check the power supply and the USB connector.
Media&cover sensors check(2)	Communication error	Cannot transmit.	Check the power supply and the USB connector.
	Check failure	The sensor check failed.	Check if any obstacle is placed around the media sensors.
Cut test(3)	Communication error	Cannot transmit.	Check the power supply and the USB connector.
	Check failure	The Cut test failed.	Check if any obstacle is placed around the cutter and the delivery opening.
Temperature check(4)	Communication error	Cannot transmit.	Check the power supply and the USB connector.
Write serial number(8)	Communication error	Cannot transmit.	Check the power supply and the USB connector.
	Check failure	Failed to write the serial number	Check the power supply and the USB connector.

## 4.5 TROUBLESHOOTING FLOWS

[ 1 ] Printing is performed with specific dots omitted.

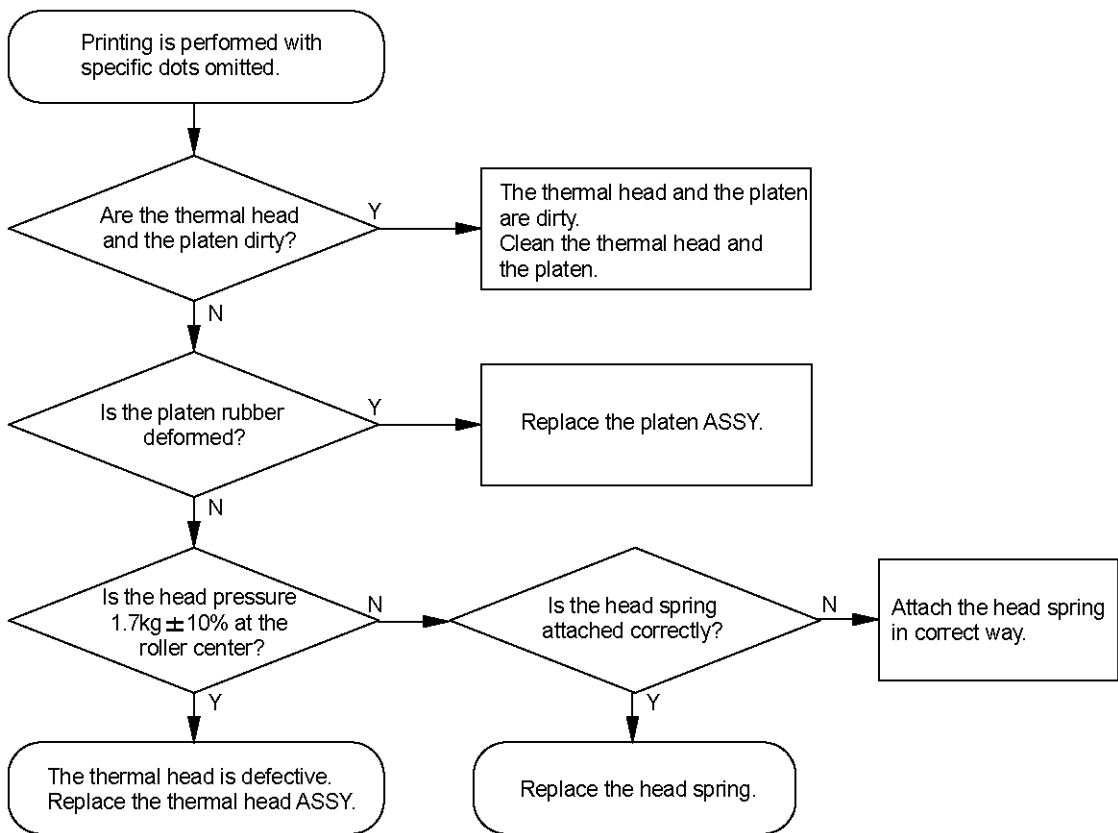

[2] The tape is not detected correctly.

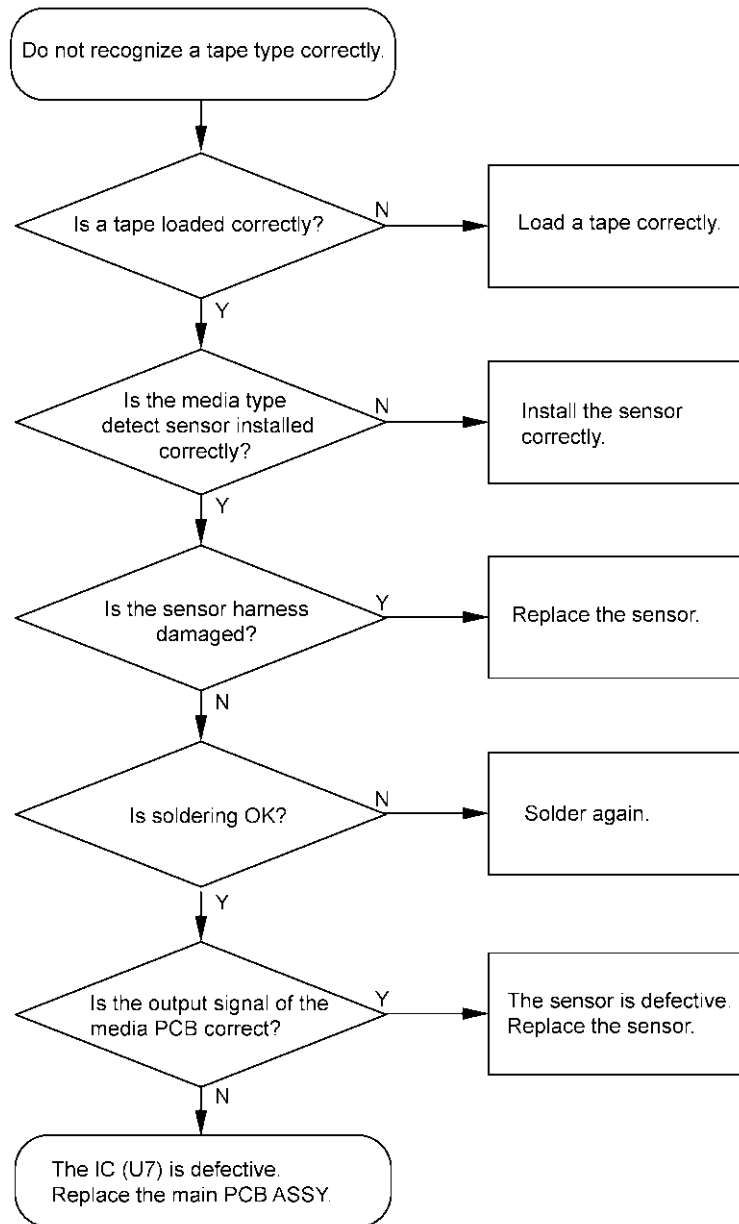

[3] LED does not turn on.

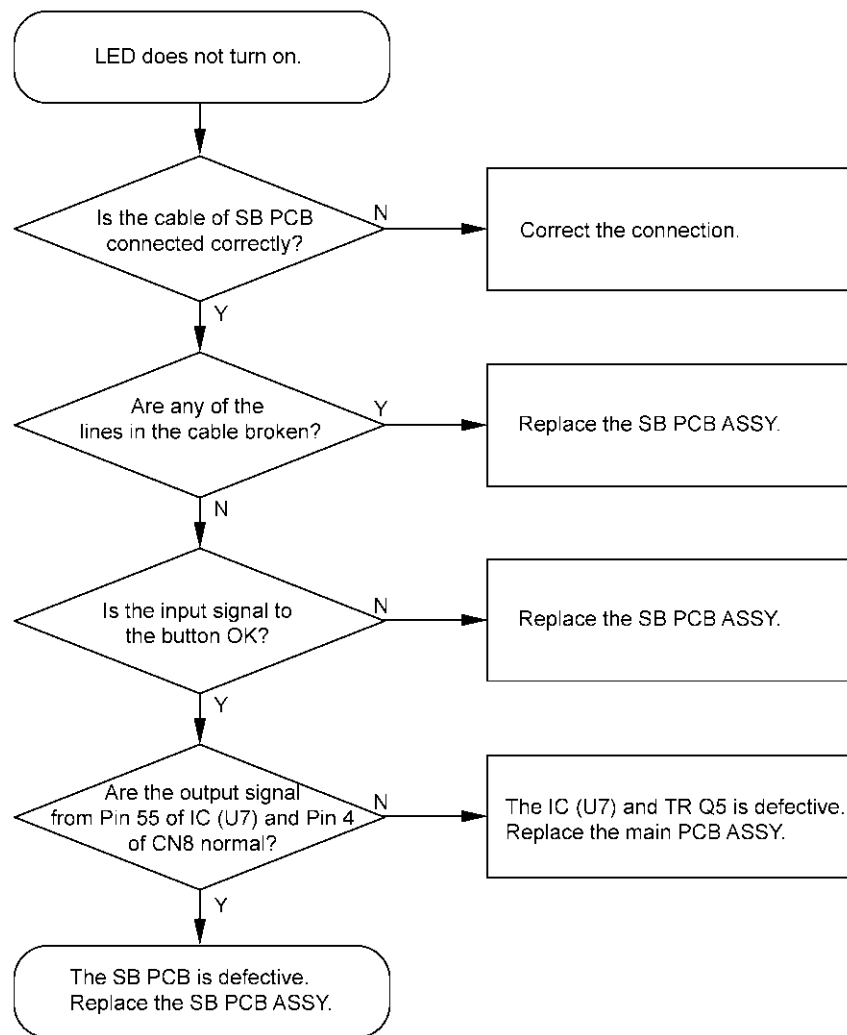

[4] No printing is performed.

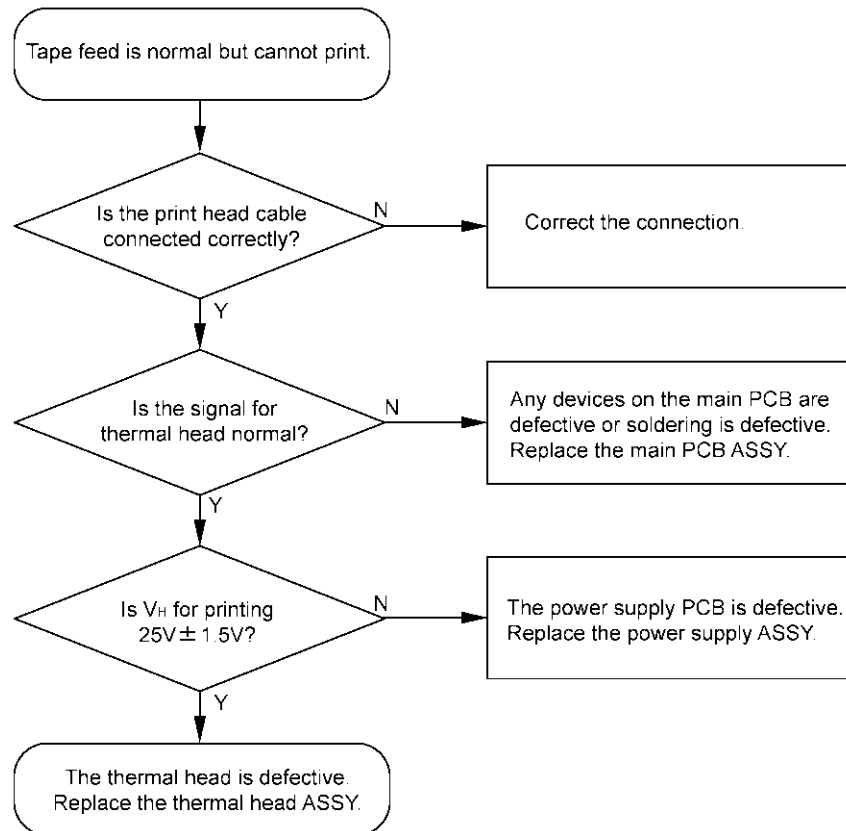

[5] The interface malfunction.

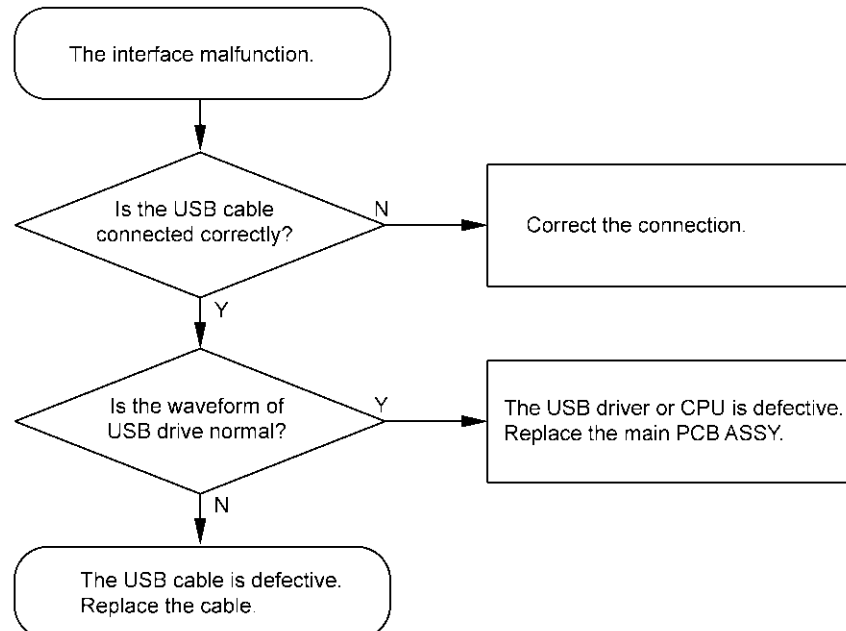

[6] The tape is not cut.

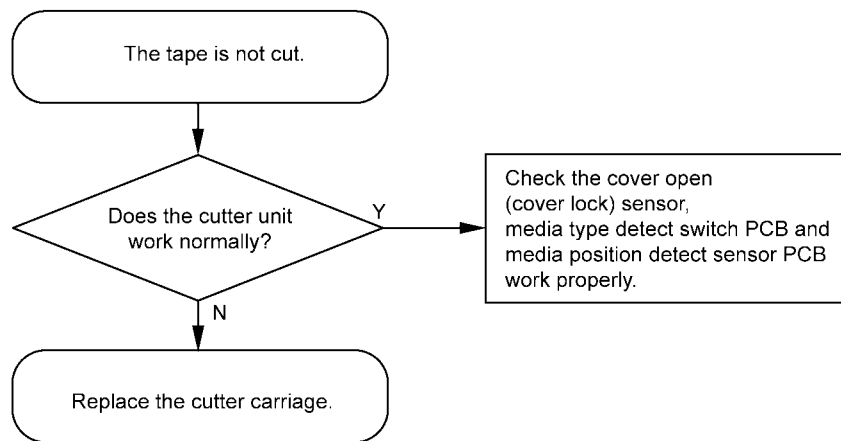



[ 7 ] The tape is not fed correctly.



## APPENDIX 1. MAINTENANCE SOFTWARE OPERATION

This software has the feature to adjust and examine every component mounted on a mechanical component or the main PCB ASSY when it is replaced, and the capability to write the information such as the model name and serial number into the EEPROM mounted on the main PCB ASSY.

(Supported OS: Windows® 2000, Windows® XP, Windows® 7)

**Important: The maintenance software includes four types of the software, which is distinguished generally.**

- Reset software tool (ql500tstReset.exe)
- Maintenance software tool (ql570tstSE.exe)
- VR adjustment tool (ql500tstVRAdjust.exe)
- Auto power-off setting tool (autopoff.exe)

### <Purpose and flow chart of each tool>

- 1.1 Reset software tool Always implement this software before the inspections in the maintenance software when the main PCB ASSY, tape sensor PCB ASSY, power supply ASSY, head ASSY is replaced.

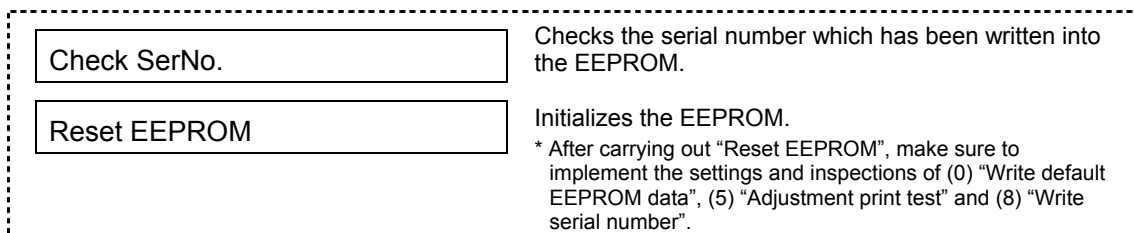

- 1.2 Maintenance software tool Implement the applicable setting and inspection.

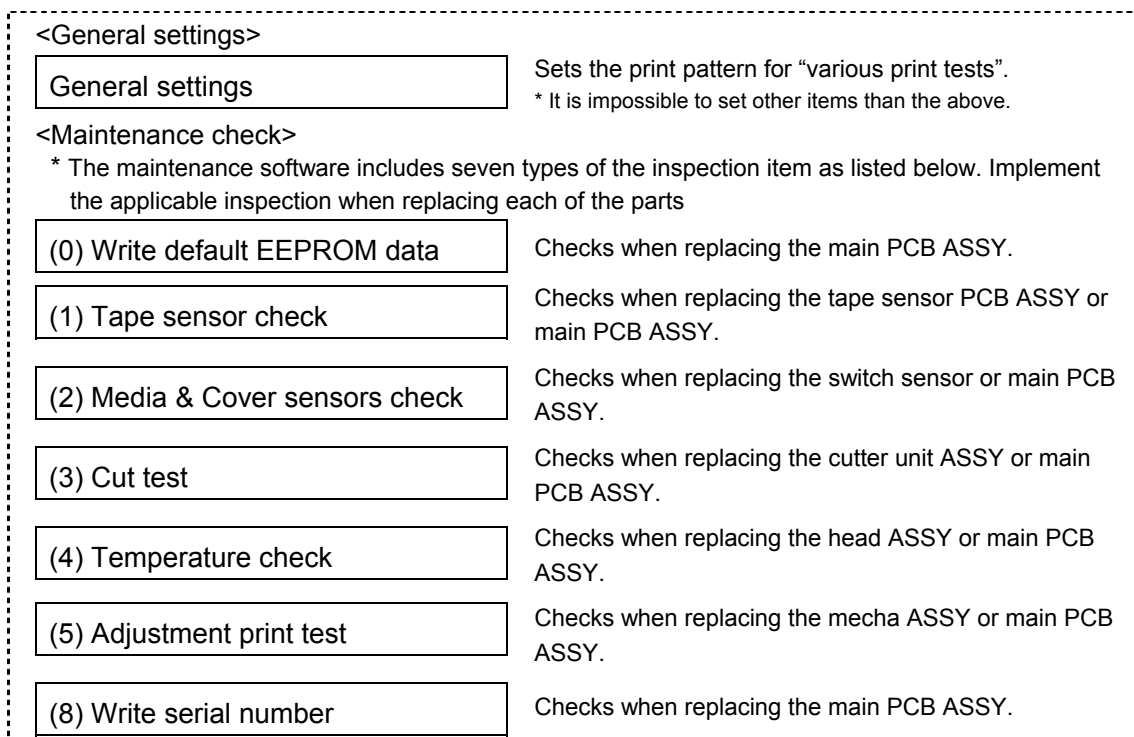

- 1.3 VR adjustment tool If "Tape sensor check" in the maintenance software tool fails, this adjustment must be performed whenever any of the main PCB ASSY, media PCB ASSY, or tape sensor PCB ASSY is replaced.



1.4 Auto power-off setting tool

This tool is used to set the correct auto power-off time for models to particular destinations and with particular main PCB.

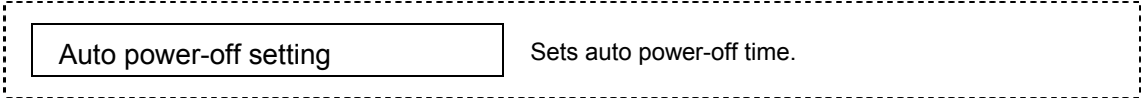

## APPENDIX 1.1 Purpose and Use Procedure of the Reset Software Tool (ql500tstReset.exe)

*Note: Be sure to reset the EEPROM before making an examination after repair work is done.*

This tool serves to reset the EEPROM.

<Operating Procedure>

- (1) Start the reset software. (File name: ql500tstReset.exe)  
The following screen appears. (Fig. 1)
- (2) Connect the machine to your PC with the USB cable and turn the ON/OFF button ON.

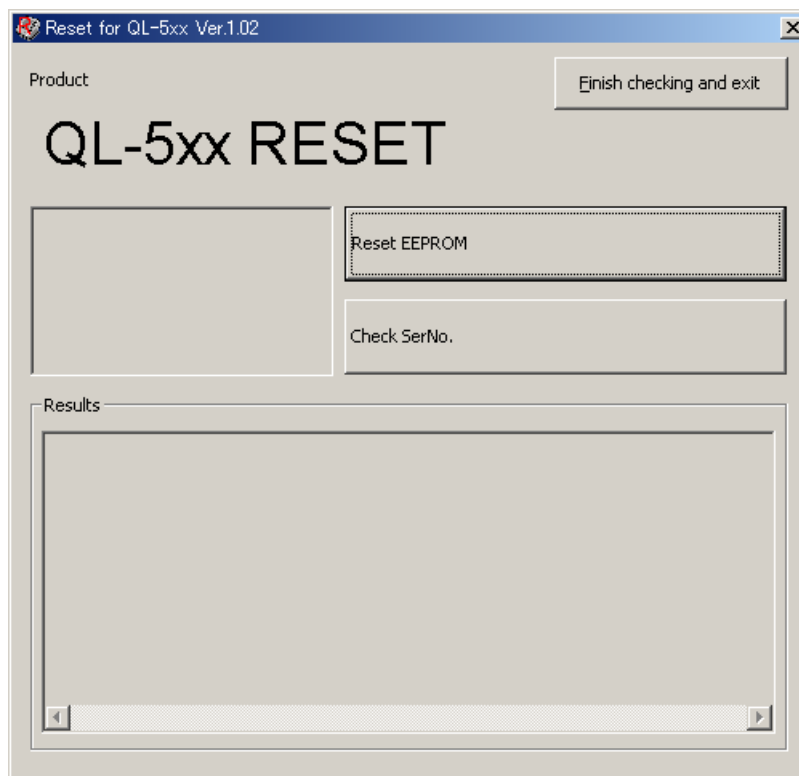

Fig. 1

*Note: When new hardware is detected and the "New hardware detection wizard" screen appears, press the [Cancel] button.*

- (3) Press the [Check SerNo.] button, and “NG” is displayed as the check result, and the present serial No. is displayed in the “Results” column.

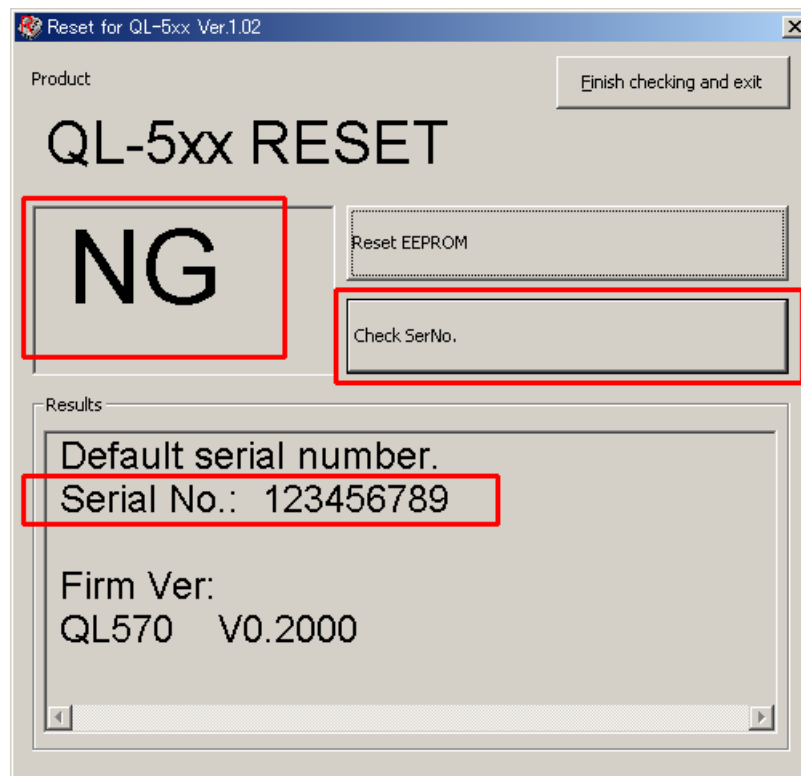

Fig. 2

- (4) Press the [Reset EEPROM] button to reset the EEPROM of the main unit to the initial state (factory default). “Reset command OK” is displayed in the “Results” column.

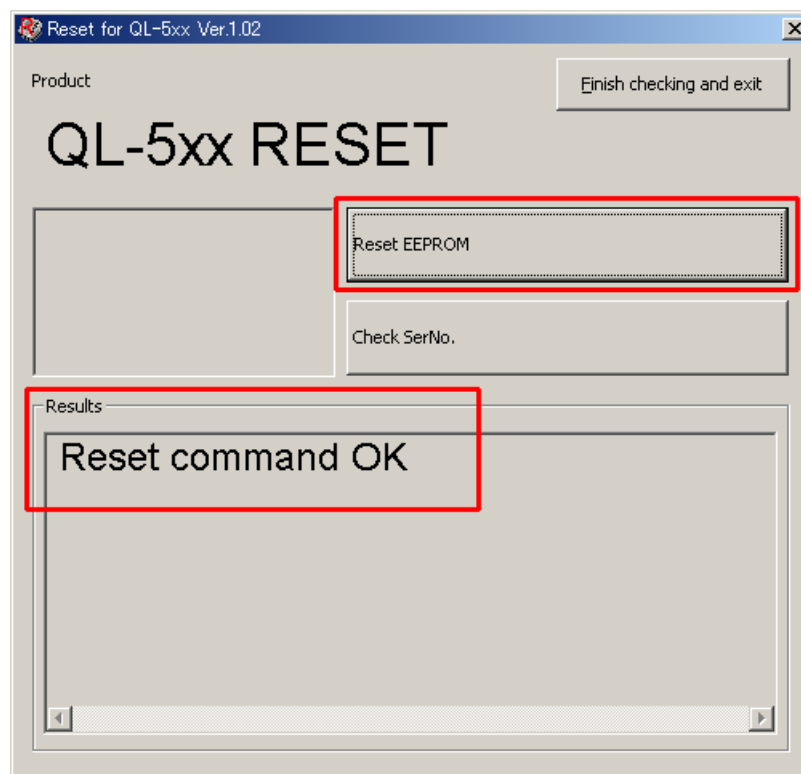

Fig. 3

- (5) Turn OFF the power of the main unit, and then turn it ON again.
- (6) Press the [Check SerNo.] button. If “OK” is displayed as the check result, and if the serial No. displayed in the “Results” column is “B00000001”, the reset operation is complete.

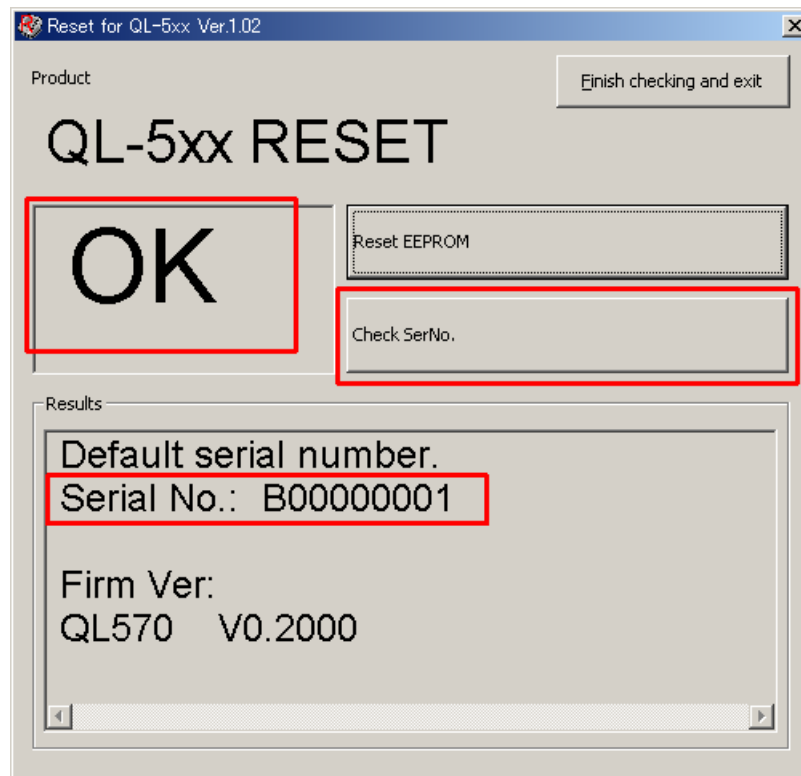

Fig. 4

## APPENDIX 1.2 Setting and Use Procedures of the Maintenance Software Tool (ql570tstSE.exe)

### [ 1 ] Setting Procedure of Maintenance Software

(1) Start the maintenance software. (File name: ql570tstSE.exe)

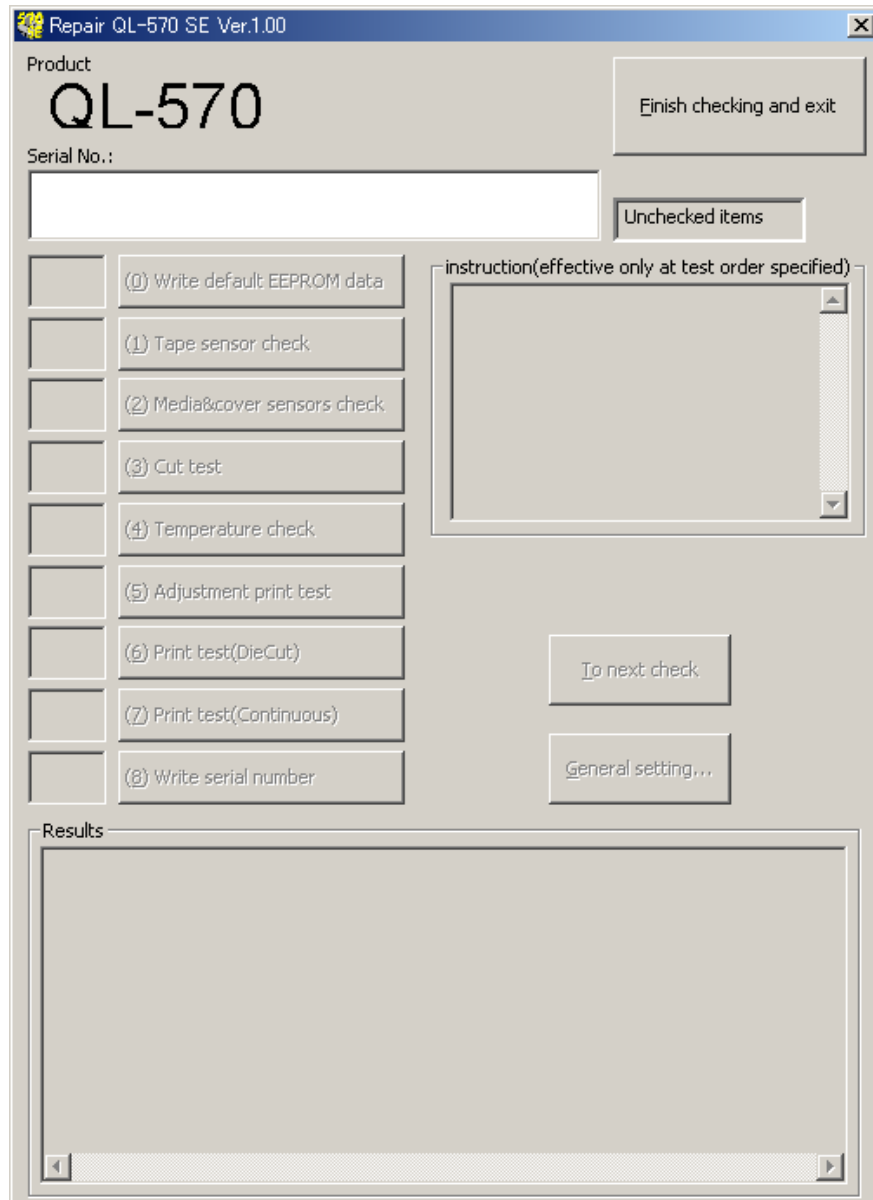

Fig. 5

(2) Connect the machine to your PC with the USB cable and turn the ON/OFF button ON.

*Note: When new hardware is detected and the "New hardware detection wizard" screen appears, press the [Cancel] button.*

- (3) Read the serial number in the rating plate on the under cover using the barcode reader.  
The serial number is loaded to the “Serial No.:" column.

If you do not have the barcode reader, manually input the lower 9 digits of the serial number in the rating plate on the under cover from the keyboard.

Example: Enter the last nine digits 'G7G111111' if the serial number on the nameplate is printed as 'U61884-G7G111111'.

- (4) Then, open the “General Settings” window to set the general settings.  
Click the [General setting...] button.

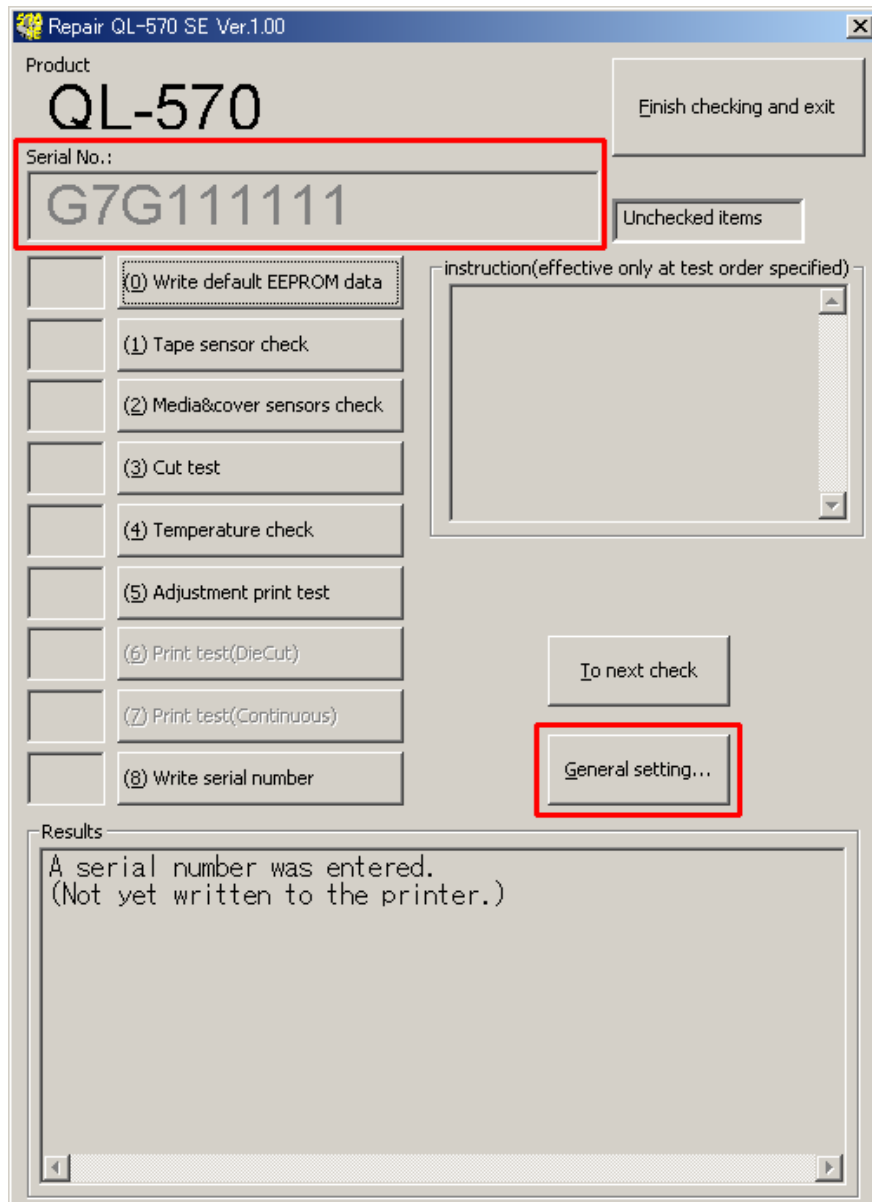

Fig. 6



(5) "General Settings"

Set various items before the inspection.

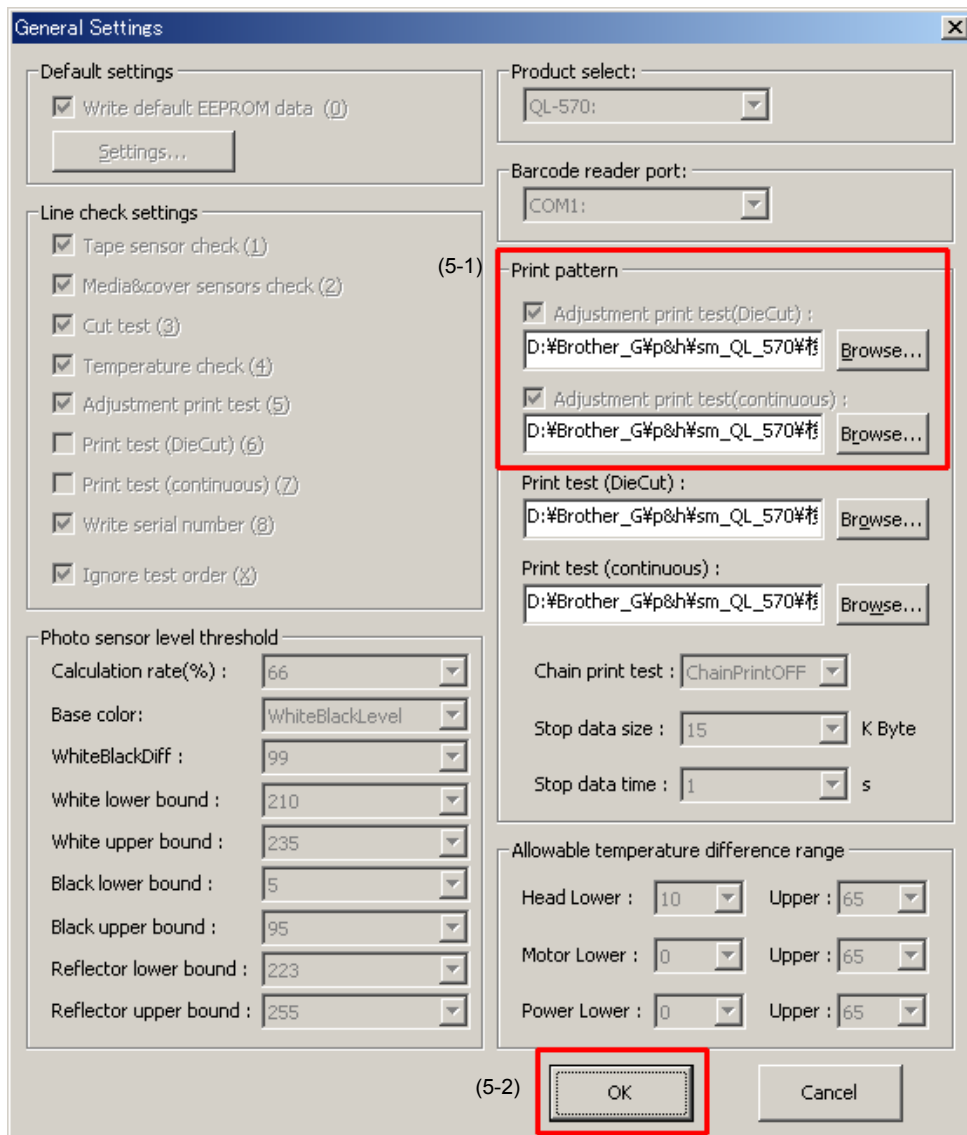

Fig. 7

(5-1) "Print pattern"

Specify a file for each print pattern.

- Setting of print pattern files

In accordance with the table below, specify a file for each print pattern of the "Print pattern" section in the "General settings" window.

Items to be examined	File name (PRN file)
" Adjustment print test (DieCut) "	DieCut latest date.prn
" Adjustment print test (continuous) "	Lenfree latest date.prn

*Note: Since the values of other items than the above are fixed, you cannot set them.*

(5-2) Click the [OK] button after completing all settings.

## [ 2 ] Use Procedure of Maintenance Software

- (1) Start up this software.
- (2) Connect the machine to your PC with the USB cable and turn the ON/OFF button ON.
- (3) Enter the serial number from the keyboard.

### [ 2-1 ] “Write default EEPROM data”

Reset the setting value of the EEPROM to the factory default value.

- (1) Click the [(0) Write default EEPROM data] button.

When initialization of the EEPROM is complete, the result is displayed in the “Results” column.

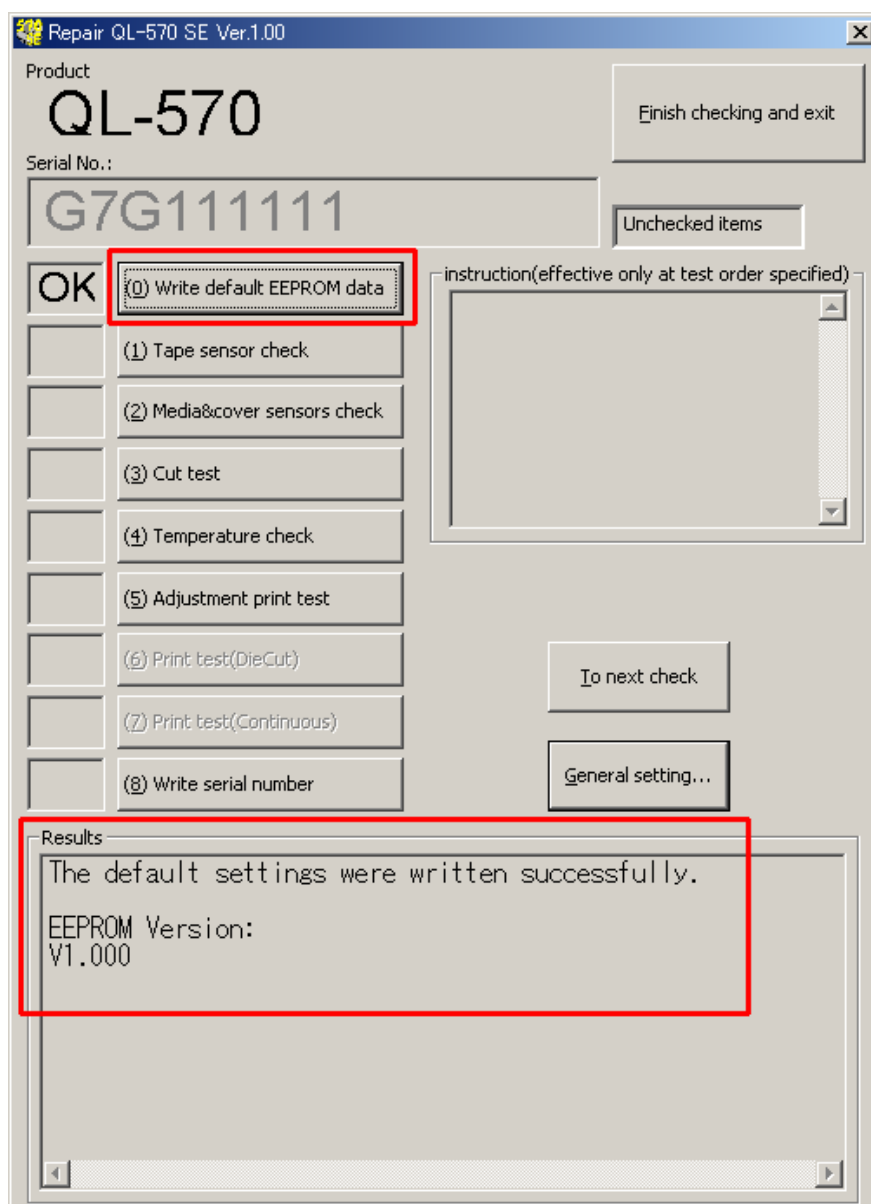

Fig. 8

## [ 2-2 ] “Tape sensor check”

- (1) Click the [(1) Tape sensor check] button.  
The following screen appears. (Fig. 10)

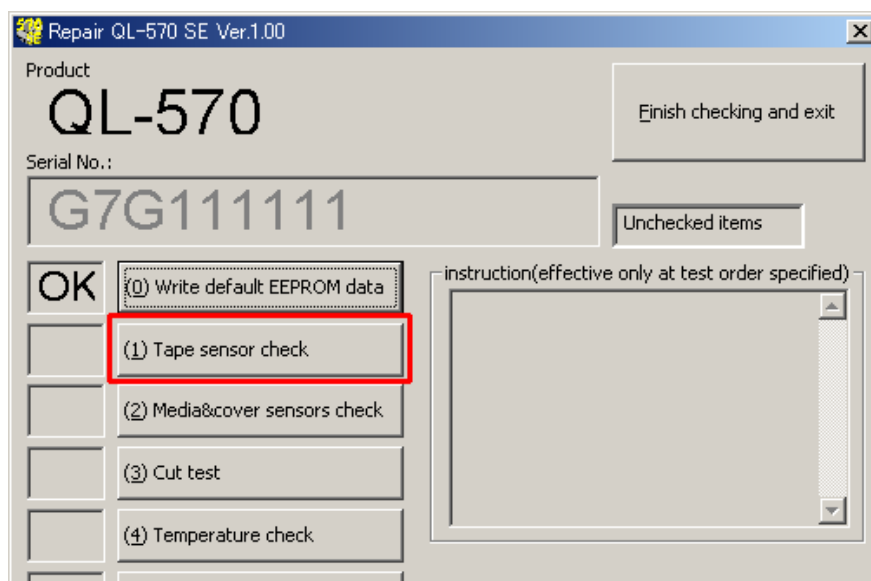

Fig. 9

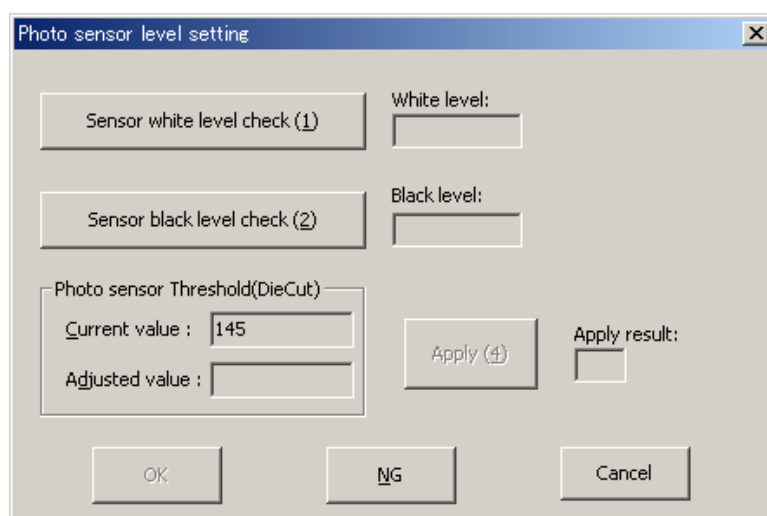

Fig. 10

- (2) Set only the backing paper (release paper) of the die-cut tape (62mm x 100mm) on the main unit. (Be sure to remove the label.)
- Align the printed mark (sensor black mark) on the backing paper to the position indicated in the figure.

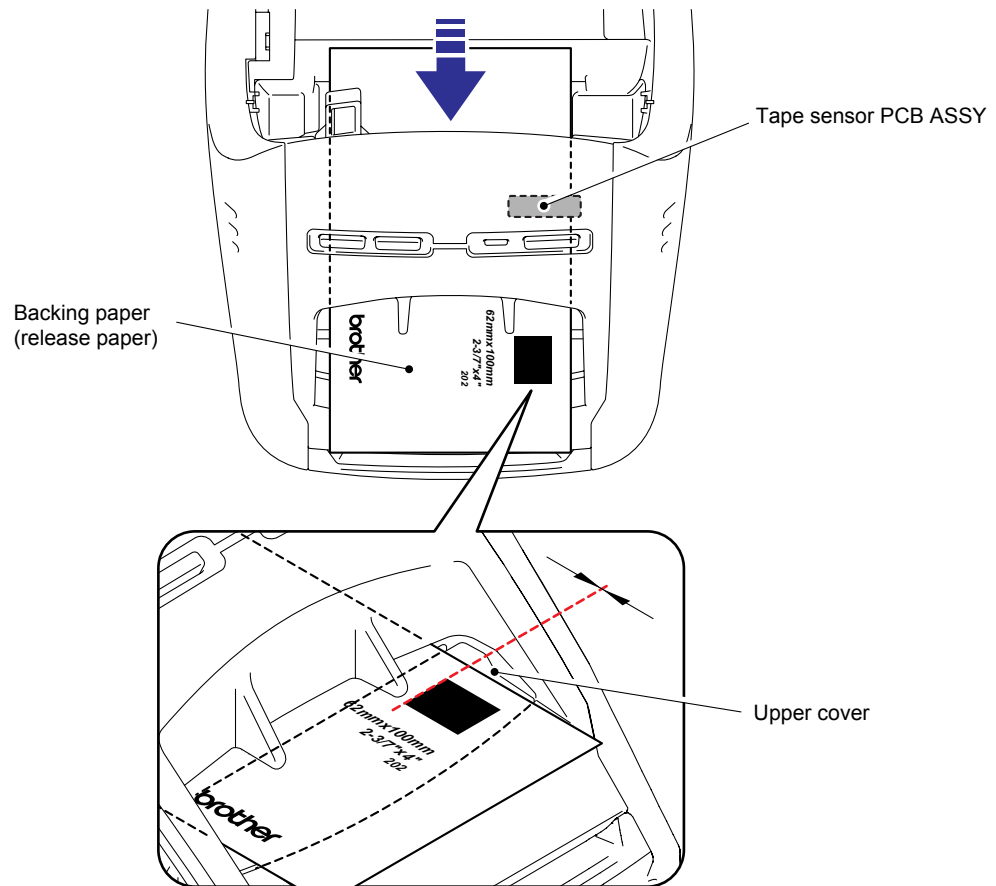

Fig. 11

- (3) Click the [Sensor white level check (1)] button.
- If the standards are satisfied, "OK" is displayed in both the "White level:" column and "Adjusted value:" column.

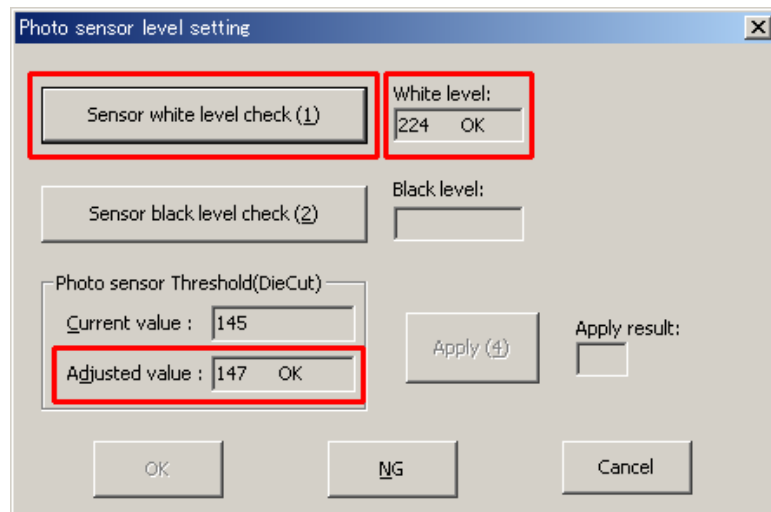

Fig. 12

- (4) Remove the paper from the main unit, and then click the [Sensor black level check (2)] button. If the standards are satisfied, "OK" is displayed in the "Black level:" column.
- (5) If all the check results are OK, click the [OK] button to go on to the next test.

**Important: If NG appears in the "Adjust value" column, implement the operation described in "APPENDIX 1.3 Use Procedure of the VR Adjustment Tool (ql500tstVRAdjust.exe)".**

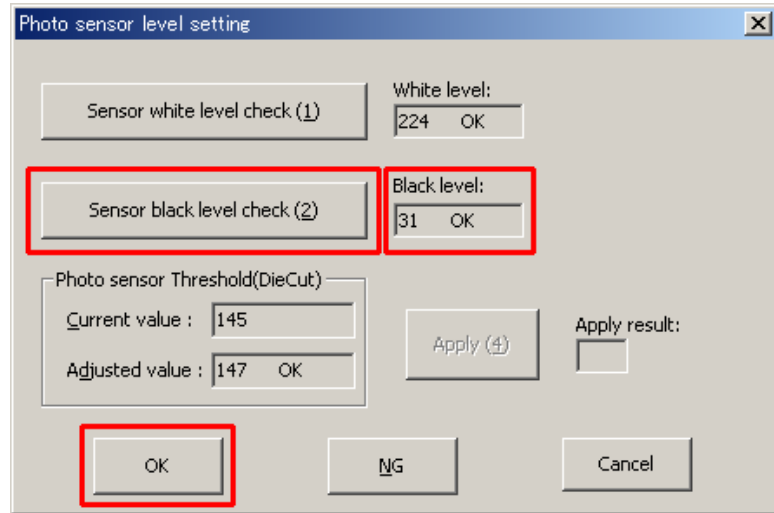
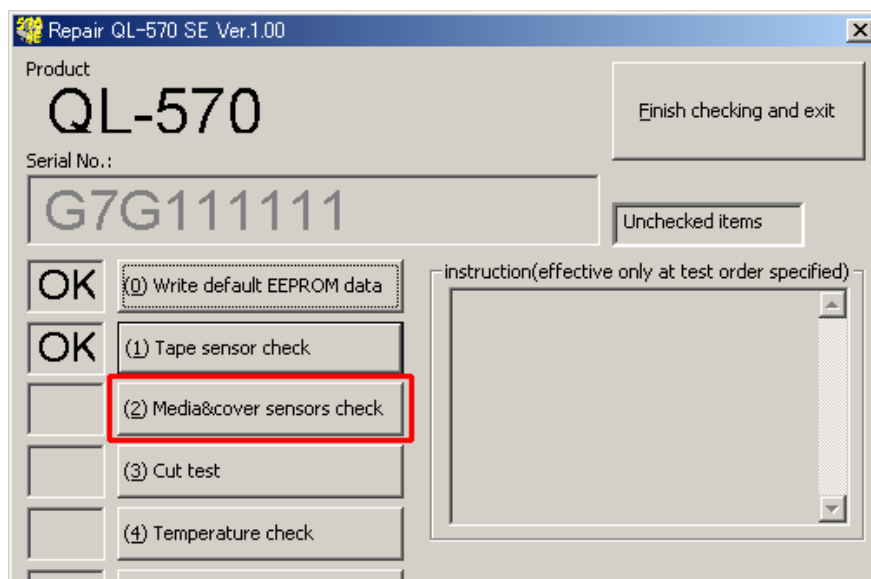

Fig. 13

**[ 2-3 ] “Media & cover sensors check”**

Check that the cover open sensor and media sensor work correctly.

(1) Click the [(2) Media&cover sensors check] button.



**Fig. 14**

- (2) Press the cover sensor arm.
- (3) Check that the last word of the message in the “Results” column is switched into “on” or “off”.
- (4) Press the media sensor.
- (5) Check that the last word of the message in the “Results” column is switched into “on” or “off”.

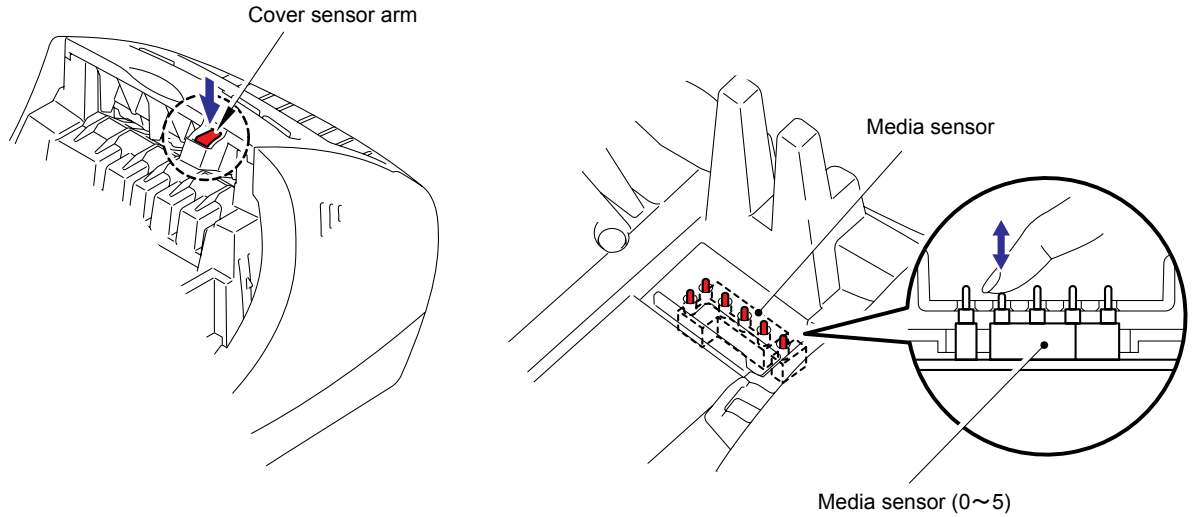

Fig. 15

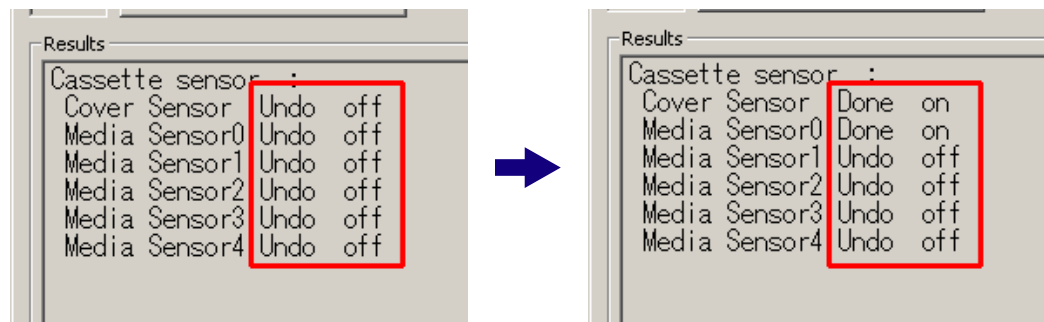

Fig. 16

- (6) When a sensor correctly responds, “Undo” in the “Results” column is replaced with “Done.”

(7) If the check result is OK, click the [(2) Quit sensors check] button. If NG, click the [Sensors test NG] button.

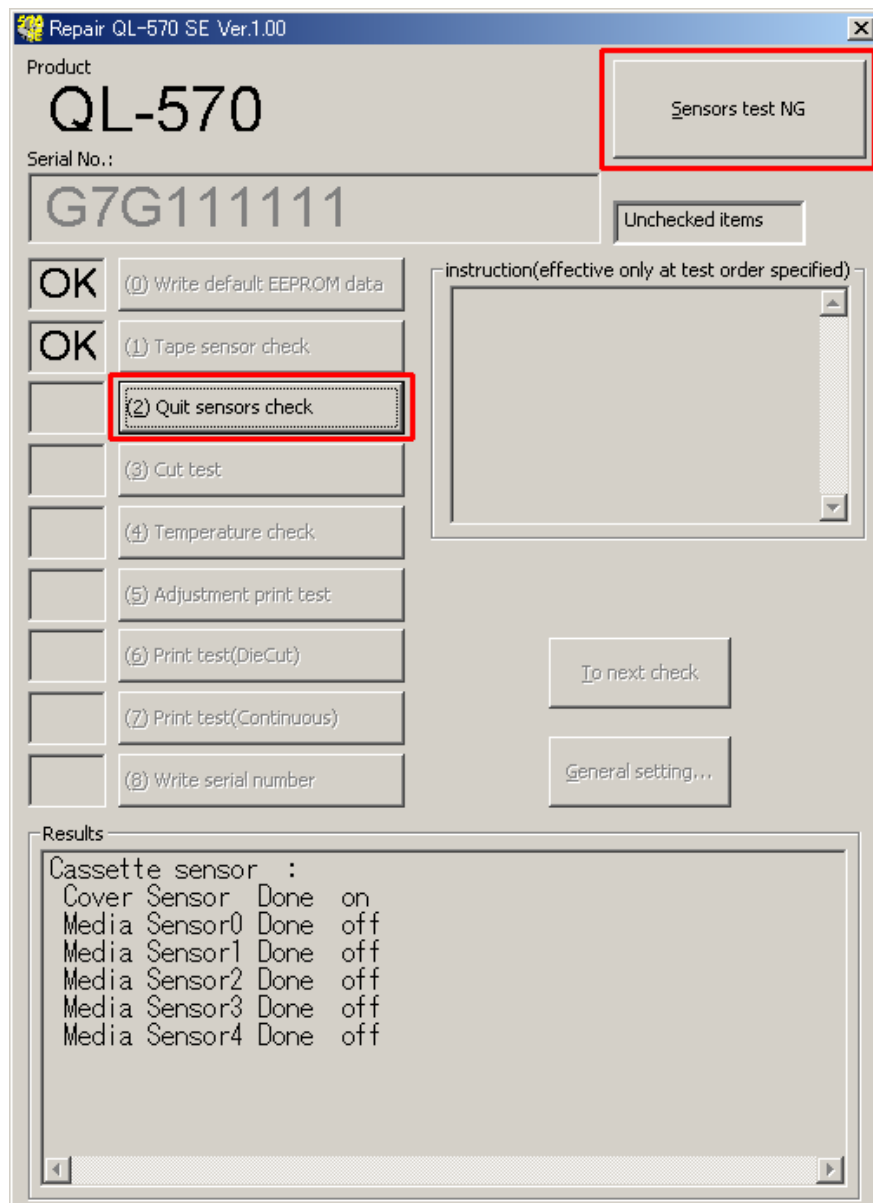

Fig. 17



## [ 2-4 ] “Cut test”

Check that the tape is fed and cut correctly.

(1) Click the [(3) Cut test] button.

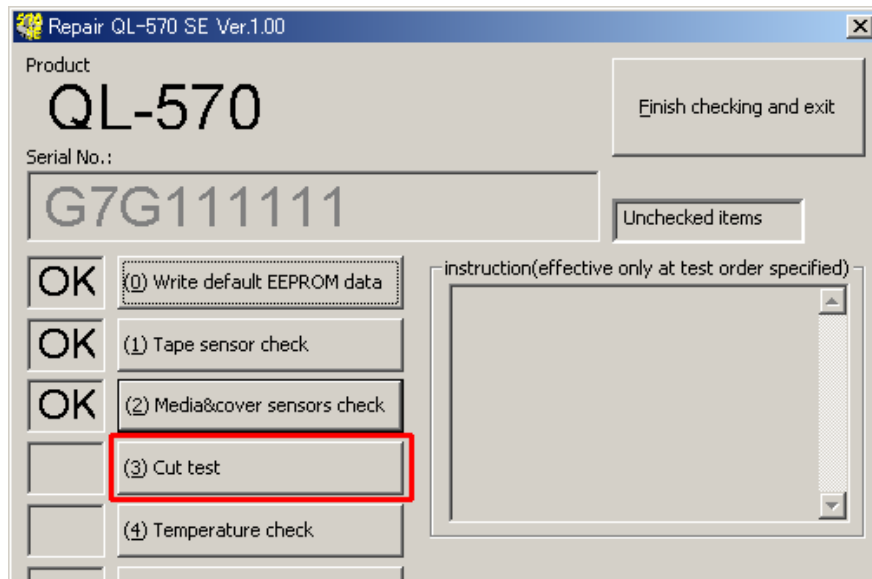

Fig. 18

(2) Set the free length roll of 62mm into the machine.

(3) Press the Feed button on the machine.

If OK, the “feed test OK” message appears in the “Results” column.

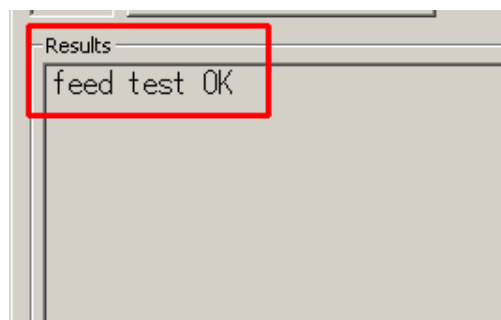
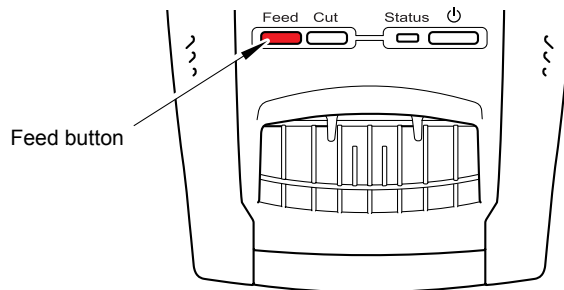

Fig. 19

(4) Press the Cut button on the machine.

If OK, the “feed and cut test OK” message appears in the “Results” column.

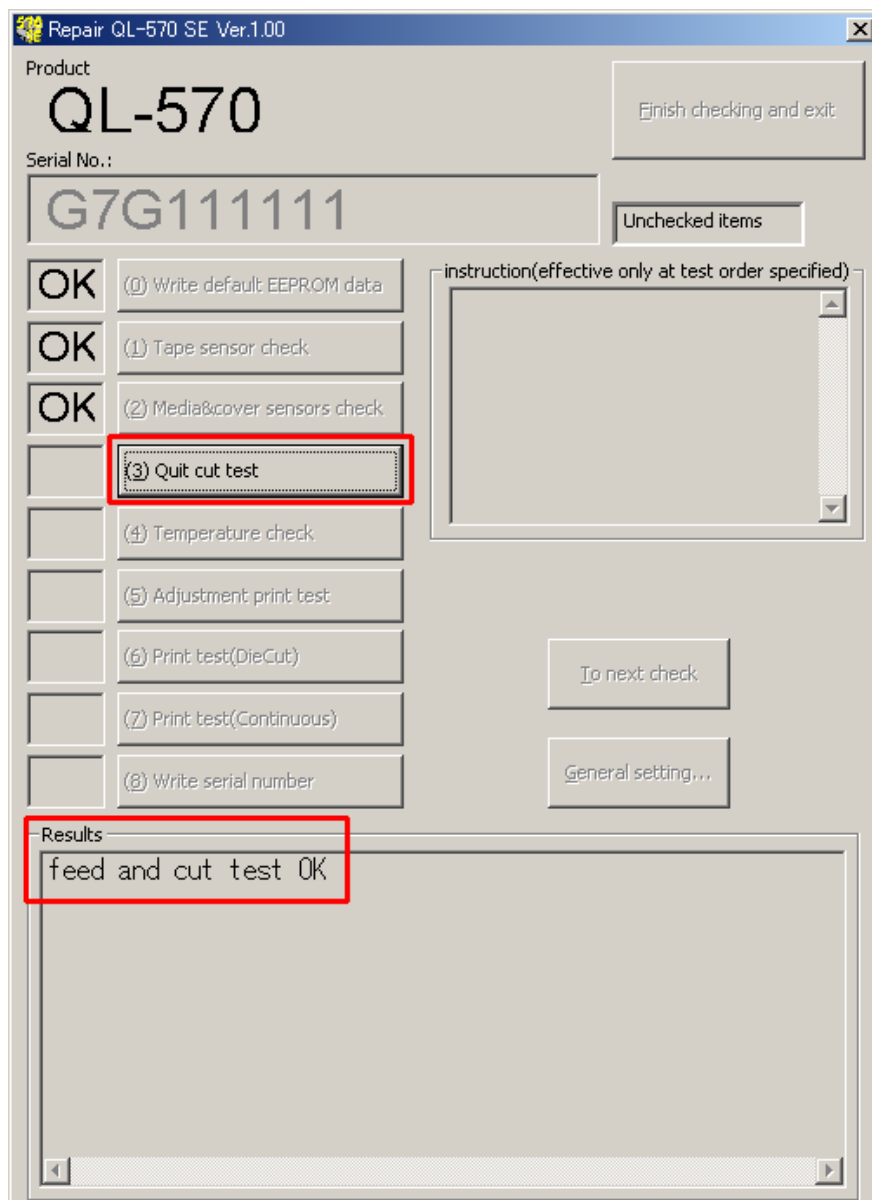
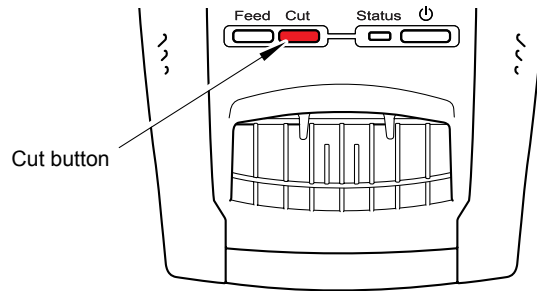

Fig. 20

(5) Click the [(3) Quit cut test] button to finish the cut test mode.

## [ 2-5 ] “Temperature check”

Check that the head temperature sensor works properly.

(1) Click the [(4) Temperature check] button.

If the standards are satisfied, “OK” is displayed in the “Results” column.

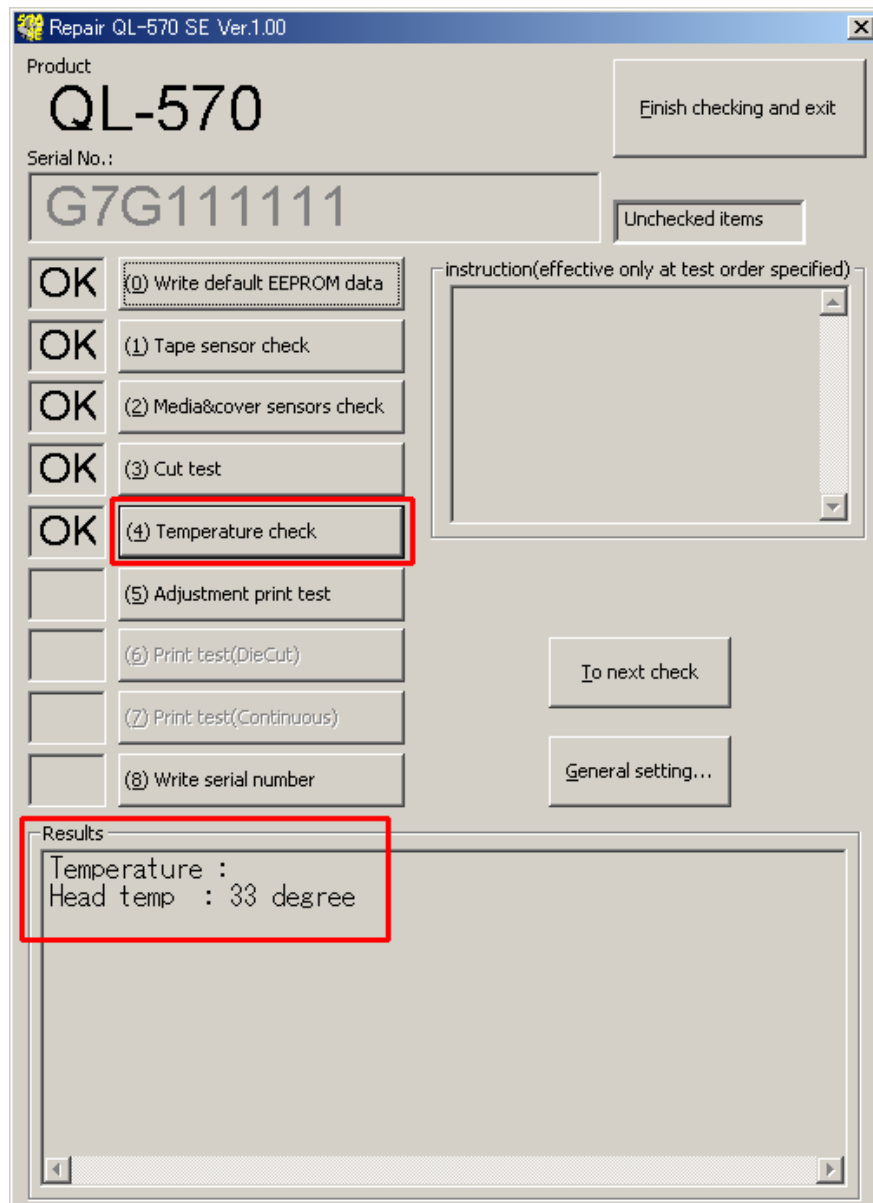

Fig. 21

## [ 2-6 ] “Adjustment print test”

Implement the printing test to adjust the energy rank and top and bottom margins.

(1) Click the [(5) Adjustment print test] button. The following screen appears. (Fig. 23)

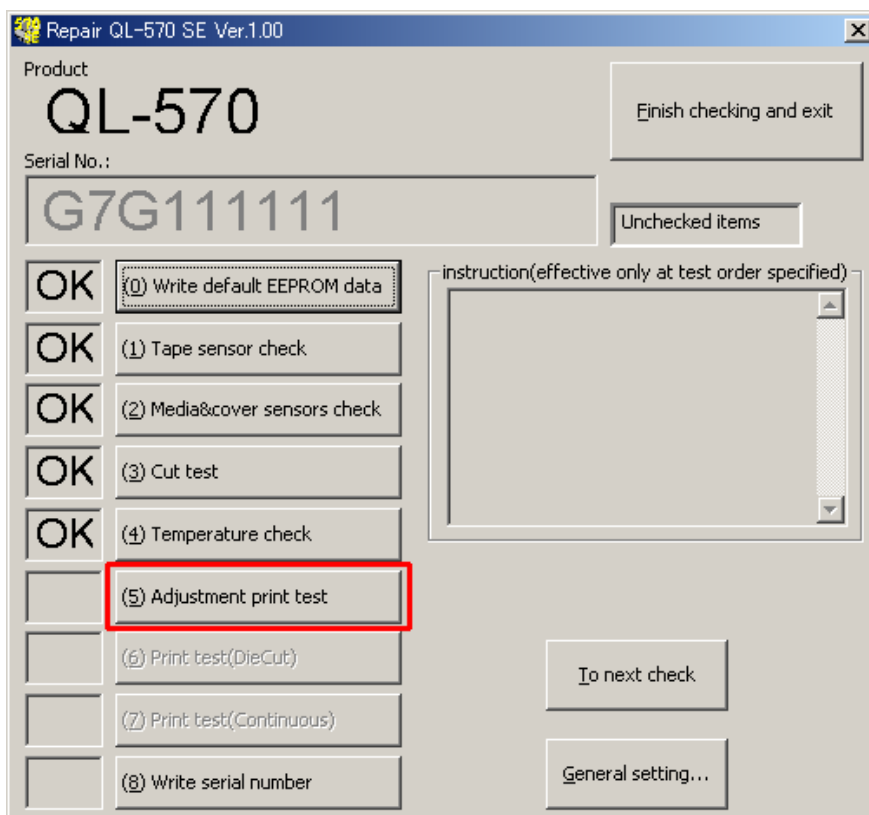

Fig. 22

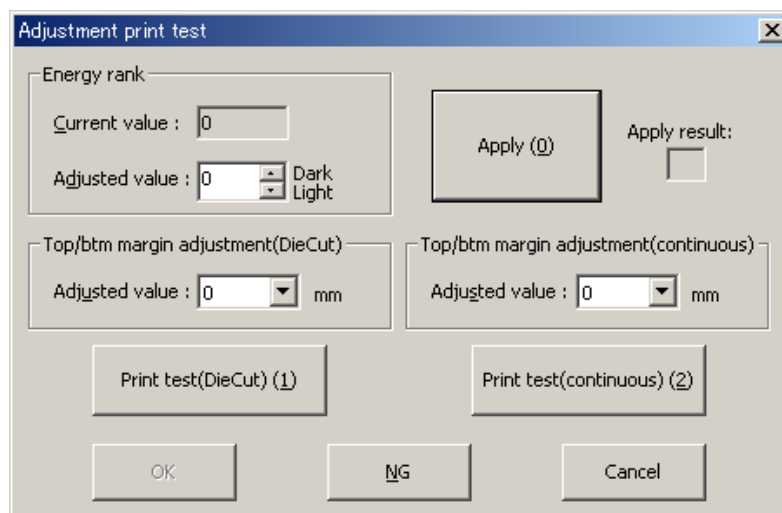

Fig. 23

*Note: The [OK] button is disabled before these two types of adjustment are completed.*

- (2) Set the free length roll of 62mm into the machine and click the [Print test(continuous) (2)] button to implement the test print.

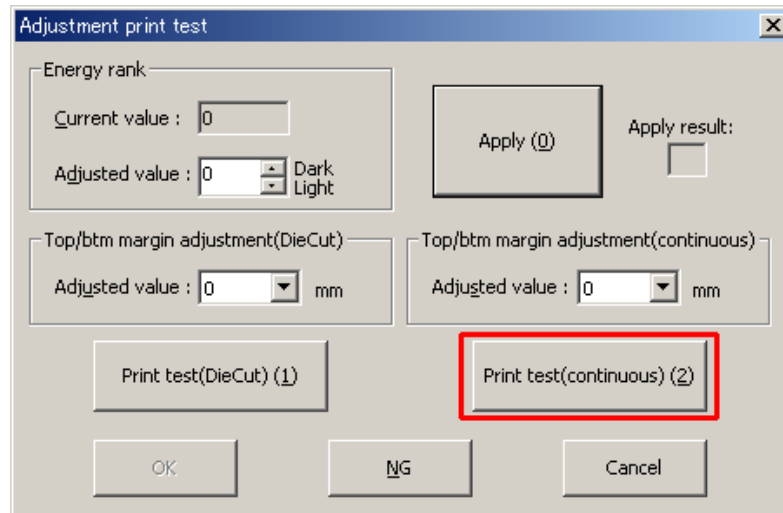

Fig. 24

- (3) Press the Cut button on the machine.  
(4) Measure the top margin of the print result. It is OK if the top margin is  $3\text{mm} \pm 0.5\text{mm}$ .

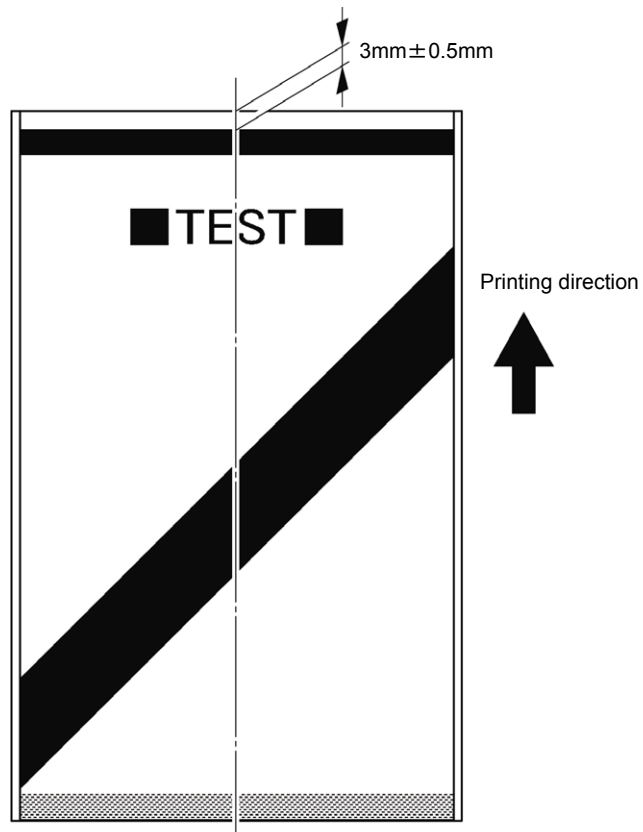

Fig. 25

- (5) If the top margin is out of the range of  $3\text{mm} \pm 0.5\text{mm}$ , change the value in the “Adjusted value” column so that the top margin is  $3\text{mm} \pm 0.5\text{mm}$ . Then, click the [Apply (0)] button.

When adjustment is complete, “OK” is displayed in the “Apply result:” column.

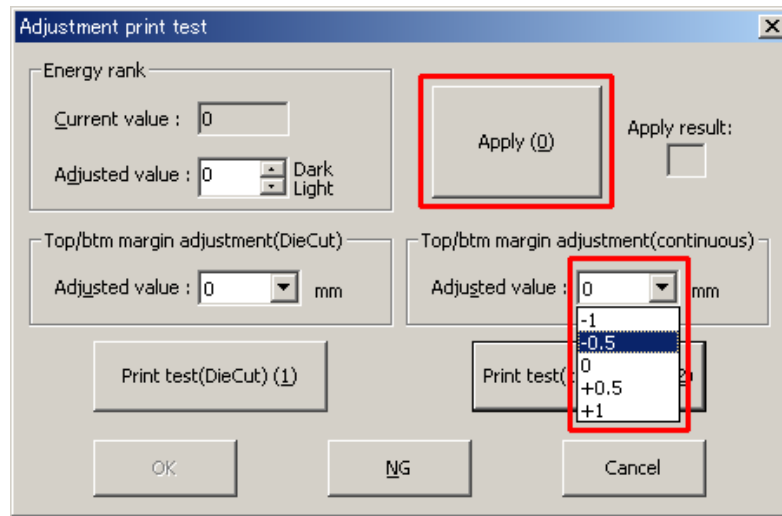

Fig. 26

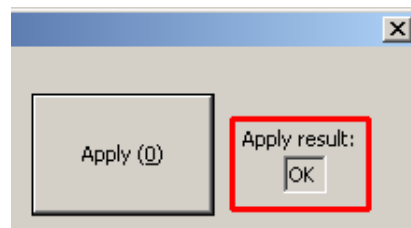

Fig. 27

- (6) Click the [Print test(continuous) (2)] button again to implement the test print. Check that the top margin of the print result is  $3\text{mm} \pm 0.5\text{mm}$ .

(7) If the check result is OK, Set the die cut roll of 62mm x 100mm into the machine and click the [Print test(DieCut) (1)] button to implement the test print.

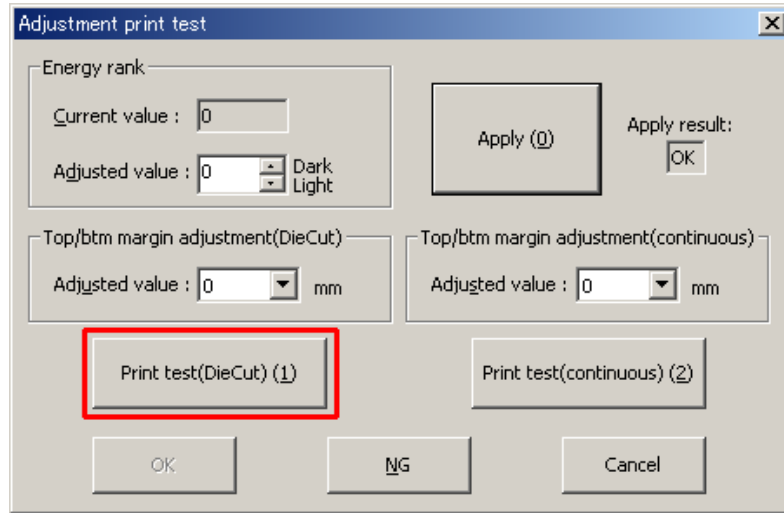

Fig. 28

(8) Measure the top margin of the print result. It is OK if the top margin is  $3\text{mm} \pm 0.5\text{mm}$ .

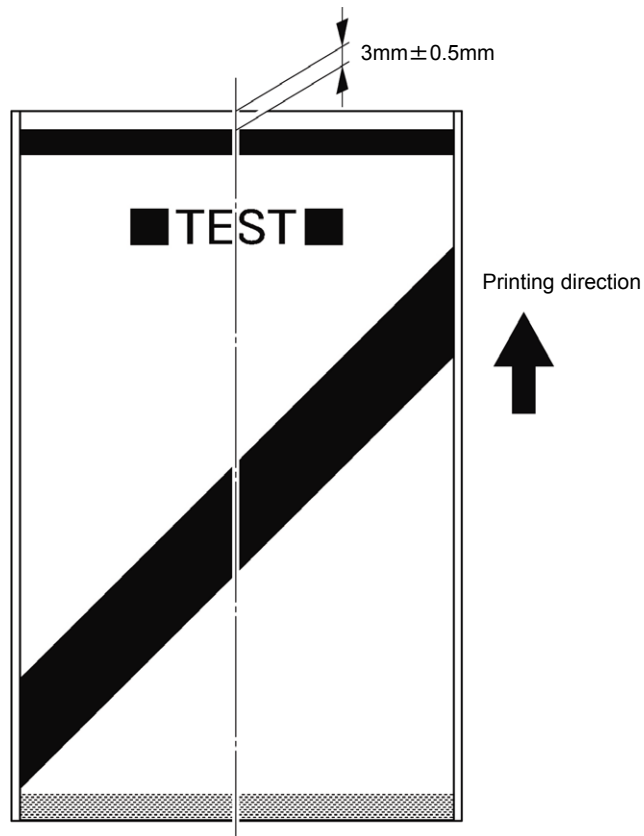

Fig. 29

- (9) If the top margin is out of the range of  $3\text{mm} \pm 0.5\text{mm}$ , change the value in the “Adjusted value” column so that the top margin is  $3\text{mm} \pm 0.5\text{mm}$ . Then, click the [Apply (0)] button.

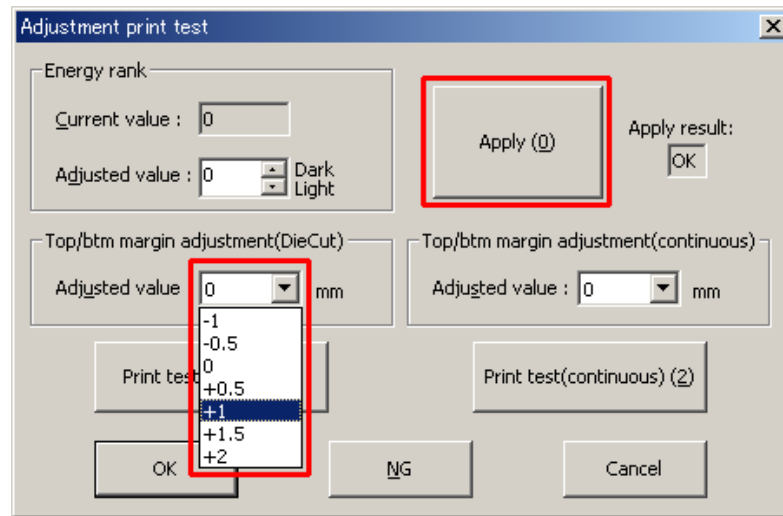

Fig. 30

- (10) Click the [Print test(DieCut) (1)] button again to implement the test print. Then, check that the top margin of the print result is  $3\text{mm} \pm 0.25\text{mm}$ .
- (11) If the check result is OK, click the [OK] button to close the “Adjustment print test” screen.

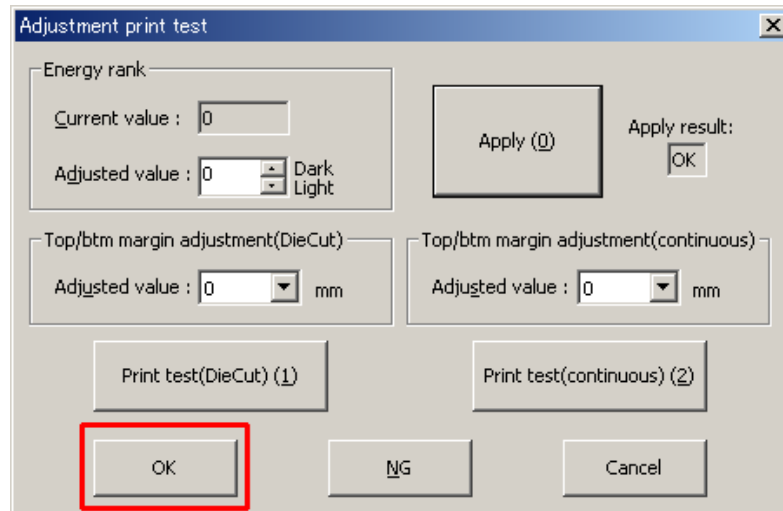

Fig. 31



[ 2-7 ] “Write serial number”

Write the USB serial number into the EEPROM.

- Click the [(8) Write serial number] button.
- When the USB serial number is written normally, “OK” appears on the left hand side of the button, and the message appears in the “Results” column.

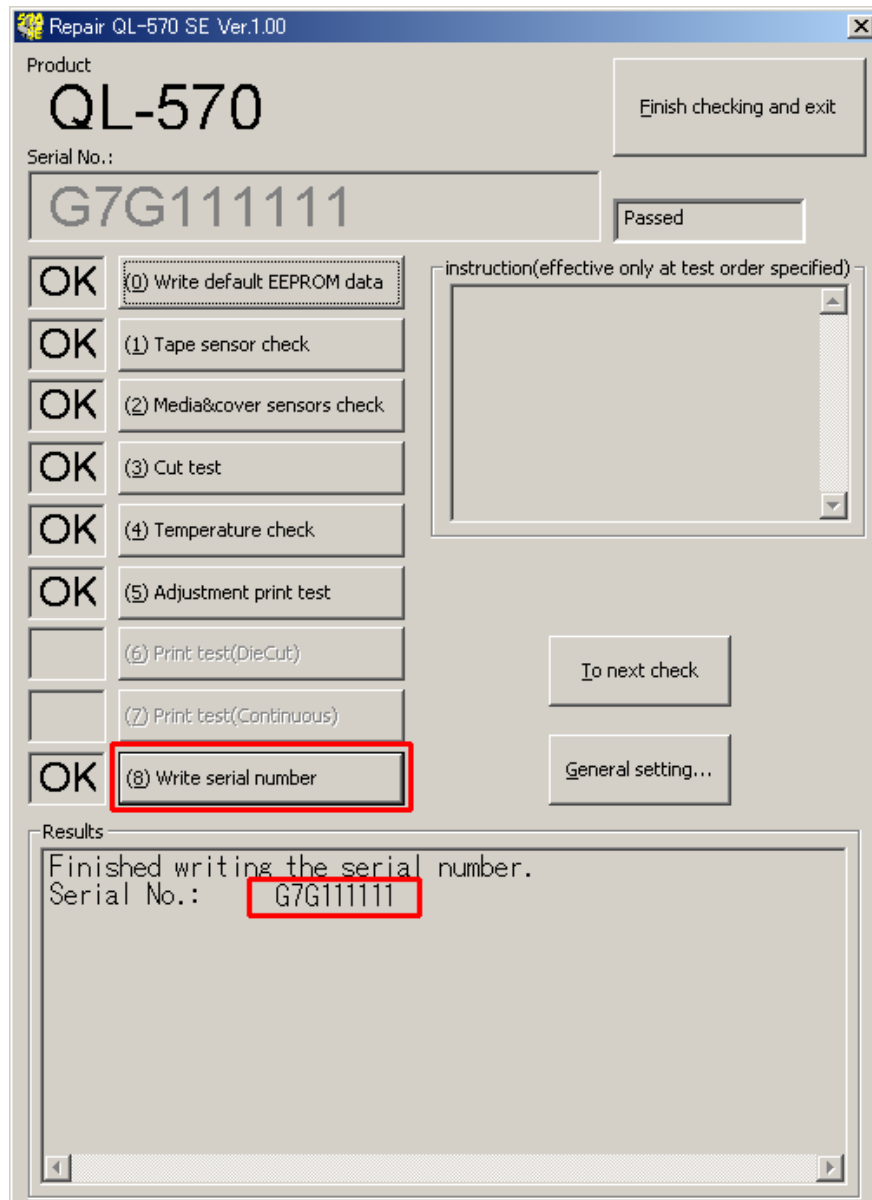

Fig. 32

### APPENDIX 1.3 Use Procedure of the VR Adjustment Tool (ql500tstVRAdjust.exe)

Be sure to make this adjustment in any of the following cases:

- When you replace the main PCB ASSY
- When you replace the tape sensor PCB ASSY
- When you replace the media PCB ASSY
- When the tape sensor check in the maintenance software tool (ql570tstSE.exe) failed

<Operating Procedure>

(1) Start the VR adjustment tool. (File name: ql500tstVRAdjust.exe)

The following screen appears. (Fig. 33)



Fig. 33

(2) Connect the machine to your PC with the USB cable and turn the ON/OFF button ON.

*Note: When new hardware is detected and the "New hardware detection wizard" screen appears, press the [Cancel] button.*

(3) Set only the backing paper (release paper) of the die-cut tape (62mm x 100mm) on the main unit.

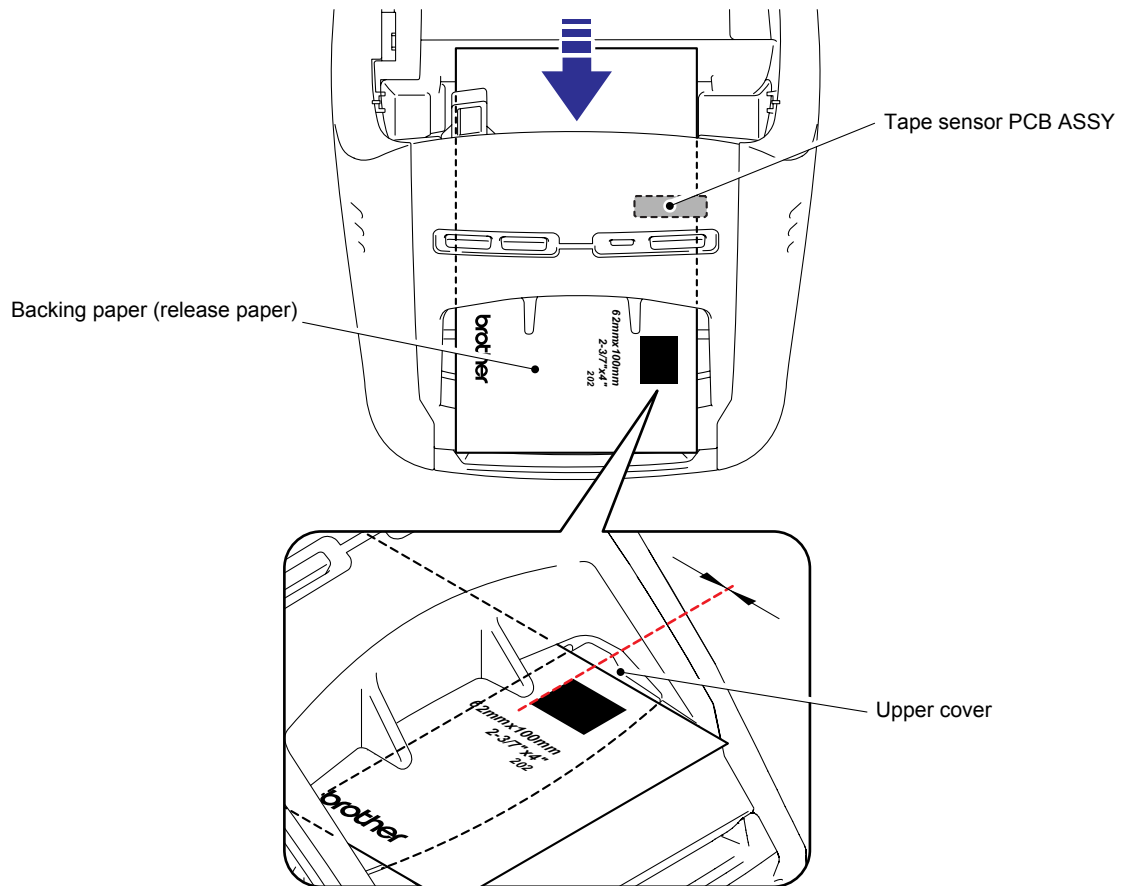

Fig. 34

(4) Click the [VR adjustment] button.

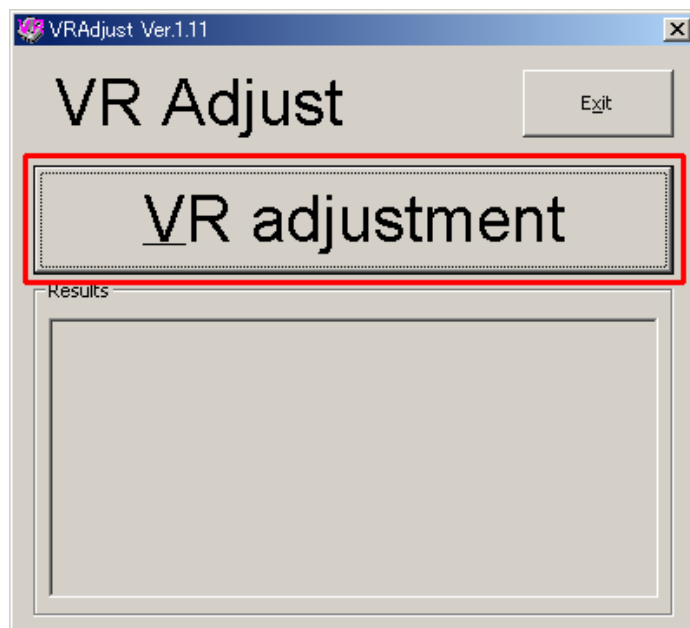

Fig. 35

- (5) If the value indicated in the “Results” column of the VR adjustment tool is in the range of 218 to 222, the result is OK. If it is out of the range and NG, proceed to the next adjustment.

<In the case of OK: The numeric value displayed is within the range of 218 to 222.>

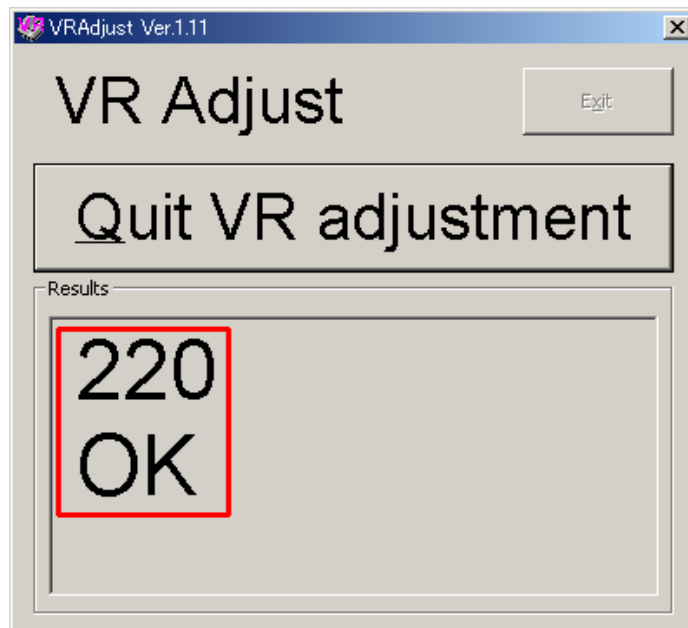

Fig. 36

<In the case of NG: Adjust the VR value.>

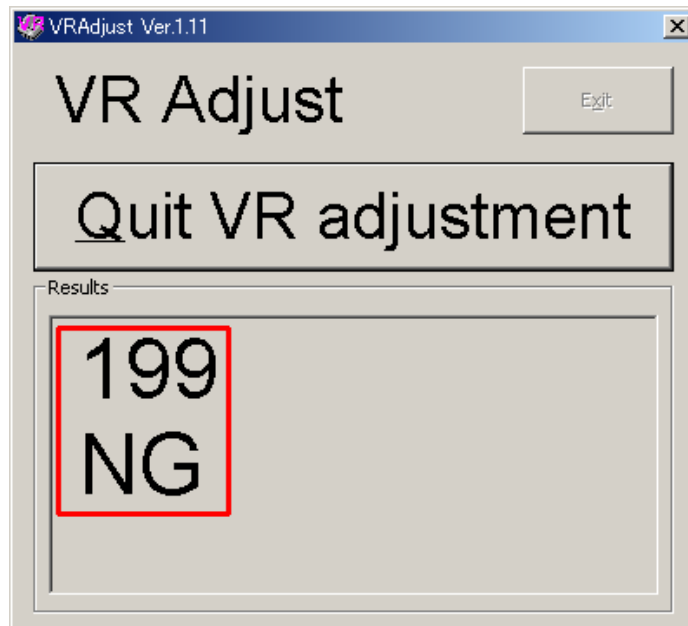

Fig. 37

- (6) When NG is displayed in the “Results” column, adjust the VR value. Remove the volume cover label from the upper cover ASSY.
- (7) Turn the VR adjustment volume provided in the machine with using a screwdriver so that the value indicated in the “Results” column is in the range of 218 to 222.  
(Make sure that a screwdriver is put into the slit on the volume and turn it slowly. Do not turn the screwdriver forcibly since the angle that the screwdriver can be turned is limited.)

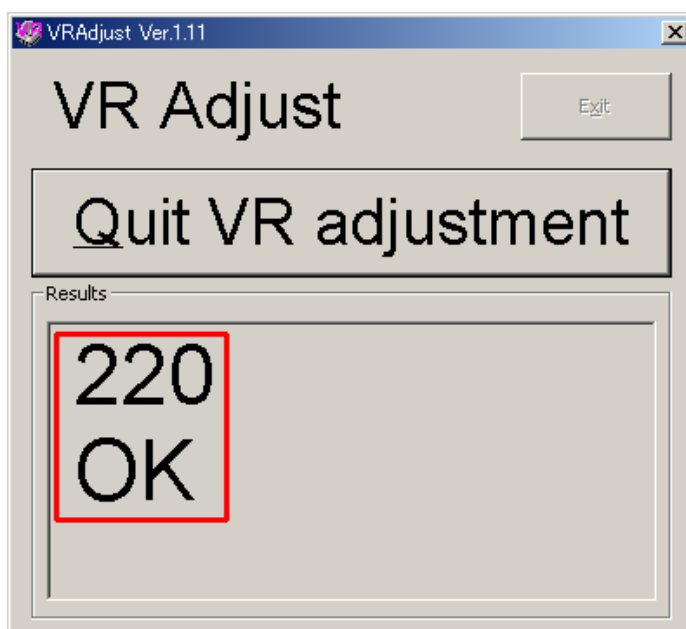
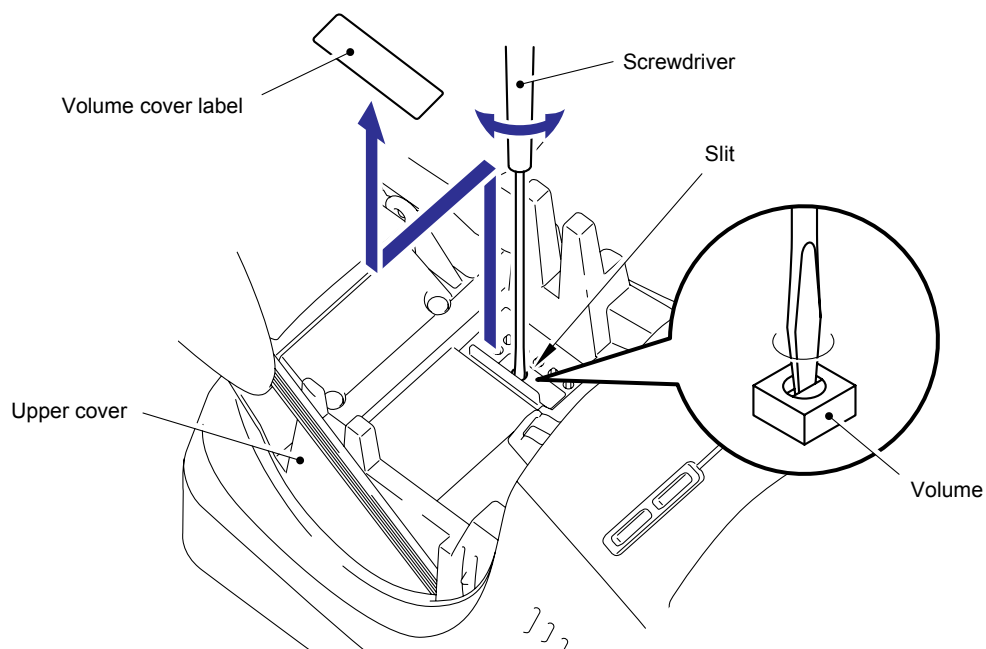

Fig. 38

- (8) After adjustment, attach a brand-new volume cover label onto the adjustment hole on the upper cover.

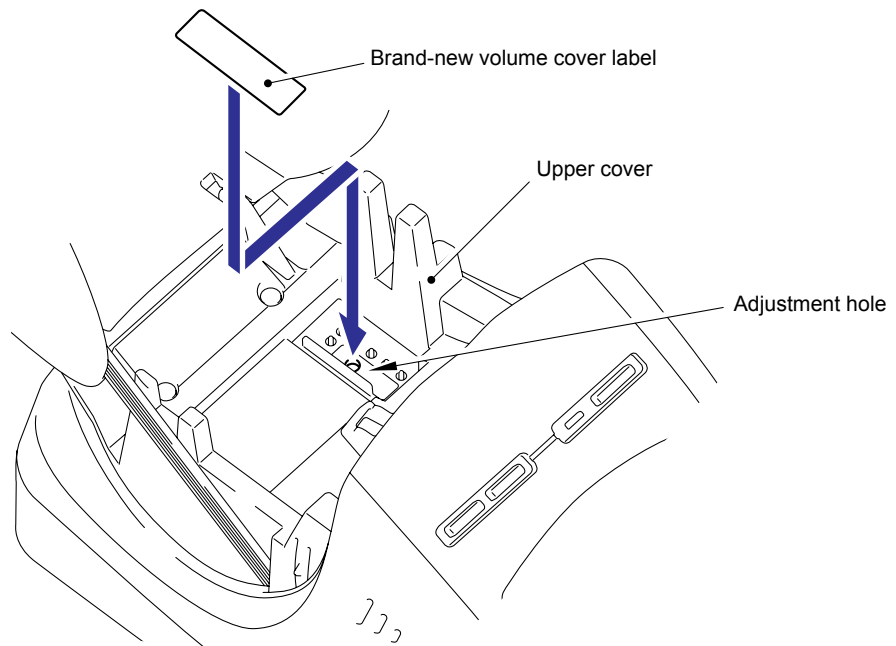

Fig. 39

- (9) Click the [Quit VR adjustment] button.

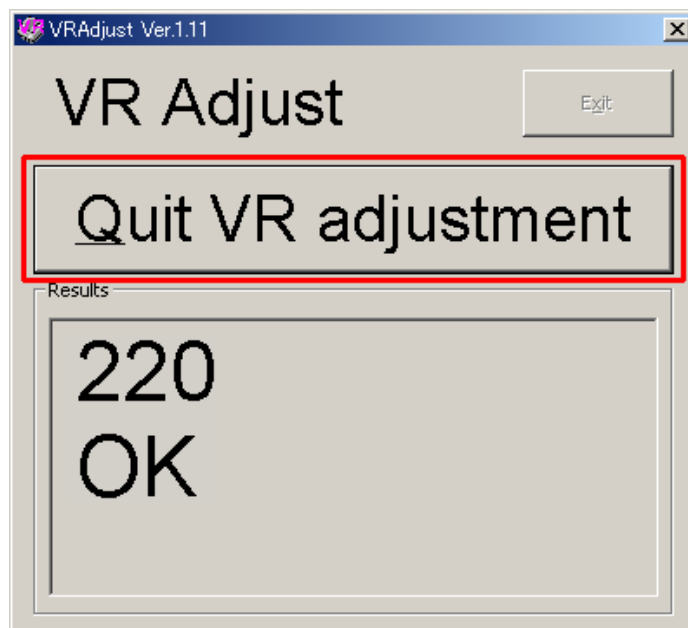

Fig. 40

(10) Click the [Exit] button to finish the software.

(11) Turn off the ON/OFF button of the machine.

This is the end of the adjustment.

*Note: Be sure not to activate the maintenance software and P-Touch editor at the same time.  
They do not work properly if they are activated at a time.*

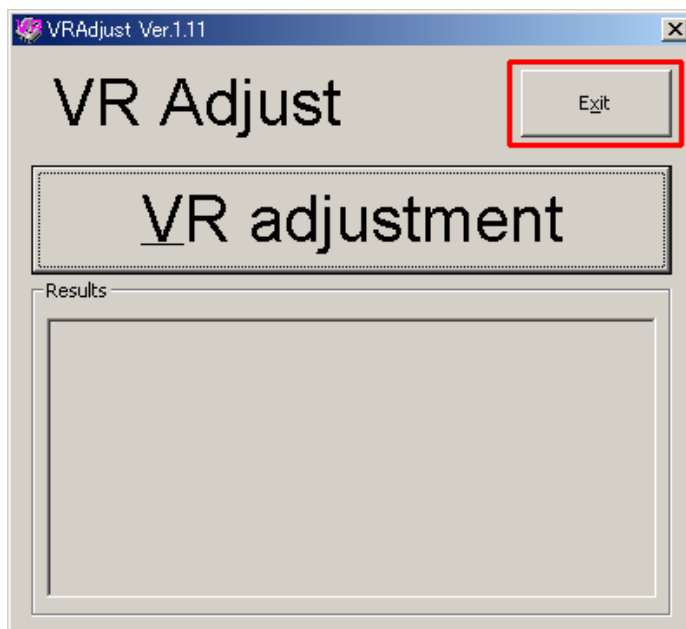

**Fig. 41**

## APPENDIX 1.4 Auto Power-OFF Setting Tool (autopoff.exe)

Be sure to use this tool to change the auto power-off setting for all models satisfy conditions below.

1. Russian model.
2. Mounted main PCB ASSY is "LBC080001 (parts code)".

*Note: This tool must be used after running the maintenance software tool (ql570tstSE.exe). Performing in wrong order would cause invalid auto power-off setting in the product.*

### <Operating Procedure>

This tool sets auto power-off time on products with Erp-Tier2 -compliant PCB for particular destination.

- (1) Connect the machine to your PC with the USB cable and turn ON the machine.

*Note: Be sure to install the driver in advance as it is required for this tool.*

- (2) Once the driver is installed, double-click "autopoff.exe" to run auto power-off setting tool. This tool can be found in "autopoff100.zip" with other tools. Extract and double-click to start it.
- (3) Once the tool starts, select the connected Printer in the "Printer:" field of the tool. Select "None" in the "Auto power-off time:" field, and press the [Apply] button.

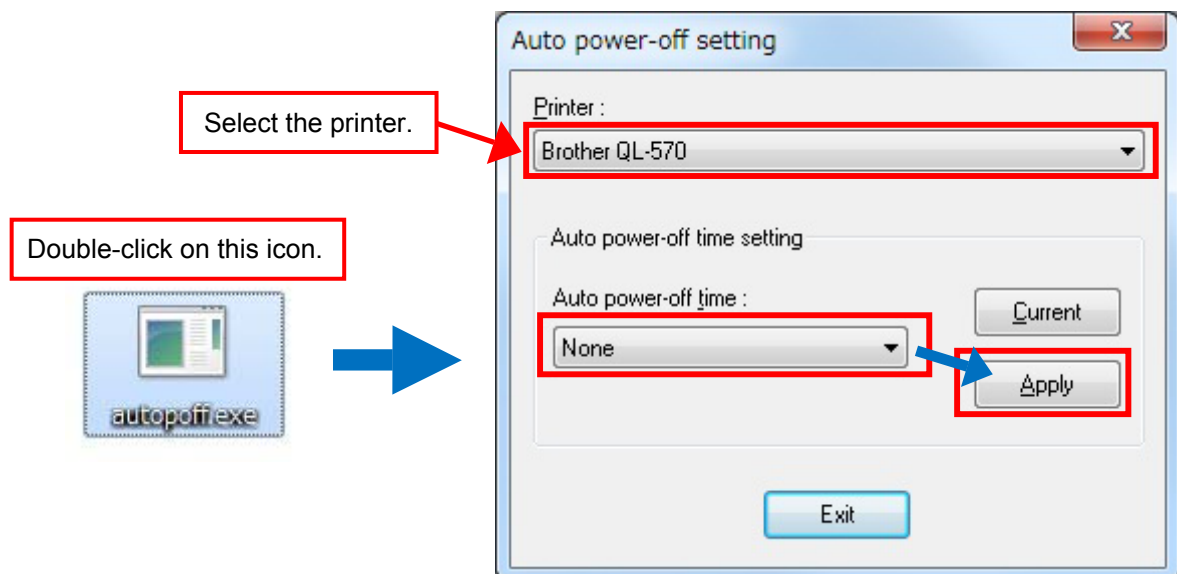
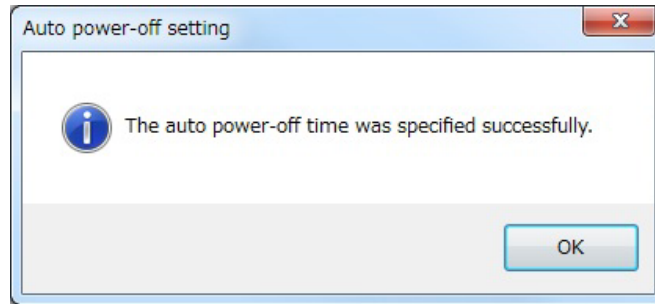

Fig. 42 Auto power-off setting tool



- (4) Once the auto power-off setting is written properly, the window below appears. Press the [OK] button to close auto power-off setting tool.



**Fig. 43 Window appears when the writing completed properly**

*Note: When the auto power-off setting is failed on writing, the window below appears.*

- (1) When the connected printer is not same with printer selected on auto power-off setting tool, error message below appears. Check the "Printer:" field on auto power-off setting tool again. (See fig.42)

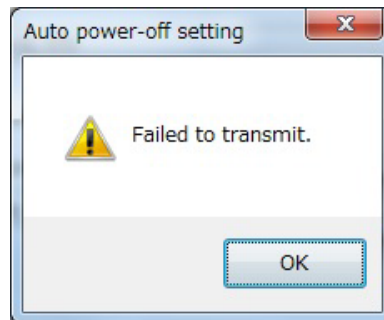

**Fig. 44 Transmission error**

- (2) When the auto power-off setting tool is used for printers do not satisfy required condition 2 on page 31, error message below appears. Check printer's configuration.

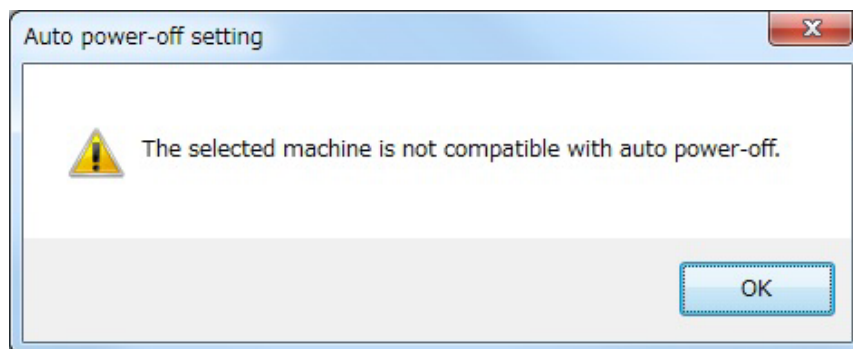

**Fig. 45 Auto power-off non-compatible error**

**brother**