

# 1 Installing EasyShare software



CD packaged with  
your frame.



- Install the software.
- After installing the software, return to this Getting Started Guide.

# 2 Connecting the power cable

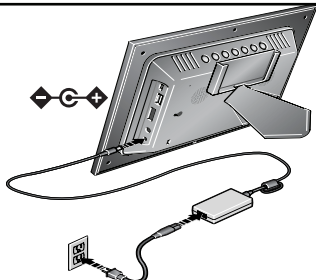

Your power cable (included with the frame) may be different from the one pictured. Use the plug that accommodates your type of power outlet.

For package contents, see your product package.

To purchase accessories, visit [www.kodak.com/go/digitalframes](http://www.kodak.com/go/digitalframes).

[www.kodak.com/go/digitalframesupport](http://www.kodak.com/go/digitalframesupport)

### 3 Inserting memory card/USB device

#### Memory card

(sold separately)

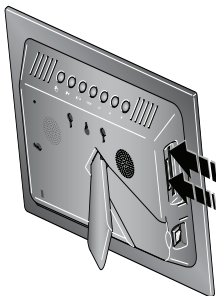

CompactFlash/  
MicroDrive

Secure Digital/  
Memory Stick/  
xD/  
MultiMediaCard

#### USB device

(digital camera, flash drive, card reader, etc.—sold separately)

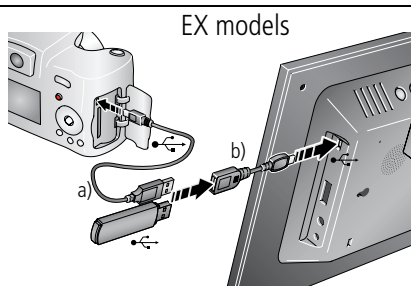
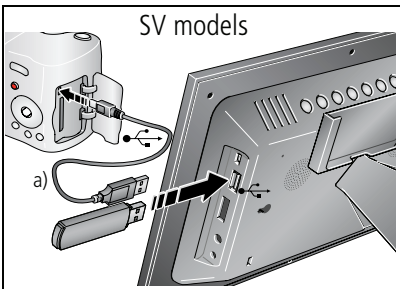

a) USB cable included with your USB device.

b) USB adapter cable included with your EX model picture frame.

## 4 Activating the remote control

Pull out the tab to activate the battery.

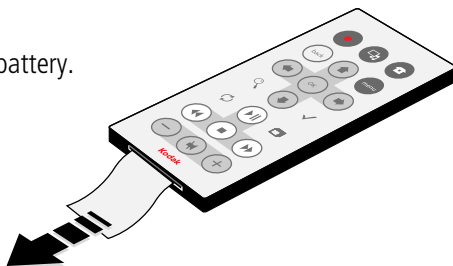

## 5 Turning on the frame

1. Press the switch to On.

2. Then use the remote control to turn the power off and on.

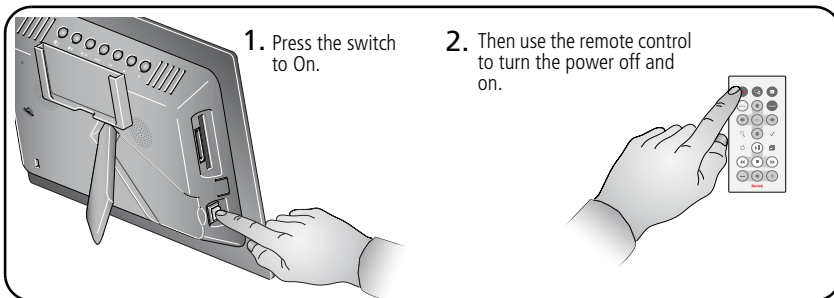

## 6 Setting the language

The language setup screen appears the first time you turn on the frame.



1.  to change.
2. OK to accept.

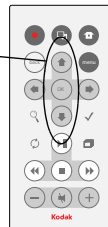

## 7 Viewing your slide show



- A slide show starts automatically when you turn on the frame.\*
- The pictures and videos - on the card or device you inserted - are displayed in the order they're stored on the card or device.

\* EX models: with NO card inserted, the network connection screen appears and helps you connect to your wireless network. See Chapter 3.

## 8

# Keep learning about your frame!

## Congratulations!

You have:

- set up your picture frame.
- inserted your card or other USB device.
- enjoyed your first slide show.



## Even more fun!

Turn the page to learn about more great features of your frame, including personalizing your picture viewing. You can also customize your frame to match your style or decor! For all great frame accessories, visit

**[www.kodak.com/go/digitalframes](http://www.kodak.com/go/digitalframes)**.

**Visit [www.kodak.com/digitalframesupport](http://www.kodak.com/digitalframesupport) for:**

- the extended user's guide
- interactive troubleshooting and repairs
- interactive tutorials
- FAQs
- downloads
- product registration

*[www.kodak.com/go/digitalframesupport](http://www.kodak.com/go/digitalframesupport)*

## Front View

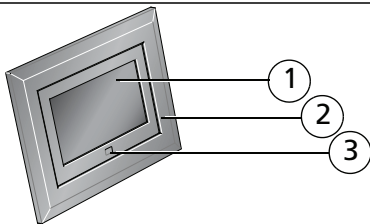

- 1 LCD screen
- 2 Faceplate
- 3 Remote control sensor

## Back/Left Side View

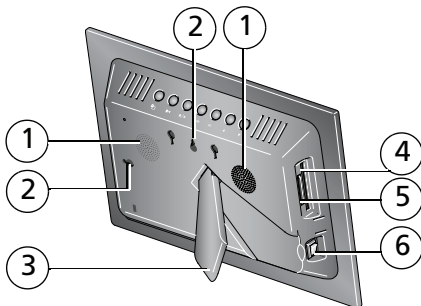

- 1 Speakers
- 2 Wall mount hangers
- 3 Frame stand
- 4 Memory card slot - CF, MD



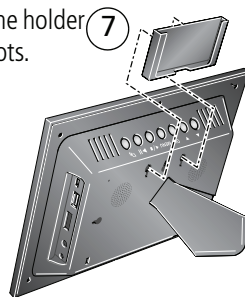

Slide the holder **7** into slots.

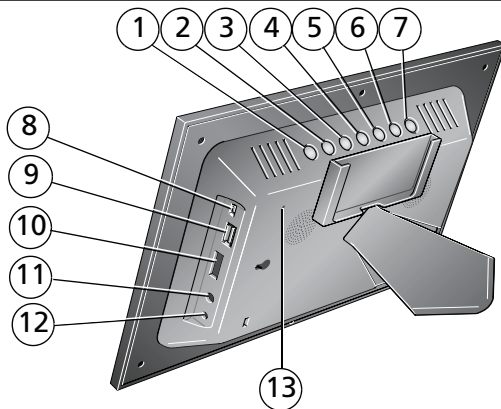

- 5 Memory card slot - SD, MS, xD, MMC
- 6 On/Off switch
- 7 Remote control holder (removable)

# Top/Right Side View



- |   |  |    |   |
|---|--|----|---|
| 1 | Picture/music toggle  | 8  | USB connector (All models, use to connect to computer; EX models, also use to connect to camera/USB device - with adapter cable.) |
| 2 | Play/Pause            | 9  | USB connector (SV models only, use to connect to camera/USB device. Not available on EX models.)                                  |
| 3 | Stop/Back             | 10 | Volume control  |
| 4 | Menu   | 11 | Headphone jack                                   |
| 5 | OK   | 12 | DC-In (12 V)                                     |
| 6 | Down ▼   | 13 | Reset button  |
| 7 | Up ▲   |    |   |

# Remote Control

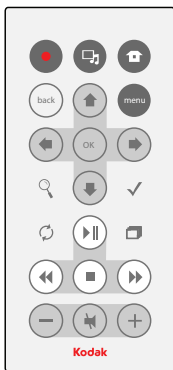

\* First, turn on the power switch on the frame.

	Button	Press to
		power* turn on/off the picture frame.
		home return to the home screen.
		pics/music toggle between viewing pictures and selecting music.
	menu	menu display menu choices.
	back	back return to the previous screen. stop a slide show, display thumbnails.
	OK	OK accept the current selection.
		4-way navigate through pictures or menus.
		zoom magnify the picture.
		rotate rotate the picture, 90° clockwise each press.
		select mark pictures for an operation.
		slide show play a slide show.
		play/pause play/pause a video or slide show.
		rewind rewind a video.
		fast forward fast forward a video.
		stop stop a video, display the first frame. stop a slide show, display thumbnails.
	-/+	volume decrease (-) or increase (+) the volume.
		mute mute audio.



# 1

## Doing more

All buttons and controls described are on the remote control unless otherwise specified.

### Viewing pictures and videos

#### Thumbnails view



- To view your pictures as multi-up thumbnails, press ■ when a slide show is playing.
- To navigate through the thumbnails, press ⬅➡.
- To play a video (📺), highlight it and press OK.

#### Single view



- To view a single, full-screen picture, highlight it in thumbnails view and press OK.
- To magnify a picture up to 8X, press 🔍. To view other parts of the picture, press ⬅➡. Press OK to return.
- To rotate a picture, press 🔄.

#### Slide show

- To start a slide show from any selected picture (thumbnail or single view), press 📄.

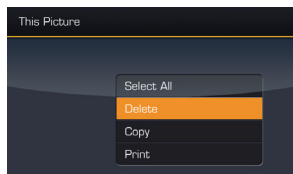
## Deleting pictures



- 1 Display a picture in single view, then press .
- 2 Press  to highlight Delete, then press OK.
- 3 Highlight Delete and press OK again to confirm. To cancel the deletion, highlight Exit, then press OK.

*The picture/video is deleted.*



To delete multiple pictures/videos, see [page 11](#).

NOTE: You can delete pictures/videos from a card, internal memory, or some connected USB devices. EX models—you cannot delete from remote locations over the wireless network.

## Copying pictures

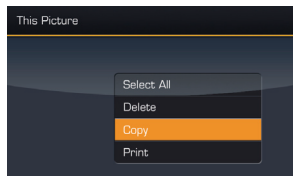
Copy pictures/videos from your current viewing location to internal memory (not available on SV710), or other connected devices.



- 1 Display a picture in single view, then press .
- 2 Press  to highlight Copy, then press OK.
- 3 Press  to highlight the location you want to copy to, then press OK.



To copy multiple pictures/videos, see [page 11](#).

To copy pictures/videos to your computer in connected or wireless (EX models) mode, see your extended user's guide at [www.kodak.com/go/digitalframesupport](http://www.kodak.com/go/digitalframesupport).



## Selecting multiple pictures

Use the multi-select feature to copy or delete two or more pictures/videos; or to play a slide show of selected pictures/videos.

### Selecting one at a time

- 1 In thumbnails view, press  to find a picture/ video.
- 2 Press  to select a picture/video. Repeat to select additional pictures/videos.  
*A check mark appears on the picture. Press  again to remove a check mark. You can now copy, delete, or view a slide show of all selected pictures.*

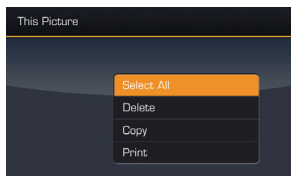

### Selecting all at once

- 1 Press  whenever pictures/videos are displayed (slide show, video, single picture).
- 2 Press  to highlight Select All, then press OK.  
*A check mark appears on all pictures/videos in your current location.*
- 3 To remove the check marks, press , then Unselect All.



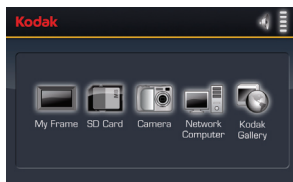

## Viewing pictures from a new location





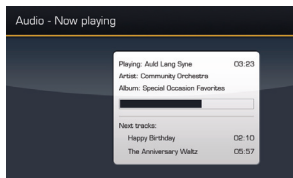

- 1 Press  .  
*All connected devices are listed.*
- 2 Press  to highlight the device you want, then press OK.

## Playing music

- 1 Press  to interrupt your picture or slide show and display the Audio screen.
- 2 Press  to locate your music files. Then press OK.



- 3 Press  to go to the next or previous song. Then press OK.  
*Your music starts playing.*
- 4 Press  to return to your picture or slide show.  
*Your selected music continues to play as the slide show resumes. Videos play without their related audio.*
- 5 To turn off music, press , then .
- 6 Press  again to return to your pictures.

# 2

## Using WiFi® (EX models only)

For more information on using the wireless features of your frame, see your user's guide at [www.kodak.com/go/digitalframesupport](http://www.kodak.com/go/digitalframesupport) or visit [www.kodak.com/go/wifisupport](http://www.kodak.com/go/wifisupport).

### Before you start

On your computer, make sure you:

- Install the software that is packaged with your frame ([page 1](#)).
- Enable media sharing in Windows Media Player 11 (select Library → Media Sharing, then follow the screen directions).

### Setting up your wireless network

Perform this one-time setup to connect your picture frame to your wireless network.

- 1 Make sure your computer is turned on.
- 2 Remove all memory cards or other USB devices from your frame and turn it on.  
*The first time you turn on your frame (after you select your language), the Network Connection screen appears.*
- 3 Follow the directions on the Network screens to connect to your wireless home network.





NOTE: If you have network security turned on, you are prompted to enter your security information.

To set up your network at a later time, press , highlight Settings , and press OK.

[www.kodak.com/go/digitalframesupport](http://www.kodak.com/go/digitalframesupport)

## Viewing pictures over your wireless network

When you view pictures on your frame over your wireless network, they are accessed from your computer via Windows Media Player 11, or over the Internet from Kodak EasyShare gallery.









- 1 Turn on your computer and your picture frame. Then press .
- 2 Press   to highlight your computer name, then press OK. If you have multiple computers on your network, first select Network Computer  .
- 3 Follow the prompts to choose the pictures, then press OK.

*Pictures are displayed as thumbnails. Press  to play a slide show.*

If your computer name is not listed on the Home screen, or for more information, see user's guide at [www.kodak.com/go/digitalframesupport](http://www.kodak.com/go/digitalframesupport).

## Setting up your Kodak gallery account

You can display pictures directly from the Kodak gallery via the Internet. Perform this one-time setup to connect your frame to your existing Kodak gallery account.

- 1 Press , then highlight Settings  and press OK.
- 2 Select Kodak EasyShare gallery and press OK.
- 3 Use the     to enter your existing gallery username (usually your email address) and password. Highlight Done, then press OK.
- 4 Press . Kodak Gallery  appears as a choice on the Home screen.

# 3

## Appendix

### Important safety instructions



#### CAUTION:

**Do not disassemble this product; there are no user-serviceable parts inside. Refer servicing to qualified service personnel. Do not expose this product to liquid, moisture, or extreme temperatures. The use of controls, adjustments, or procedures other than those specified herein may result in exposure to shock and/or electrical or mechanical hazards. If the LCD breaks, do not touch the glass or liquid. Contact Kodak customer support.**

- The use of an accessory that is not recommended by Kodak may cause fire, electric shock, or injury. For approved accessories, visit [www.kodak/go/accessories](http://www.kodak/go/accessories).
- Use only a USB-certified computer equipped with a current-limiting motherboard. Contact your computer manufacturer if you have questions.
- When removing the battery from the remote, allow it to cool; it may be hot.
- Follow all warnings and instructions supplied by the battery manufacturer.
- Use only batteries approved for this product to avoid risk of explosion.
- Keep batteries out of the reach of children.
- Do not allow batteries to touch metal objects, including coins. Otherwise, a battery may short circuit, discharge energy, become hot, or leak.
- Do not disassemble, install backward, or expose batteries to liquid, moisture, fire, or extreme temperature.
- Remove the battery when the product is stored for an extended period of time. In the unlikely event that battery fluid leaks inside the product, contact Kodak customer support.
- In the unlikely event that battery fluid leaks onto your skin, wash immediately with water and contact your local health provider. For additional health-related information, contact your local Kodak customer support.
- Dispose of batteries according to local and national regulations. Visit [www.kodak.com/go/kes](http://www.kodak.com/go/kes).
- Do not charge non-rechargeable batteries.

For more information on batteries, visit [www.kodak.com/go/batterytotypes](http://www.kodak.com/go/batterytotypes).

- Digital picture frame and remote control battery may include perchlorate material. Special handling may apply in California.
- Read and follow all warnings and instructions supplied by the battery manufacturer.



### **CAUTION:**

**EX models only:** When using this product, it should be installed and operated with a minimum distance of 7.9 in. (20cm) for 2.4 GHz operations between the radiator and your body. This transmitter must not be collocated or operated in conjunction with any other antenna or transmitter.

### **Upgrading your software and firmware**

Download the latest versions of the software included on the Kodak EasyShare software CD and the frame firmware (the software that runs on the frame). See [www.kodak.com/go/digitalframedownloads](http://www.kodak.com/go/digitalframedownloads).

### **Additional care and maintenance**

- Wipe the LCD gently with a soft, lint-free cloth or an untreated lens-cleaning tissue. Do not use cleaning solutions unless designed specifically for LCD screens. Do not allow chemicals, such as suntan lotion, to contact painted surfaces.
- Service agreements are available in some countries. Contact a dealer of Kodak products for more information.
- For digital frame disposal or recycling information, contact your local authorities. In the US, visit the Electronics Industry Alliance Web site at [www.eiae.org](http://www.eiae.org) or visit [www.kodak.com/go/digitalframesupport](http://www.kodak.com/go/digitalframesupport).

### **Limited warranty**

Kodak warrants Kodak consumer electronic products and accessories ("Products"), excluding batteries, to be free from malfunctions and defects in both materials and workmanship for one year from the date of purchase. Retain the original dated sales receipt. Proof of the date of purchase will be required with any request for warranty repair.

### **Limited warranty coverage**

Warranty service is only available from within the country where the Products were originally purchased. You may be required to ship Products, at your expense, to the authorized service facility for the country where the



Products were purchased. Kodak will repair or replace Products if they fail to function properly during the warranty period, subject to any conditions and/or limitations stated herein. Warranty service will include all labor as well as any necessary adjustments and/or replacement parts. If Kodak is unable to repair or replace a Product, Kodak will, at its option, refund the purchase price paid for the Product provided the Product has been returned to Kodak along with proof of the purchase price paid. Repair, replacement, or refund of the purchase price are the sole remedies under the warranty. If replacement parts are used in making repairs, those parts may be remanufactured, or may contain remanufactured materials. If it is necessary to replace the entire Product, it may be replaced with a remanufactured Product. Remanufactured Products, parts and materials are warranted for the remaining warranty term of the original Product, or 90 days after the date of repair or replacement, whichever is longer.

### **Limitations**

This warranty does not cover circumstances beyond Kodak's control. This warranty does not apply when failure is due to shipping damage, accident, alteration, modification, unauthorized service, misuse, abuse, use with incompatible accessories or attachments (such as third party ink or ink tanks), failure to follow Kodak's operation, maintenance or repacking instructions, failure to use items supplied by Kodak (such as adapters and cables), or claims made after the duration of this warranty. Kodak makes no other express or implied warranty for this product, and disclaims the implied warranties of merchantability and fitness for a particular purpose. In the event that the exclusion of any implied warranty is ineffective under the law, the duration of the implied warranty will be one year from the purchase date or such longer period as required by law. The option of repair, replacement, or refund is Kodak's only obligation. Kodak will not be responsible for any special, consequential or incidental damages resulting from the sale, purchase, or use of this product regardless of the cause. Liability for any special, consequential or incidental damages (including but not limited to loss of revenue or profit, downtime costs, loss of the use of the equipment, cost of substitute equipment, facilities or services, or claims of your customers for such damages resulting from the purchase use or failure of the Product), regardless of cause or for breach of any written or implied warranty is expressly disclaimed.

### **Your rights**

Some states or jurisdictions do not allow exclusion or limitation of incidental or consequential damages, so the above limitation or exclusion may not apply to you. Some states or jurisdictions do not allow limitations on how long an implied warranty lasts, so the above limitation may not apply to you. This warranty gives you specific rights, and you may have other rights which vary from state to state or by jurisdiction.

### **Outside the United States and Canada**

In countries other than the United States and Canada, the terms and conditions of this warranty may be

[www.kodak.com/go/digitalframesupport](http://www.kodak.com/go/digitalframesupport)

different. Unless a specific Kodak warranty is communicated to the purchaser in writing by a Kodak company, no warranty or liability exists beyond any minimum requirements imposed by law, even though defect, damage, or loss may be by negligence or other act.

### **FCC compliance and advisory**



Kodak EasyShare digital picture frame

This equipment has been tested and found to comply with the limits for a Class B digital device, pursuant to Part 15 of the FCC Rules. These limits are designed to provide reasonable protection against harmful interference in a residential installation.

This equipment generates, uses, and can radiate radio frequency energy and, if not installed or used in accordance with the instructions, may cause harmful interference to radio communications. However, there is no guarantee that interference will not occur in a particular installation.

If this equipment does cause harmful interference to radio or television reception, which can be determined by turning the equipment off and on, the user is encouraged to try to correct the interference by one or more of the following measures: 1) reorient or relocate the receiving antenna; 2) increase the separation between the equipment and the receiver; 3) connect the equipment to an outlet on a circuit different from that to which the receiver is connected; 4) consult the dealer or an experienced radio/TV technician for additional suggestions.

Any changes or modifications not expressly approved by the party responsible for compliance could void the user's authority to operate the equipment. Where shielded interface cables have been provided with the product or specified additional components or accessories elsewhere defined to be used with the installation of the product, they must be used in order to ensure compliance with FCC regulation.

### **FCC and Industry Canada**

This device complies with Industry Canada RSS-210 and FCC Rules. Operation is subject to the following two conditions: (1) this device may not cause harmful interference, and (2) this device must accept any interference received, including interference that may cause undesired operation.

### **CE**

Hereby, Eastman Kodak Company declares that this Kodak product is in compliance with the essential requirements and other relevant provisions of Directive 1999/5/EC.

This digital picture frame EX811 and EX1011 transmits in 10dBm. In France, the power level is limited to

10dBm in outdoor environments, per regulations. When in France, use the wireless functions of this device indoors only.

### Canadian DOC statement

**DOC Class B Compliance**—This Class B digital apparatus complies with Canadian ICES-003.

**Observation des normes-Classe B**—Cet appareil numérique de la classe B est conforme à la norme NMB-003 du Canada.

### Waste Electrical and Electronic Equipment labeling



In the European Union, do not discard this product as unsorted municipal waste. Contact your local authorities or go to [www.kodak.com/go/recycle](http://www.kodak.com/go/recycle) for recycling program information.

### Australian C-Tick



### MPEG-4

Use of this product in any manner that complies with the MPEG-4 visual standard is prohibited, except for use by a consumer engaging in personal and non-commercial activities.

## Kodak

Eastman Kodak Company

Rochester, New York 14650

© Eastman Kodak Company, 2007

Kodak and EasyShare are trademarks of Eastman Kodak Company.

4J6095\_en