

SERVICE
MANUAL **PM-25**

marantz®

model **PM-25**

Stereo Amplifier

MARANTZ DESIGN AND SERVICE

Using superior design and selected high grade components, MARANTZ company has created the ultimate in stereo sound. Only **original MARANTZ parts** can insure that your MARANTZ product will continue to perform to the specifications for which it is famous.

Parts for your MARANTZS equipment are generally available to our National Marantz Subsidiary or Agent.

ORDERING PARTS:

Parts can be ordered either by mail or by telex. In both cases, correct part number has to be specified. If you order by mail, fulfil MARANTZ order forms.

MARANTZ INTERNATIONAL
Quality & Service Dept.
80, Rue des Deux Gares,
B-1070 Brussels
Belgium
Phone: 02/525.70.22 or 525.70.23
Telefax: 02/525.6160

MARANTZ NATIONAL PARTS DEPARTMENT
20525 Nordhoff Street
Chatsworth, California 91311
Phone: 1-800-423-5108
Phone: 1-213-998-9333

The following information must be supplied to eliminate delays in processing your order:

1. Complete address
2. Complete part numbers and quantities required
3. Description of parts
4. Model number for which part is required
5. Way of shipment
6. Signature: any order form or telex must be signed otherwise such part order will be considered as null and void.

PARTS ORDERING:

Parts may be ordered from the following addresses:

AUSTRIA
HORNPHON
Vertriebsgesellschaft GmbH
Wienerbergstrasse 1
A 1101 Wien
Austria
Telex: 132.332

AUSTRALIA
MARANTZ AUSTRALIA
PTY., Ltd.
19 Chard Road
Brookvale, NSW 2100
Australia
Telex: 24121

BELGIUM
SVD DIVISION MARANTZ
Industrialaan 1
1720 Groot-Bijgaarden
Belgium
Telex: 24466

CHILE
MARANTZ
DIVISION OF PHILIPS S.A.
Av. Santa Maria, 0760
Casilla 2687
Santiago
Telex: 240.239

DENMARK
MARANTZ
DIVISION OF PHILIPS
SERVICE A/S
Prags Boulevard 80
Postbox 1919
DK-2300 København S
Denmark
Telex: 31201

FINLAND
MARANTZ
DIVISION OF OY PHILIPS Ab
Kaivokatu 8
00100 Helsinki
Finland
Telex: 124811

FRANCE
MARANTZ FRANCE
4 Rue Bernard Palissy
92600 Asnieres
France
Telex: 611651

GERMANY
MARANTZ GERMANY GmbH
Max-Planck-Strasse 22
6072 Dreieich 1
Germany
Telex: 529821

THE NETHERLANDS
Elpro b.v.
De Limiet 3
4131 NR Vianen
The Netherlands
Telex: 47679

NORWAY
MARANTZ
DIVISION OF PHILIPS A/S
Sandstuveien 40
Oslo 6
Norway
Telex: 72640

GREAT BRITAIN
MARANTZ AUDIO U.K. Ltd
Unit 15/16
Saxon Way Industrial Estate
Moor Lane
Harmondsworth UB7 0LW
Great Britain
Telex: 935196

GREECE
SHERTON ELECTRONICS S.A.
P.O. Box 21025
Hippocrates Street 188
Athens 11471
Greece
Telex: 216.795

JAPAN
MARANTZ JAPAN, Inc.
35-1, 7-chome, Sagamiono
Sagamihara-shi, Kanagawa
Japan

KUWAIT
AL ALAMIAH ELECTRONICS
Ussama Building
Fahd al Saleem Street
P.O. Box 23781
Safat-Kuwait
Telex: 22694

ITALY
MARANTZ ITALIANA S.P.A.
Via Chiesa, 74
20126 Milano
Italy

SAUDI ARABIA
AL ALAMIAH ELECTRONICS
P.O. Box 5964
University Street
Riyadh 11432
Saudi Arabia
Telex: 201530

SOUTH AFRICA
MARANTZ
DIVISION OF PHILIPS S.A.
Rainer House
Ove Street, 10
Doomfontein
Johannesburg
Telex: 483.456

SPAIN
PHONO S.A.
Ignacio Iglesias 10
Badafona (Barcelona)
Spain Telex: 59355

SWEDEN
MARANTZ
DIVISION OF PHILIPS
Fo'rsa'ljning AB
Tegetudsva'gen 1
S-115 84 Stockholm
Sweden
Telex: 14060

SWITZERLAND
DYNAXOX ELECTRONICS
Route de Villars 105
1701 Fribourg
Switzerland
Telex: 942377

TURKEY
DOGRUOL Ltd.
I.M.C.
6 Block N°6310
Unkapani
Istanbul
Turkey
Telex: 22085

MALTA
CACHIA & GALEA
Republic Street, 68D
Valetta
Telex: 1682

U.S.A.
MARANTZ COMPANY, Inc.
National Service Department
P.O. Box 577
Chatsworth, CA 91311
U.S.A.

All of the above locations are fully equipped to take care of your total service needs. Because various countries have differing configuration requirements, it is necessary that you contact the service facility in your particular country. In the event that there is no service location listed for your country, please, contact the nearest facility for the necessary assistance.

In case of difficulties, do not hesitate to contact the Technical Department at abovementioned address.

NOTE-FOR U.S.A. ONLY

Parts for your MARANTZ stereo are generally available within 72 hours throughout the nation via a toll-free line to our National Parts Depot in California. The sales professionals who take your call immediately refer to their own desk top computer terminal and can quickly determine the availability and price information you require. If, for some reason, your order should exceed our available stock, we usually can instantly provide an alternate replacement part or current delivery information. When the order is placed and confirmed, the computer simultaneously generates "hard copy" orders at the distribution center. As hard copies come directly from the computer to the national parts depot, your requested stock is assembled and prepared for shipment and placed on the first available carrier for delivery to you.

Phone orders will eliminate mail delays, and we encourage the use of this method. If you order by mail, use MARANTZ parts order forms which are available from MARANTZ NATIONAL PARTS DEPARTMENT.

marantz®

TABLE OF CONTENTS

SECTION	PAGE
1. SHOCK, FIRE HAZARD SERVICE TEST	1
2. P.W. BOARDS	1
3. TEST EQUIPMENT REQUIRED FOR SERVICING	2
4. ADJUSTMENT PROCEDURE	2
5. BLOCK DIAGRAM	3
6. COMPONENT LOCATIONS	4
6.1 Main Amp/Power Supply Assembly (P701) Component Locations	4
6.2 Selector/Phono Amp Assembly (PV01) Component Location	4
6.3 Front Switch Assembly (PS01) Component Locations	5
6.4 LED Display Assembly (PY01) Component Locations	5
6.5 Tone Control TR Assembly (PE01) Component Locations	5
6.6 Master Volume Assembly (PG01) Component Locations	5
6.7 Power Switch Assembly (P901) Component Locations	5
6.8 Tone Defeat Switch Assembly (PE51) Component Locations	5
6.9 Headphone Assembly (PW01) Component Locations	5
6.10 Balance Volume Assembly (PG51) Component Locations	5
7. EXPLODED VIEW AND PARTS LIST	6
8. ELECTRICAL PARTS LIST	9
9. TECHNICAL SPECIFICATIONS	12
10. SCHEMATIC DIAGRAM	14

How to use this service manual

- The "Common parts" which Marantz Japan, Inc. has established are eliminated from this service manual.
- These "Common parts" are applied to all models in the service manuals arranged and issued by MJI.
- To indicate clearly the common parts in the schematic diagram, a line is drawn above or under the Ref. Desig. No. of applicable parts.
- "Common parts" can be supplied from the Marantz service center as ever.
In case of ordering, please establish the parts number of 10 figures following the procedure mentioned in this service manual "How to establish the parts number for common parts".

(NOTE)

When you order parts to the Marantz parts center, please take notice of the following points.

- 1) Please correctly write the parts number of 10 figures following the rule.
- 2) Since ordering parts by the Ref. Desig. No. or ratings indicated in the schematic diagram does not satisfy the above conditions, the Marantz parts supply system does not work properly.
As this case is apt to cause a trouble, please pay attention to it.

MODEL PM-25 STEREO AMPLIFIER

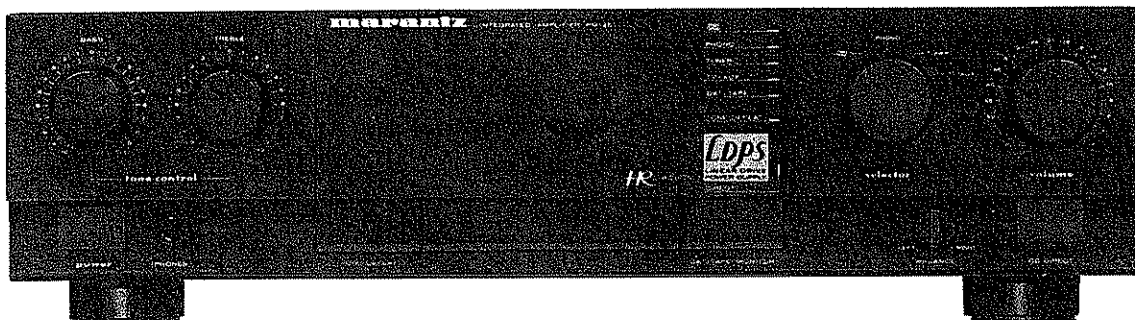

1. SHOCK, FIRE HAZARD SERVICE TEST

CAUTION: After servicing this appliance and prior to returning to customer, measure the resistance between either primary AC cord connector pins (with unit NOT connected to AC mains and its Power switch ON), and the face or Front Panel of product and controls and chassis bottom.

Any resistance measurement less than 1 Megohms should cause unit to be repaired or corrected before AC power is applied, and verified before return to user/customer.

Ref. UL Standard No. 1270. Para. 66.3. D (Mandatory Test after servicing Electrical Appliances, effective 7-1-83).

2. P.W. BOARDS

As can be seen from the circuit diagram the chassis of Model PM-25 consists of the following units. Each unit mounted on a printed circuit board is described within the square enclosed by a bold dotted line on the circuit diagram.

1. Tone Control mounted on P.W. Board PE01
2. Tone Defeat Switch mounted on P.W. Board PE51
3. Master Volume mounted on P.W. Board PG01
4. Balance Volume mounted on P.W. Board PG51
5. Front Switch mounted on P.W. Board PS01
6. Selector/Phone
Amp mounted on P.W. Board PV01
7. Headphone mounted on P.W. Board PW01
8. LED Display mounted on P.W. Board PY01
9. Main Amp/Power
Supply mounted on P.W. Board P701
10. Power Switch mounted on P.W. Board P901

3. TEST EQUIPMENT REQUIRED FOR SERVICING

This table lists the test equipment required for servicing the Model PM-25 Stereo Amplifier.

Item	Use
Distortion Analyzer	Distortion measurements
Audio Oscillator	Sinewave and squarewave signal source
ACVTVM	Voltage measurements (AC)
Oscilloscope	Waveform analysis and trouble shooting and ASO alignment
Circuit Tester	Trouble shooting
DCVTVM	Voltage measurements (DC)
AC Wattmeter	Monitors primary power to amplifier
Line Voltmeter	Monitors potential of primary power to amplifier
Variable Autotransformer (0 to 140V AC, 10A)	Adjust level of primary power to amplifier
Shorting Plug	Shorts amplifier input to eliminate noise pickup

4. ADJUSTMENT PROCEDURE

Main Idling Adjustment

1. Parts for Adjustment

L CH R719 (2.2 k Ω)
R CH R720 (2.2 k Ω)

2. Test Points

L CH J705 (+), J707 (-)
R CH J706 (+), J708 (-)

3. Adjustment Procedure

- (1) Connect a DC digital voltmeter to the test points.
(Minimum volume, no load, stable power source voltage)
- (2) Adjust so that the voltage is 2.3 mV 30 seconds after the power is turned on and 2.5 mV 60 seconds after the power is turned on.
The idling current at this time is 11.5 mA, 12.5 mA.
When stable, the current is of approximately 26 mA (4.5 mV)

* For sets heated up for repairs, etc., let sit with no signal for about 10 minutes before performing the idling adjustment.

5. BLOCK DIAGRAM

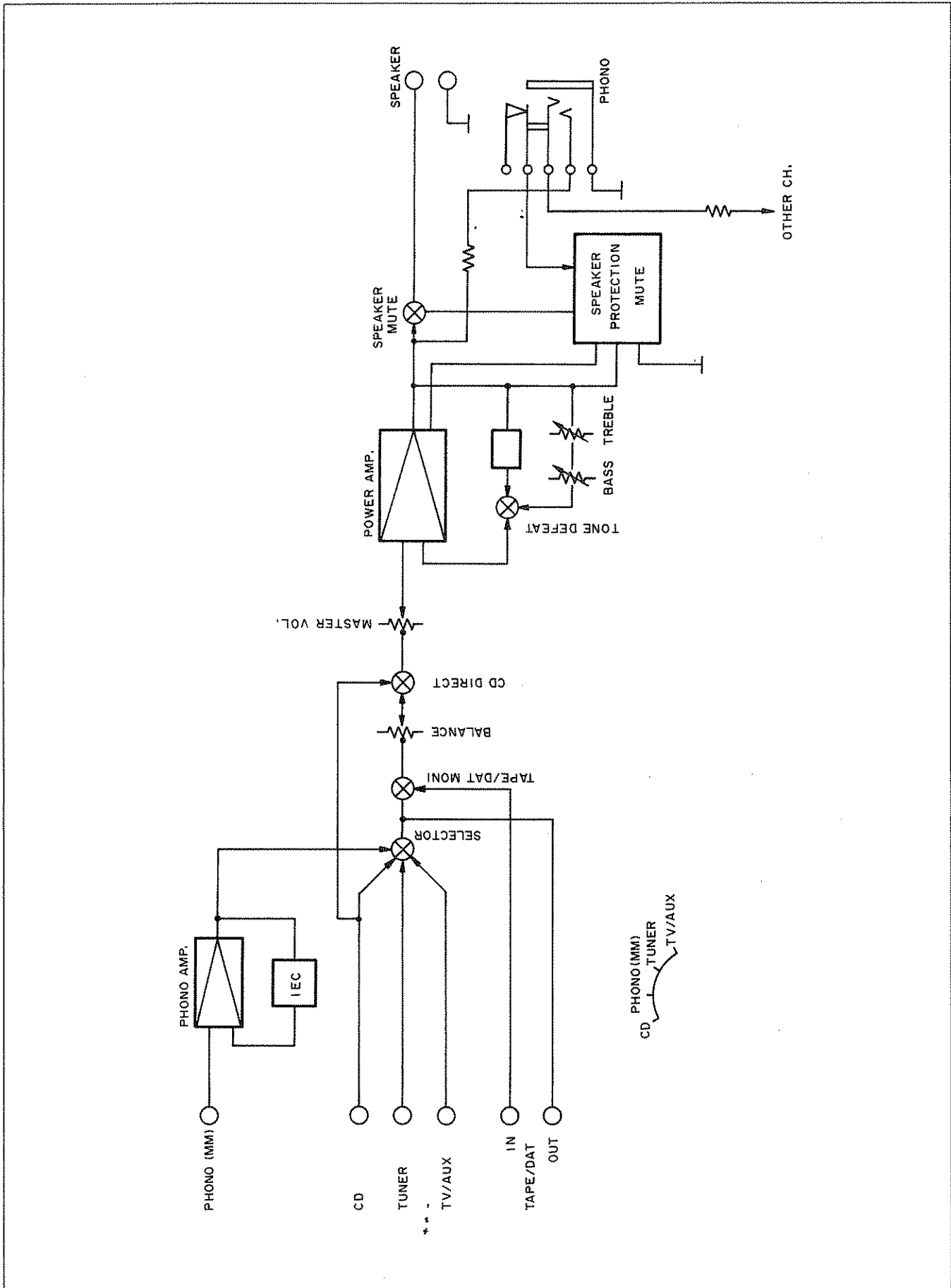

6.3 Front Switch Assembly (PS01) Component Locations

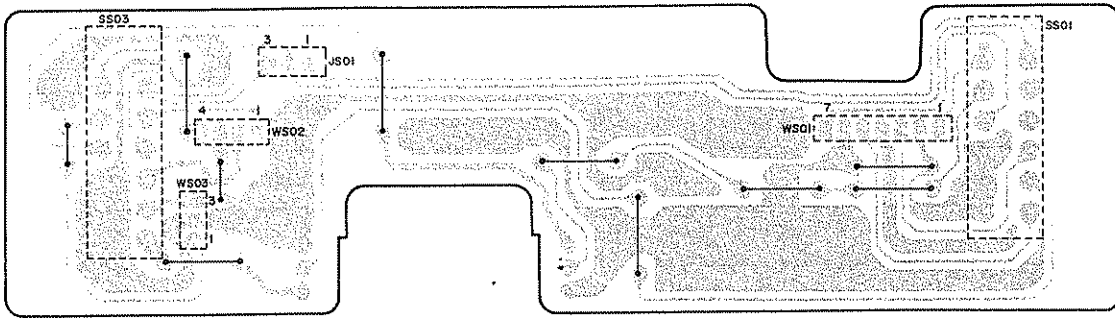

6.4 LED Display Assembly (PY01) Component Locations

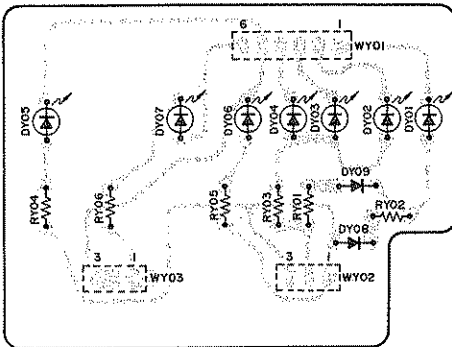

6.5 Tone Control TR Assembly (PE01) Component Locations

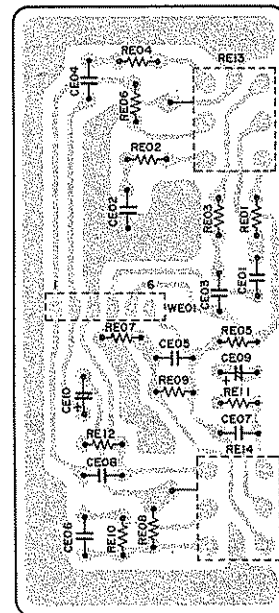

6.6 Master Volume Assembly (PG01) Component Locations

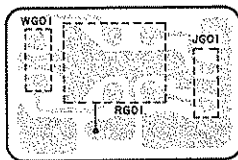

6.7 Power Switch Assembly (P901) Component Locations

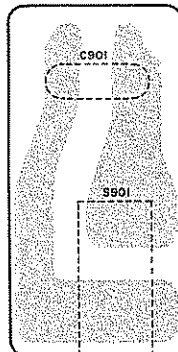

6.8 Tone Defeat Switch Assembly (PE51) Component Locations

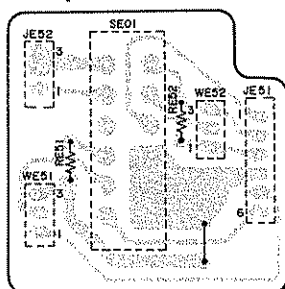

6.9 Headphone Assembly (PW01) Component Locations

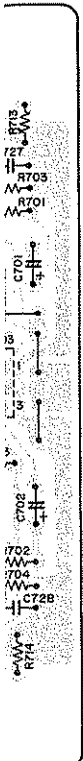
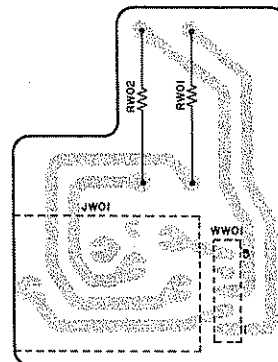

7. EXPLODED VIEW AND PARTS LIST

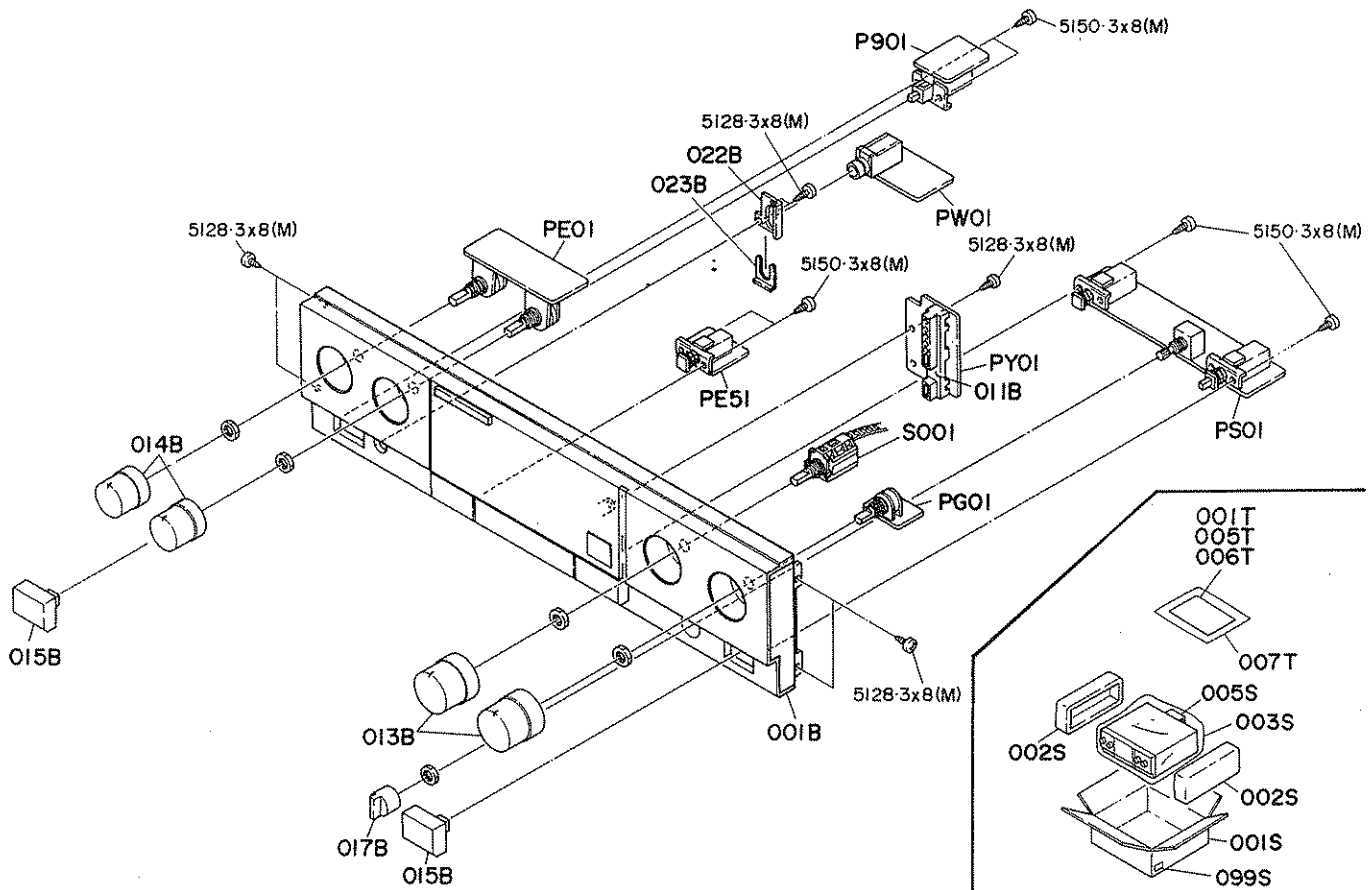

REF. DESIG.	PART NO.	DESCRIPTION
001B	016J248530	Front Panel Assembly
011B	366H274010	Reflector, LED
013B	175H154010	Knob, Volume/Selector
014B	175H154030	Knob, Tone Control
015B	242H270110	Button, Power/CD Direct
017B	263H154130	Knob, Balance
022B	016J104010	Retainer, Headphone Jack
023B	198T114010	Stopper, Headphone Jack
S001	SR00040210	Rotary Switch, Selector

REF. DESIG.	PART NO.	DESCRIPTION
001S	016J801030	PACKING Packing Case
002S	366H809010	Cushion
003S	9014325300	Polyethylene Bag
005S	2864804010	Sleeve
991S	9510901220	Label, Serial No.
001T	016J851210	User Manual
005T	103H854010	Warranty Card
006T	180T854010	Warranty Card
007T	9012540010	Polyethylene Bag

REF. DESIG.	PART NO.	DESCRIPTION
001D	366H257010	Lid, Top Cover
002D	51260408M0	B.T. Screw B4 x 8
002G	366H105010	Chassis, Main
007G	331H160020	Bracket, Phone P.W. Board
009G	176H057040	Leg
010G	51260408M0	B.T. Screw B4 x 8
015G	016J160010	Bracket, Main Amp P.W. Board
019G	2886005020	Clamper
035G	1455259090	Bushing, AC Power Cord
037G	117H861020	Label
901G	016J250040	Rear Panel
001F	262H267010	Heatsink (Q701)
002F	262H267010	Heatsink (Q702)
004F	366H267030	Heatsink (D801)
001K	2259109040	Shield
001L	016J267010	Heatsink, Main
002L	51260312M0	B.T. Screw B3 x 12
022L	51260312M0	B.T. Screw B3 x 12

REF. DESIG.	PART NO.	DESCRIPTION
Δ F001	FS10200500	Fuse 2A 250V
Δ J001	YJ08000300	Jack, Fuse Holder
Δ J021	YJ04001180	Jack, AC Outlet (3P)
J053	YL03010280	Terminal, GND
Δ L001	TS16652030	Power Transformer
Δ W001	YC02000380	A.C. Power Cord

8. ELECTRICAL PARTS LIST

ASSIGNMENT OF COMMON PARTS CODES.

RESISTOR

- R*****: (1) GD05 --- 140, Carbon film fixed resistor, $\pm 5\%$, 1/4W
R***: (2) GD05 --- 160, Carbon film fixed resistor, $\pm 5\%$, 1/6W

① — Resistance value

Examples

① Resistance value

0.1 Ω ...001	10 Ω ...100	1k Ω ...102	100k Ω ...104
0.5 Ω ...005	18 Ω ...180	2.7k Ω ...272	680k Ω ...684
1 Ω ...010	100 Ω ...101	10k Ω ...103	1Mk Ω ...105
6.8 Ω ...068	390 Ω ...391	22k Ω ...223	4.7Mk Ω ...475

(Note) Please distinguish 1/4W from 1/6W by the shape of parts used actually.

C***: CERAMIC CAP.

- (1) DD1 --- 370, Ceramic condenser
 Disc type
 Temp. coeff. P350 ~ N1000, 50V
- ① ②
- Capacity value
 Tolerance

Examples

- ① Tolerance (Capacity deviation)
- $\pm 0.25\text{pF} \dots 0$
 - $\pm 0.5\text{pF} \dots 1$
 - $\pm 5\% \dots 5$

* Tolerance of COMMON PARTS handled here are as follows:

- 0.5pF ~ 5pF... $\pm 0.25\text{pF}$
 - 6pF ~ 10pF... $\pm 0.5\text{pF}$
 - 12pF ~ 560pF... $\pm 5\%$
- ② Capacity value
- | | | |
|-------------|------------|-------------|
| 0.5pF...005 | 3pF...030 | 100pF...101 |
| 1pF...010 | 10pF...100 | 220pF...221 |
| 1.5pF...015 | 47pF...470 | 560pF...561 |

C***: CERAMIC CAP.

- (1) DK16 --- 300, High dielectric constant ceramic condenser
 Disc type
 Temp. chara. 2B4, 50V
- ①
- Capacity value

Example

- ② Capacity value
- | | | |
|-------------|--------------|---------------|
| 100pF...101 | 1000pF...102 | 10000pF...103 |
| 470pF...471 | 2200pF...222 | |

C***: ELECTROLY CAP. (\neq), FILM CAP. (\neq)

- (1) EA --- 10, Electrolytic condenser
 One-way lead type, Tolerance $\pm 20\%$
- ① ②
- Dielectric strength
 Capacity value

Examples

- ① Capacity value
- | | | |
|---------------------------|--------------------------|---------------------------|
| 0.1 μF ...104 | 4.7 μF ...475 | 100 μF ...107 |
| 0.33 μF ...334 | 10 μF ...106 | 330 μF ...337 |
| 1 μF ...105 | 22 μF ...226 | 1100 μF ...108 |
| | | 2200 μF ...228 |
- ② Working voltage
- | | |
|------------|-----------|
| 6.3V...006 | 25V...025 |
| 10V...010 | 35V...035 |
| 16V...016 | 50V...050 |

- (2) DF15 --- 350, Plastic film condenser
 One-way type, Mylar $\pm 5\%$ 50V
- ①
- Capacity value

Examples

- ① Capacity value
- | | |
|-------------------------------------|---------------------------|
| 0.001 μF (1000pF) ...102 | 0.1 μF ...104 |
| 0.0018 μF ...182 | 0.56 μF ...564 |
| 0.01 μF ...103 | 1 μF ...105 |
| 0.015 μF ...153 | |

REF. DESIG.	PART NO.	DESCRIPTION
PE01	YK016J1060	PE01-TONE CONTROL CIRCUIT BOARD P.W. Board, Tone Control
CE01	OF15563010	PE01-CAPACITORS Film 0.056 μF $\pm 5\%$
CE02	OF15563010	Film 0.056 μF $\pm 5\%$
CE03	OF15682010	Film 6800pF $\pm 5\%$
CE04	OF15682010	Film 6800pF $\pm 5\%$
CE07	OF15563010	Film 0.056 μF $\pm 5\%$
CE08	OF15563010	Film 0.056 μF $\pm 5\%$
CE09	OA10601620	Elect 10 μF 16V
CE10	OA10601620	Elect 10 μF 16V
RE13	RM05031290	PE01-RESISTORS 50K Ω (C), Variable
RE14	RM05031290	50K Ω (C), Variable
WE01	YU06140260	PE01-MISCELLANEOUS Jumper Lead, 6P
PE51	YK016J1070	PE51-TONE DEFEAT SWITCH CIRCUIT BOARD P.W. Board, Tone Defeat Switch
JE51	YJ06002450	Jack, 6P
JE52	YJ07001080	Jack, 3P
SE51	SP04010580	Push Switch
WE51	YU03120260	Jumper Lead, 3P
WE52	YU03180260	Jumper Lead, 3P
PG01	YK016J1050	PG01-MASTER VOLUME CIRCUIT BOARD P.W. Board, Master Volume
RG01	RM01041100	Variable Resistor, 100K Ω (D)
JG01	YJ06002430	Jack, 3P
WG01	YU03240760	Jumper Lead, 3P
PS01	YK016J1030	PS01-FRONT SWITCH CIRCUIT BOARD P.W. Board, Front Switch
RG51	RM01041070	Variable Resistor, 100K Ω (MN), Balance
JS01	YJ06002430	Jack, 3P
SS01	SP04010560	Push Switch, Tape Monitor
SS03	SP04010570	Push Switch, CD/Phono Direct
WS01	YU07140260	Jumper Lead, 7P
WS02	YU04120260	Jumper Lead, 4P
WS03	YU03100260	Jumper Lead, 3P

REF. DESIG.	PART NO.	DESCRIPTION
PV01	YK016J1010	PV01-SELECTOR/PHONO AMP CIRCUIT BOARD P.W. Board, Selector/Phono Amp
		PV01-CAPACITORS
CV01	OA10405020	Elect 0.1 μ F 50V
CV02	DK18103310	Ceramic 0.01 μ F +80% -20%
CV03	DK18103310	Ceramic 0.01 μ F +80% -20%
CV04	DK18103310	Ceramic 0.01 μ F +80% -20%
C401	DF55151090	Film 150pF \pm 5%
C402	DF55151090	Film 150pF \pm 5%
C403	OA10601620	Elect 10 μ F 16V
C404	OA10601620	Elect 10 μ F 16V
C405	OA22701020	Elect 220 μ F 10V
C406	OA22701020	Elect 220 μ F 10V
C407	OF15473010	Film 0.047 μ F \pm 5%
C408	OF15473010	Film 0.047 μ F \pm 5%
C409	OF15123010	Film 0.012 μ F \pm 5%
C410	OF15123010	Film 0.012 μ F \pm 5%
C411	OA22601620	Elect 22 μ F 16V
C412	OA22601620	Elect 22 μ F 16V
C413	OF15392010	Film 3900pF \pm 5%
C414	OF15392010	Film 3900pF \pm 5%
C415	OA10701620	Elect 100 μ F 16V
C416	OA10701620	Elect 100 μ F 16V
C417	OF15102010	Film 1000pF \pm 5%
C418	OF15102010	Film 1000pF \pm 5%
C419	DK18103310	Ceramic 0.01 μ F +80% -20%
		PV01-RESISTORS
Δ R417	NF02470140	47 Ω \pm 5% $\frac{1}{4}$ W, Fuse
Δ R418	NF02470140	47 Ω \pm 5% $\frac{1}{4}$ W, Fuse
		PV01-SEMICONDUCTORS
Q401	HC10053090	IC NJM2068-DD
		PV01-MISCELLANEOUS
JV01	YT02020720	Terminal, RCA (2P)
JV02	YT02040730	Terminal, RCA (4P)
JV03	YT02040730	Terminal, RCA (4P)
JV04	YJ06002450	Jack, 6P
JV05	YJ06002460	Jack, 7P
JV06	YJ06002440	Jack, 4P
JV07	YJ06002440	Jack, 4P
JV08	YL01010130	Terminal, Earth Lug
J401	YT02020720	Terminal, RCA (2P)
L401	LC13240010	Choke Coil 320 μ H
L402	LC13240010	Choke Coil 320 μ H
SV01	SS04040080	Slide Switch, Input Selector

REF. DESIG.	PART NO.	DESCRIPTION
PW01	YK016J1090	PW01-HEADPHONE CIRCUIT BOARD P.W. Board, Headphone
RW01	GA05331020	Resistor 330 Ω \pm 5% 2W
RW02	GA05331020	Resistor 330 Ω \pm 5% 2W
JW01	YJ01002520	Jack, Headphone
WW01	YU05380260	Jumper Lead, 5P
		PY01-LED DISPLAY CIRCUIT BOARD P.W. Board, LED Display
PY01	YK016J1080	
DY01	HI10062320	L.E.D. LT3D8B
DY07	HD20002000	Diode 1SS133, etc.
DY08	HD20002000	Diode 1SS133, etc.
DY09	HD20002000	Diode 1SS133, etc.
WH01	YU06160260	Jumper Lead, 6P
WY02	YU03200260	Jumper Lead, 3P
WY03	YU03220260	Jumper Lead, 3P
		P701-MAIN AMP/POWER SUPPLY CIRCUIT BOARD P.W. Board, Main Amp/Power Supply
P701	YK016J1020	
		P701-CAPACITORS
CN01	OA47505020	Elect 4.7 μ F 50V
CN02	OA47601020	Elect 47 μ F 10V
CN03	DK18103310	Ceramic 0.01 μ F +80% -20%
CN04	OA22601620	Elect 22 μ F 16V
C701	OA22601620	Elect 22 μ F 16V
C702	OA22601620	Elect 22 μ F 16V
C705	OA22605020	Elect 22 μ F 50V
C706	OA22605020	Elect 22 μ F 50V
C707	OA47605020	Elect 47 μ F 50V
C708	OA47605020	Elect 47 μ F 50V
C709	OA47705020	Elect 470 μ F 50V
C710	OA47705020	Elect 470 μ F 50V
C711	DF56150090	Film 15pF \pm 10%
C712	DF56150090	Film 15pF \pm 10%
C713	DF56100090	Film 10pF \pm 10%
C714	DF56100090	Film 10pF \pm 10%
C715	OA10701020	Elect 100 μ F 10V
C716	OA10701020	Elect 100 μ F 10V
C723	OA47605020	Elect 47 μ F 50V
C724	OA47605020	Elect 47 μ F 50V
C727	DF55181090	Film 180pF \pm 5%
C728	DF55181090	Film 180pF \pm 5%
C801	DK18103310	Ceramic 0.01 μ F +80% -20%
C802	DK18103310	Ceramic 0.01 μ F +80% -20%
C803	OA47405020	Elect 0.47 μ F 50V
C804	EB47804520	Elect 4700 μ F 45V
C805	OA22703520	Elect 220 μ F 35V
C806	OA10701620	Elect 100 μ F 16V
C807	EB47804520	Elect 4700 μ F 45V
C808	OA22702520	Elect 220 μ F 25V
C809	OA10701020	Elect 100 μ F 10V

REF. DESIG.	PART NO.	DESCRIPTION
P701-RESISTORS		
RN01	GG05102160	1K Ω \pm 5% 1/6W
RN02	GG05102160	1K Ω \pm 5% 1/6W
R719	RA04720780	4.7K Ω , Trimming
R720	RA04720780	4.7K Ω , Trimming
Δ R727	GG05022160	2.2 Ω \pm 5% 1/6W
Δ R728	GG05022160	2.2 Ω \pm 5% 1/6W
Δ R729	GG05022160	2.2 Ω \pm 5% 1/6W
Δ R730	GG05022160	2.2 Ω \pm 5% 1/6W
Δ R731	GO10102030	0.1 Ω \pm 10% 3W
Δ R732	GO10102030	0.1 Ω \pm 10% 3W
Δ R733	GO10102030	0.1 Ω \pm 10% 3W
Δ R734	GO10102030	0.1 Ω \pm 10% 3W
R735	GA05100020	10 Ω \pm 5% 2W
R736	GA05100020	10 Ω \pm 5% 2W
R737	GG05221160	220 Ω \pm 5% 1/6W
R738	GG05221160	220 Ω \pm 5% 1/6W
R747	GG05220160	22 Ω \pm 5% 1/6W
R748	GG05220160	22 Ω \pm 5% 1/6W
R749	GG05220160	22 Ω \pm 5% 1/6W
R750	GG05220160	22 Ω \pm 5% 1/6W
R801	NF02220140	22 Ω \pm 2% 1/4W, Fuse
R803	NF02101140	100 Ω \pm 2% 1/4W, Fuse
R804	GG05102120	1K Ω \pm 5% 1/2W
R805	NK05102010	1K Ω \pm 5% 1W, Metal
R806	GA05181010	180 Ω \pm 5% 1W
R808	GG05102120	1K Ω \pm 5% 1/2W
R809	NK05221010	220 Ω \pm 5% 1W, Metal
R810	GA05102010	1K Ω \pm 5% 1W
P701-SEMICONDUCTORS		
DN01	HD20014010	Diode 1SS81
DN02	HD20014010	Diode 1SS81
DN03	HD20002000	Diode 1SS133, etc.
Δ D801	HD20008290	Diode S4VB20
D802	HD20029050	Diode S5688G
D803	HD20002000	Diode 1SS133, etc.
Δ D804	HD32401000	Zener 24V
Δ D805	HD31501000	Zener 15V
Δ D806	HD20002000	Diode 1SS133, etc.
Δ D807	HD31601000	Zener 16V
Δ D808	HD30511000	Zener 5.1V
QN01	HT322402A0	Transistor 2SC2240(GR, BL)
QN02	HT322402A0	Transistor 2SC2240(GR, BL)
QN03	HT109702A0	Transistor 2SA970(GR, BL)
QN04	HC10042050	IC TA7317P
Q701	HC10114060	IC μ PC1270H
Q702	HC10114060	IC μ PC1270H
Q703	HT334191Y0	Transistor 2SC3419(Y)
Q704	HT334191Y0	Transistor 2SC3419(Y)
Δ Q709	HT342672A0	Transistor 2SC4267(V, U)
Δ Q710	HT342672A0	Transistor 2SC4267(V, U)
Δ Q711	HT116312A0	Transistor 2SA1631(V, U)
Δ Q712	HT116312A0	Transistor 2SA1631(V, U)
Q801	HT420372A0	Transistor 2SD2037
Q802	HT213572A0	Transistor 2SB1357

REF. DESIG.	PART NO.	DESCRIPTION
P701-MISCELLANEOUS		
J701	YJ06002430	Jack, 3P
J702	YJ06002430	Jack, 3P
J703	YJ06002430	Jack, 3P
J704	YT01040330	Terminal, Speaker
J705	YJ06002390	Jack, 5P
J801	YP06001040	Plug, 3P
Δ LN01	LY20240260	Relay
L701	LL23905120	Coil
L702	LL23905120	Coil
W701	YU04560260	Jumper Lead, 4P
P901-POWER SWITCH CIRCUIT BOARD		
P901	YK016J10A0	P.W. Board, Power Switch
Δ C901	DK17103840	Ceramic Cap. 0.01 μ F \pm 20% 40V
Δ S901	SP01011120	Push Switch, Power

(W01-99)	Assembly and Wiring
(T01-99)	Adjustment
(X01-00)	Correction

NOTE ON SAFETY:

Symbol Δ Fire or electrical shock hazard. Only original parts should be used to replace any part marked with symbol Δ . Any other component substitution (other than original type), may increase risk of fire or electrical shock hazard.

9. TECHNICAL SPECIFICATIONS

AMPLIFIER SECTION

Power Output per Channel	
FTC 8 ohms (40 Hz – 20 kHz)	30 watts
Total Harmonic Distortion at Rated Power	
8 ohms	0.1%
I.M. Distortion at Rated Power (SMPTE)	
8 ohms	0.03%
Damping Factor	200

MM CARTRIDGE INPUT

Frequency Response (RIAA)	±0.5 dB
Signal-to-Noise Ratio (A weighted)	83 dB
Phono Input Overload (1kHz)	150 mV
Input Impedance	47 k Ω
Input Capacitance	150 pF
Input Sensitivity	2.5 mV

CD, AUX. INPUT

Input Impedance	45 k Ω
Input Sensitivity	150 mV
Frequency Response (± 1 dB)	10 Hz – 50 kHz
Signal-to-Noise Ratio (A weighted)	86 dB

OUTPUT VOLTAGE

Tape Out [PHONO (MM) 5.0 mV 1 kHz Input]	290 mV
--	--------

OUTPUT IMPEDANCE

Tape Out (at Phono Position)	220 Ω
------------------------------	--------------

GENERAL

Power Requirements	120 V AC, 60 Hz
Power Consumption at Rated Output, both Channels Operating at 8 Ω	135 watts
Dimensions (includes feet and knobs):	
Panel Width	16-1/2 inches (420 mm)
Panel Height	4-5/8 inches (118 mm)
Depth	11-1/2 inches (292 mm)
Weight	
Unit Alone	11.7 lb. (5.3 kg)

Model PM-25

- 0701, Q702 HD20008290
µPC-1270H
- 0703, Q704 HD20029050
25C3419
- Q705, Q710 DY08, DY09, Q701-0704
25C2240(GR, BL) 25C970(GR, BL)
193139 B1C.
- Q711, Q712 HT328672A0
25A1631
- Q801 HT420372A0
25D2037
- Q802 HT213572A0
25B1357
- Q803 QN01, QN02
HT322402A0
25C2240 (GR, BL)
- Q804 HT109702A0
25A970(6R, RL)
- Q805 QY01- QY04,
QY05, QY07
HT10062320
LED (RED)
- Q806 QY05
HT10063320
LED (GR)
- D801 HD20008290
S4VB20
- D802 HD20029050
S56886
- D803 D806, D803
DY08, DY09, Q701-0704
25C2240(GR, BL) 25C970(GR, BL)
193139 B1C.
- D804 HD32401000
24V ZENER
- D805 HD31501000
15V ZENER
- D807 HT213572A0
15V ZENER
- D808 HD30511000
5.1V ZENER
- Q801 QN01, QN02
HT322402A0
25C2240 (GR, BL)
- Q802 HT109702A0
25A970(6R, RL)
- Q803 QY01- QY04,
QY05, QY07
HT10062320
LED (RED)
- Q804 QY05
HT10063320
LED (GR)

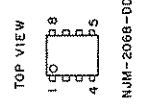
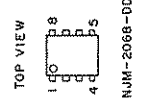
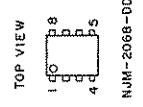
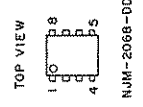
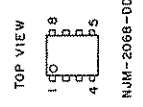
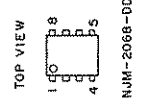
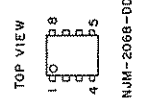
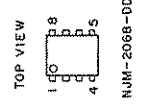
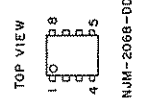
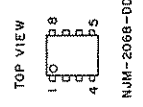
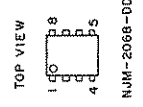
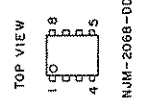
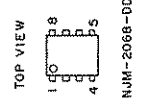
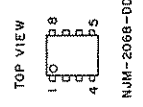
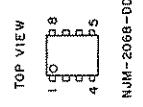
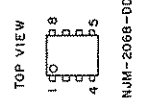
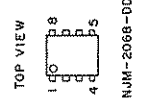
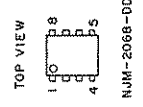
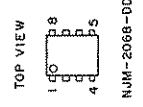
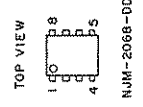
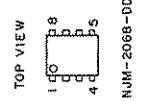
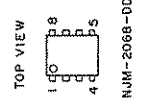
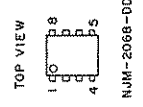
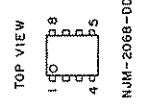
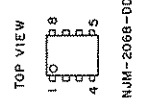
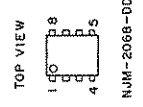
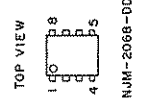
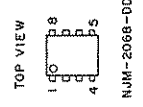
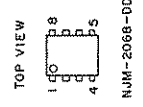
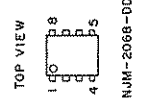
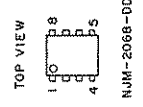
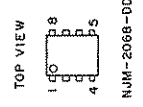
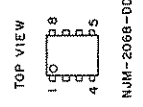
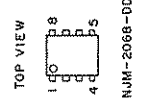
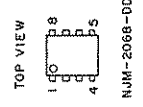
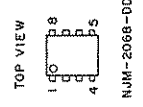
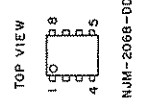
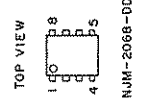
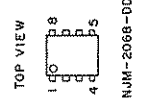
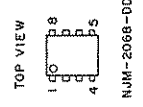
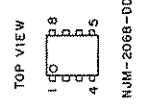
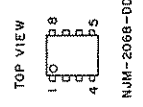
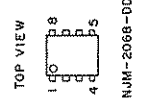
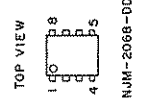
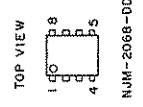
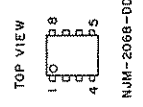
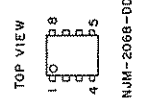
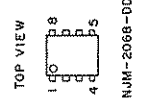
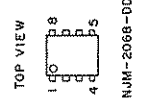
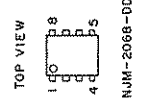
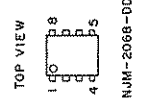
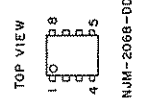
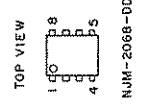
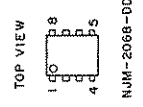
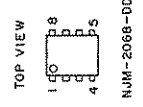
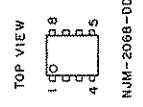
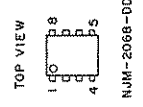
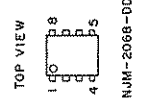
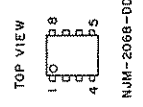
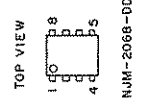
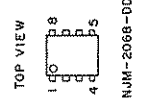
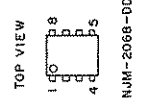
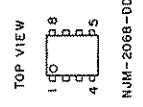
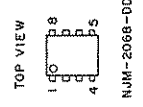
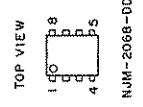
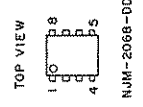
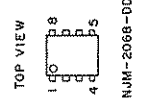
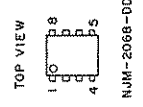
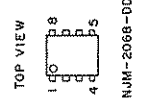
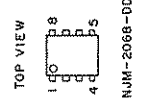
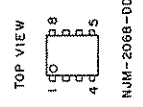
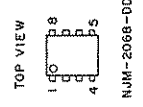
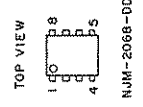
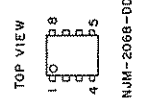
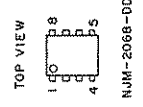
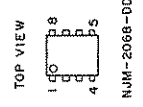
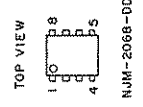
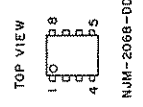
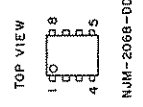
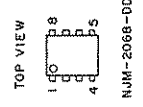
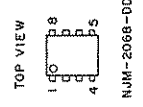
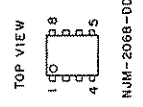
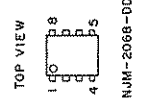
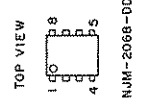
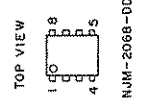
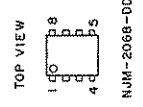
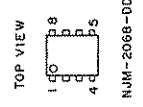
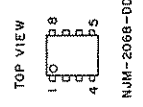
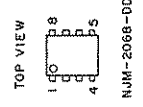
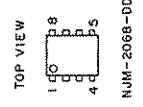
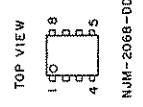
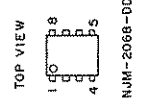
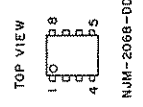
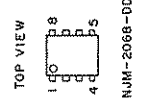
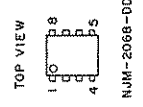
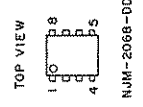
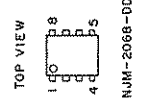
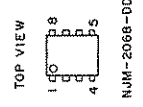
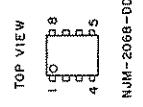
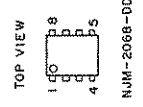
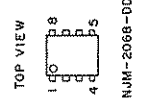
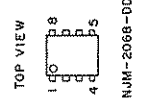
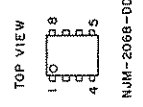
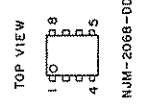
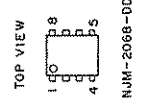
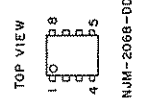
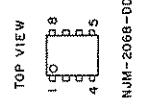
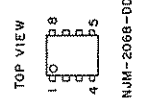
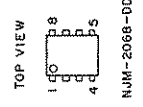
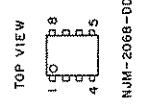
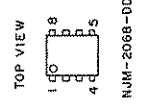
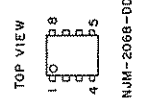
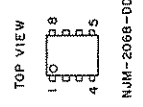
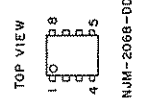
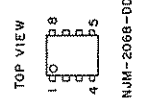
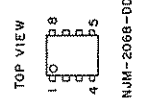
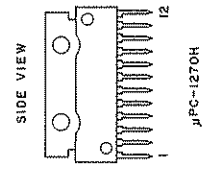
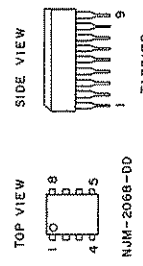
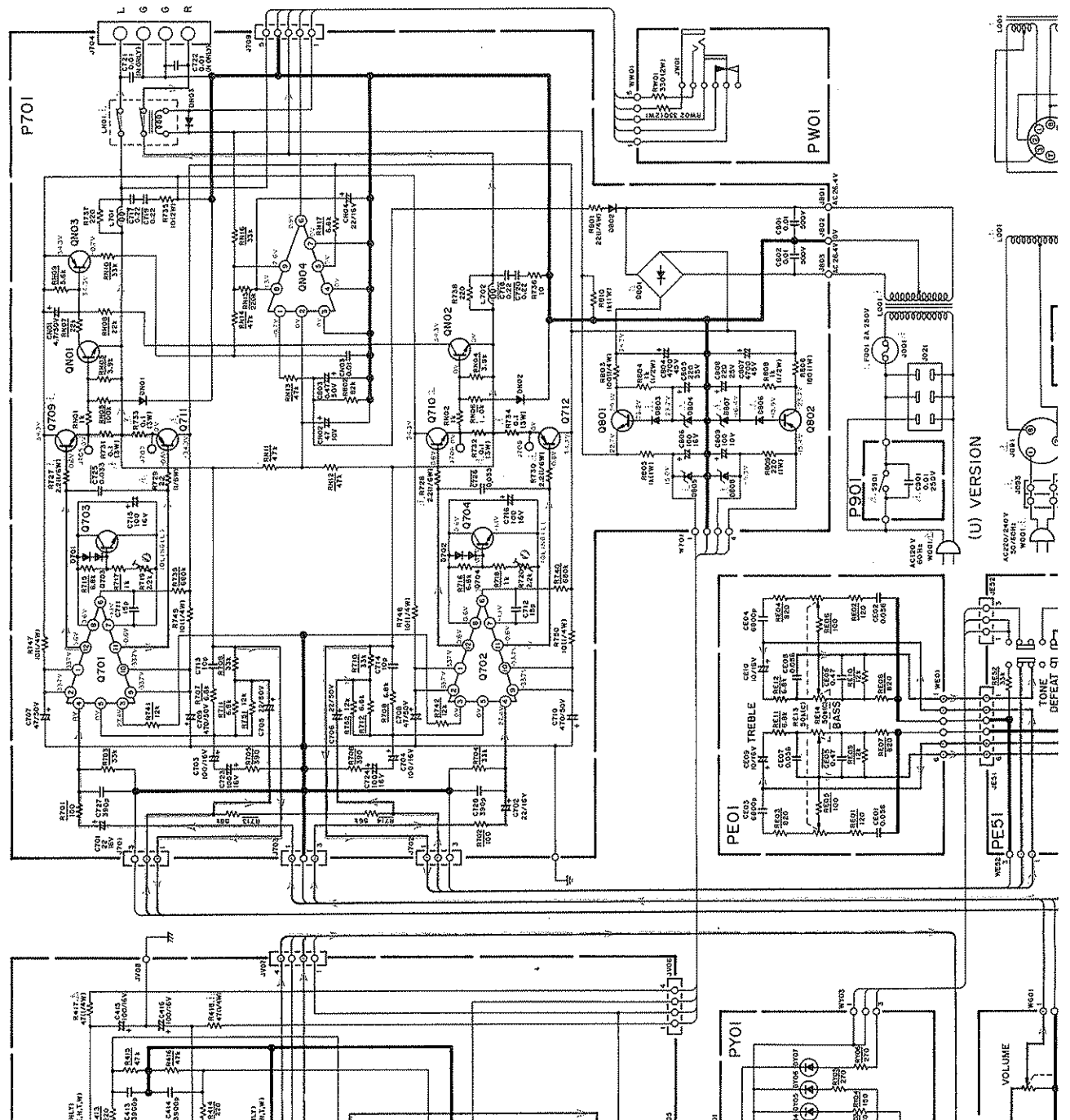

10. SCHEMATIC DIAGRAM

