



Product Information Sheet

DAEXEXT Weatherproof Extreme Exciter 25mm



IP67 approved

Applications

Waterproof, sealed exciter for use in adverse environments such as outdoor environments, bathrooms or any application where standard exciters cannot operate.

Technical Features

- Available in 4, 6, 8, 12, 16, 24 ohms
- Available in light grey & black colours
- Basic exciter dimensions : OD Φ 70mm, Thickness – 18.1mm, Weight – 89gms
- Bonded to the speaker panel via a highly durable 3M adhesive tape with excellent environmental resistance.
- Screw thread mounting attachment for the exciter currently under development
- Passed IP6x (dust-tight) and IPx7 (waterproof) testing at external testing company (TUV)
- Aluminium heatsink allows heat generated by exciter to be dissipated outside the housing
- Acoustic performance is similar to the standard G1 25mm exciter
- Custom watertight cable connectors for connection to the amplifier can be also be supplied

Dynamic Drive Parameters

BI	R_e	$L_e @ 10\text{kHz}$	Expo L_e	Expo R_e	f_{re}	Mms	Mmm
Tm	Ω	μH			kHz	gms	gms
3.984	7.98	0.987	0.832	1	62.2	1.71	75

Cms	Rms	dDrv
m/N	Ns/m	cm
1.24e-5	2.146	2.5

Impedance measured using Clio and drive parameters calculated using ExcParam (NXT Designer software)

Basic Drawing

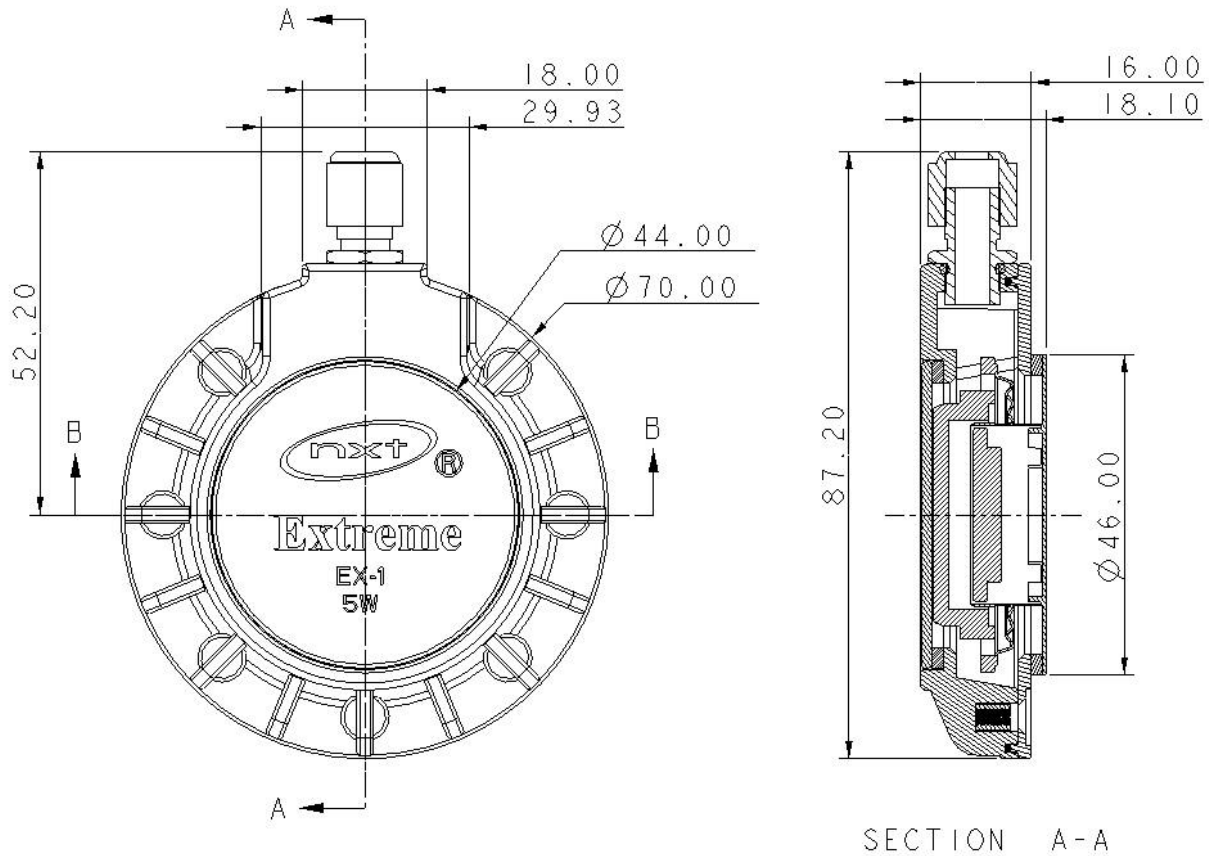

Dayton Audio
 Springboro, Ohio, USA
 Phone: 937.743.8248
 daytonaudio.com